

# Semi-Automatic Engine Valve Cleaning Machine Using Cam and Follower Mechanism

Ayush Chordiya<sup>1</sup>, Aniket Nagrale<sup>2</sup>, Bhargav Pimparkar<sup>3</sup>, Richa Kubal<sup>4</sup>, Jayashri Chopade<sup>5</sup>

<sup>1,2,3,4</sup>Students, Department of mechanical Engineering

<sup>5</sup>Professor, Department of mechanical Engineering

Pimpri Chinchwad College of Engineering and Research, Ravet, Pune, Maharashtra, India

\*\*\*

**Abstract** - A significant portion of the automotive industry and a significant source of revenue for businesses is automotive maintenance. The valve lapping method covered in this thesis is carried out during the internal combustion engine maintenance, which is currently regarded as a crucial component of automobile maintenance. The existing techniques for valve lapping employed by the majority of auto repair shops are inefficient and take up a lot of time. By reducing the need for human intervention, the "Valve lapping Machine for Internal Combustion Engines" machine is intended to solve these issues.

As the abrasive goes back and forth between the two surfaces and removes material from both, minute conchoidal fractures are created. According to observations, if valves are not lapped, some of the energy from the consumed gases will be wasted, which will result in the engine not having adequate power. Therefore, since this task is semi-automatic, it is not necessary for the worker to have previous knowledge in order to use this equipment to clean four-stroke valves. The major objective of this project is to develop a machine that is more effective and efficient than currently utilised techniques for valve lapping while also lowering labour costs by minimising the need for human intervention.

**Key Words:** Valve lapping; Engine valves; Cylinder head.

## 1. INTRODUCTION

In order to prevent compression leaks from the combustion chamber through the seating from the process of valve lapping in an internal combustion engine cylinder head and to prevent air/fuel/air mixture leaking into the combustion chamber through the seating, a good seat between the valve seating area of an engine valve and the valve seat area of cylinder head is desired. The internal combustion engine works by establishing a specific compression ratio, which varies from engine to engine, and combusting a compressed air-fuel mixture to a predetermined volume. And if the fuel-air mixture seeps through the seats, the combustion process won't occur because the fuel-air mixture volume will change.

### 1.1 Lapping process

We must occasionally look directly at the valve seat area when the valve is being lapped. It's the typical method of determining if the valve seat is sound or whether more valve

polishing is required. A lapped and an unlapped valve are seen in Figure 2. The most popular method for watching how valves are sitting after valve lapping is one that involves gasoline. After completing the valve job, the mechanic or technician places the precise valve in the precise location in the cylinder head and adds fuel to the valve stem that he must watch. The valve's seating area is then reached by this spilled gasoline.

### 1.2 Engine valves

Exhaust and intake valves are the two different types of engine valves. In a cylinder head, these valves might be easily recognized. Exhaust valves are often smaller than inlet valves. Although there may be multiple inlet valves and exhaust valves for a single cylinder. Both inlet valves and exhaust valves come in a variety of designs. Poppet valves are the type of valve that are used the most frequently. Next, certain turbocharged engines include sodium valves. And under various circumstances, mask valves, mushroom valves, and tulip valves could be seen. A valve is illustrated in great detail in the following figure.

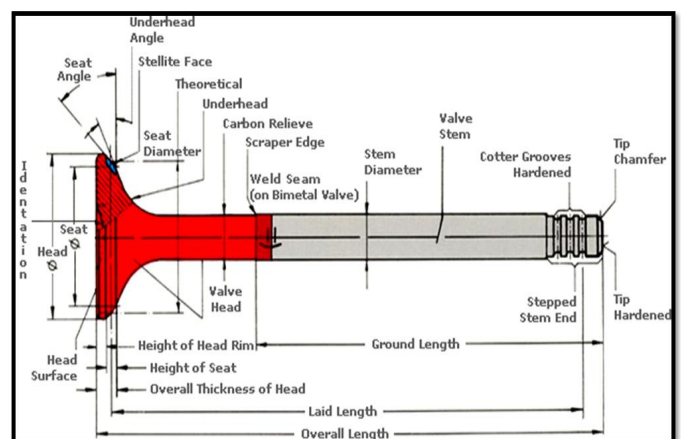

Fig-1: Valve Terminology

### 1.3 Lapping compound

Before beginning, a lapping compound is put to the valve seat. The cylinder block's valve and valve seat are smoothed out by lap compound wear, which also improves the seat. Two different types of compounds are often offered in the top and bottom ends of a lapping compound tube

individually. the two categories denoted as coarse and fine. By looking at the valve seat, the technician determines which sort of compound should be used. Coarse compound is used if the valve seat has jagged edges. Otherwise, a smooth surface is achieved with a fine compound.

### 1.4 Cylinder head

The inlet and exhaust valves and their ports are located in the cylinder head for the intake of the air/fuel combination and the exhaust of the combustion products. The cylinder head is the casting that seals the combustion end of the cylinder block. If an overhead cam shaft is present, the cylinder head also makes rocker arms and valve springs possible

## 2. Plan of Work

- 1) Due to the problem of a friend's car breakdown, We came across the process called as the valve lapping.
- 2) During the servicing of car we identified the problem that valve lapping process is very time consuming, So we brainstormed various ideas about developing a machine that will make this process time efficient so we decided to make this our BE Project.
- 3) We started our work with searching various research papers from various articles and published journals and identified the gap.
- 4) After research and identification of gap we worked on various mechanism and found that cam and follower mechanism is suitable for our project and we finalized.
- 5) Next step was designing the rough 2D model.
- 6) Calculation of standard components were done and after that 3D model of our machine was completed using the CATIA V5 Software.
- 7) After that Analysis of machine components was done using ANSYS Software and parameters such as strength of components and stress on it is calculated.
- 8) Standard components according to machine requirements were selected and manufacturing of machine was completed.
- 9) Finally the testing of Machine was carried out effectively.

## 3. Bill of Materials

Sr no.	Name of components	Dimension required	Quantity	Cost/unit
1	Motor	-	2	1000
2	Coil spring	Dia=2.2mm Pitch=5mm Length=300mm	2	1200
3	Cam & Follower	-	1	1300
4	Hollow square pipe	80*80 mm Thickness=2.5mm	2	1000
5	Metal plate		1	500
6	Metal rods	4(35*35) Height=80mm	4	500
7	Fasteners & miscellaneous		-	500
	<b>Total</b>			6000/-

Table-1

## 4. CAD DESIGN

Using computer systems (or workstations) to help with the creation, revision, analysis, or optimization of a design is known as computer-aided design (CAD). CAD software is used to develop databases for manufacturing, boost designer efficiency, enhance design quality, and improve communications through documentation. Electronic files for printing, machining, or other manufacturing processes are frequently the CAD output. Another word used is CADD.

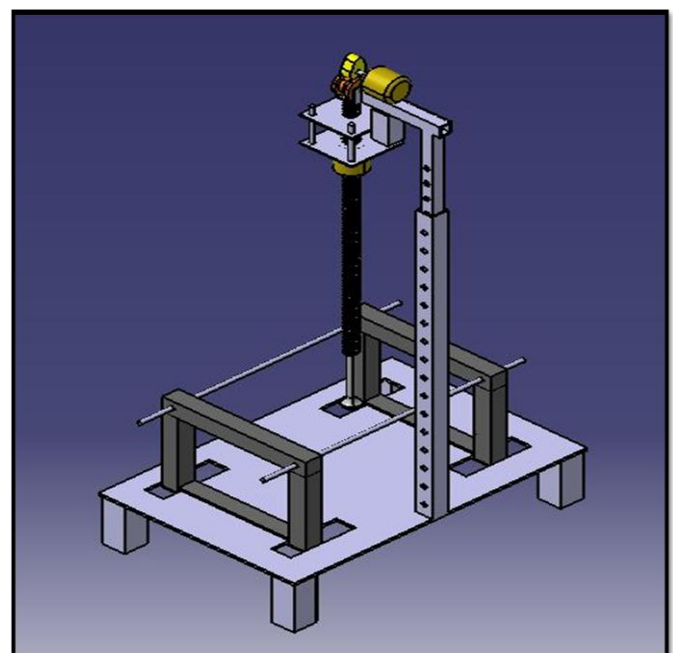

Fig-2: Valve lapping catia

## 5. WORKING OF SEMI AUTOMATIC VALVE CLEANING MACHINE:

The first step is that, we are going to fix the cylinder head on the base plate with the help of frame consisting of Lead screws and make the adjustments according to cylinder head. The height adjustment of telescopic tube is done using nut and bolt by matching the two drilled holes on the inner and outer tubes, according to cylinder head.

The Lapping stick is attached to high stiffness spring using washer. The valve will be attached to the lapping stick with help of suction cup provided on the other end of the stick.

After that the compound paste will be applied on the valve seat and the valve will be inserted in the engine head. Hard abrasive particles are combined with an appropriate base to create lap paste. The basis might be a water-soluble lubricant or an oil-based substance like grease. Commonly used compound pastes/lapping powder are silicon carbide, aluminium oxide, boron carbide, diamond powders, etc.

The battery is used to provide the power to 2 motors [motor-1 (reciprocating movement of cam and follower) and motor-2 (rotation of valve specimen in clockwise and anti-clockwise direction)].

Further the input will be given to the Arduino UNO which is connected to power bank for controlling the motor 2 which is going to rotate valve specimen in the cylinder head in such a way that good seat will be obtained between valve and cylinder head and hence, the cleaning of carbon deposited on the valve seat takes place.

## 6. ANALYSIS OF MACHINE USING ANSYS SOFTWARE.

### 6.1 Mesh

An intelligent, automated, high-performance general-purpose product is ANSYS Meshing. For precise, effective Multiphysics solutions, it generates the best mesh. A single mouse click can create a mesh for every component of a model that is suitable for a certain study. Within the ANSYS Workbench environment, ANSYS Meshing is automatically integrated with each solver.

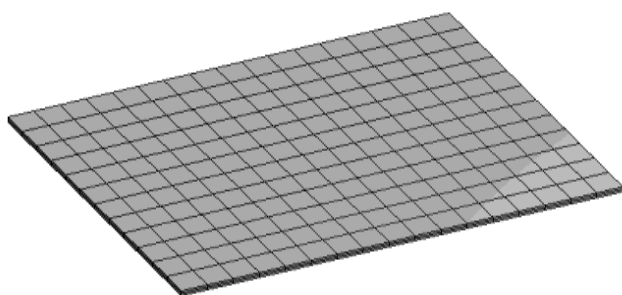

Fig-3: Meshing of base plate

### 6.2 Boundary Condition:

An related load or a known value for a displacement are set as a boundary condition for the model. You can only set the load or displacement for a given node; you cannot set both. Force, pressure, and temperature are the three basic loading types that are offered in FEA. These may be utilised with respect to points, surfaces, edges, nodes, and components, as well as being remotely offset from a feature.

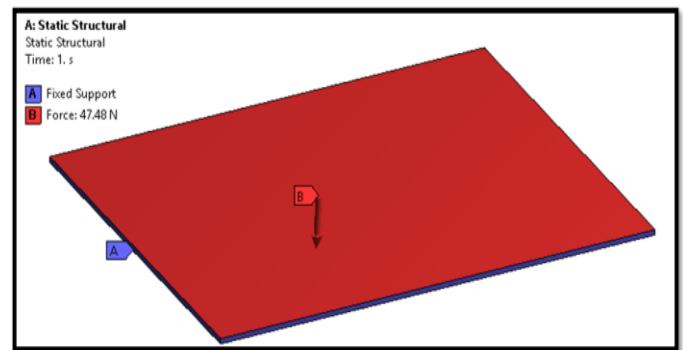

Fig-4: Boundary Condition of Base plate

### 6.3 Total Deformation:

Regardless of the programme being utilised, the phrases "total deformation" and "directed deformation" are general concepts in finite element methods. The displacement of the system in a certain axis or user-defined direction is referred to as directional deformation. The vector sum of each system's directional displacements represents the total deformation.

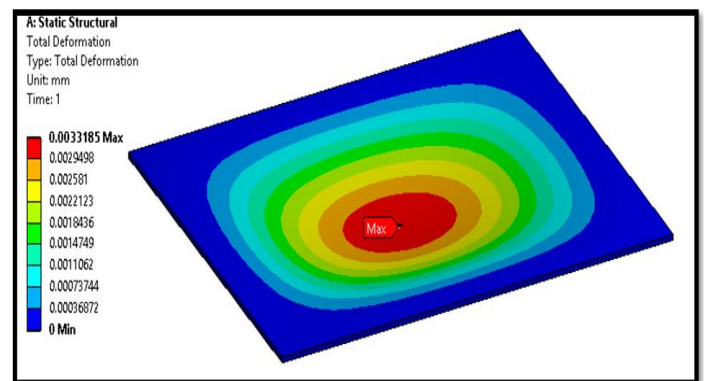

Fig5- Total Deformation of Base plate

### 6.4: Equivalent Stress

The concept of equivalent stress, also known as von Mises stress, is frequently applied in design work because it enables the representation of any arbitrary three-dimensional stress condition as a single positive stress value. The maximum equivalent stress failure theory, which is used to forecast yielding in a ductile material, includes equivalent stress.

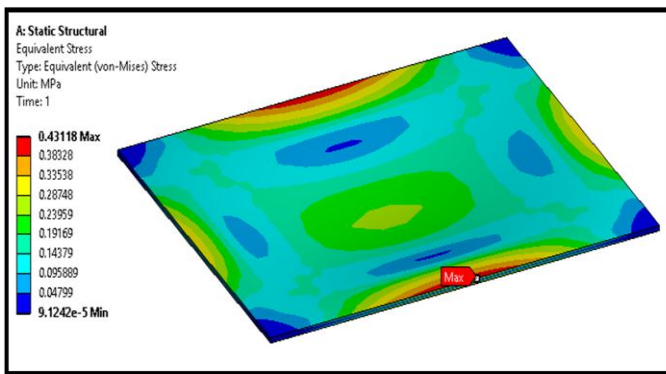

Fig-6 Equivalent Stress on Base plate



Fig- 7 front view of machine

## 7: Geometry of Machine

Properties of Outline Row 3: Structural Steel				
	A	B	C	D
1	Property	Value	Unit	
2	Material Field Variables	Table		
3	Density	7850	kg m <sup>-3</sup>	
4	Isotropic Secant Coefficient of Thermal Expansion			
6	Isotropic Elasticity			
7	Derive from	Young...		
8	Young's Modulus	2E+11	Pa	
9	Poisson's Ratio	0.3		

Table-2 Material properties of geometry of machine

## 8: Results and Plots:

### 8.1 Total Deformation

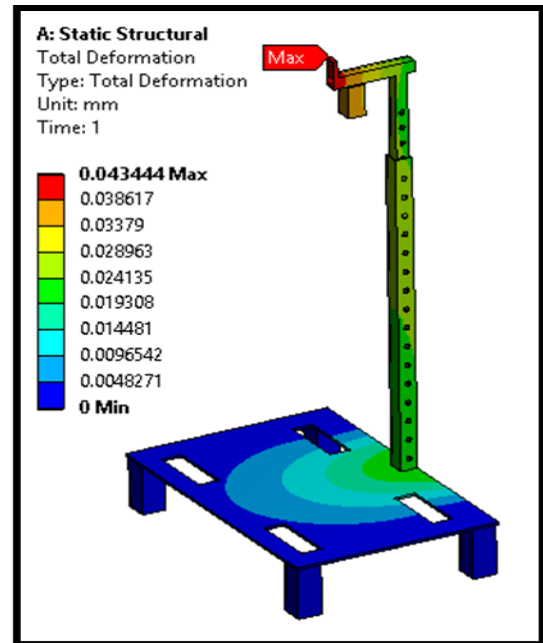

### 8.2 Equivalent stress

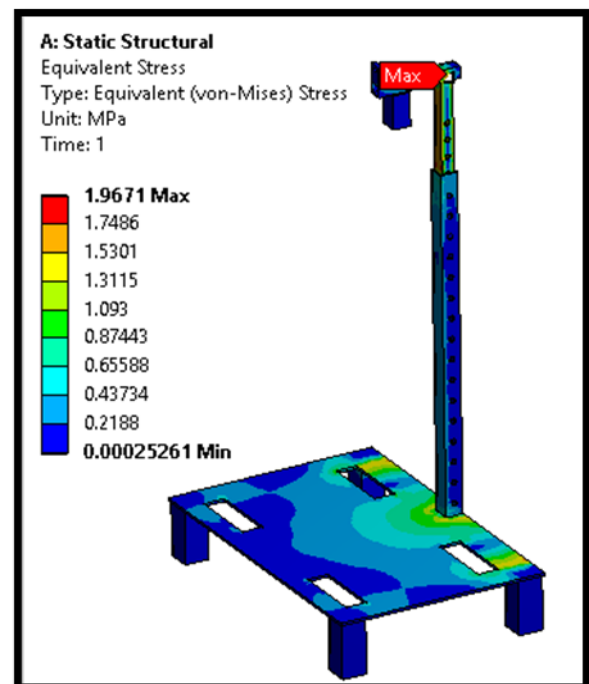

1. From the analysis results, it is clear that the maximum stress induced is less than that of the yield strength. So, the design is safe.

2. This machine is effective & efficient than the available methods.



3. Time taken by using the machine to clean the valve is considerably less as compared to the traditional method by almost 12 mins.

### 9. Concluding Remarks:

1) Hence concluded that the conventional methods used for cleaning the valves is more tedious and time consuming. Due to the development of automated mechanism the job got easier and the cycle time is also reduced.

2) Valve lapping mechanism will be implemented replacing manual labour.

3) Due to development of semi-automated mechanism for valve lapping the mechanical effort required is being also reduced.

4) Valve lapping mechanism will be designed as an assembly of several parts easing any maintenance to the machine.

### 10. References:

- [1] Avinash Kumar Agrawal<sup>1</sup>, Shrawan Kumar Singh<sup>2</sup>, Shailendra Sinha<sup>1</sup> And Mritunjay Kumar Shukla<sup>1</sup>, "**Effect of EGR on the exhaust gas temperature and exhaust opacity in compression ignition engines**", Vol. 29, Part 3, pp. 275-284 June 2004.
- [2] S. M. Fulmali, R.V. Chadge "**Need of valve lapping machine for valve component**", International Journal of Modern Engineering Research IJMER, Vol. 2, Issue. 6, pp4609-4612, Nov.-Dec. 2012
- [3] Prof. D. Kotkar, Pankaj Pujari, Chetan Arote, Tushar Kale, Kiran Kawale, "**Design and Development of Valve Lapping Machine**", International Journal of Engineering Research & Technology (IJERT), Vol. 8 Issue 06, June-2019.
- [4] Ayodhya Abeysekara, "**Valve Lapping Machine for Internal Combustion Engines**" International Journal of Engineering Research & Technology (IJERT), Vol. 3 Issue 06, Feb 2015.
- [5] Eraldo Jannone da Silva, Eduardo Carlos Bianchi, João Fernando Gomes de Oliveira, Paulo Roberto de Aguiar, "**The Inlet Engine Valves Grinding Using Different Types of Cutting Fluids and Grinding Wheels**", Materials Research, Vol. 5, No. 2, 187-194, 2002.
- [6] M. R. Pratheesh Kumaret, M.R. Pratheesh Kumar, B.S Arun, R. Aravind Babu, "**Optimization of Process Parameters in Lapping of Stainless Steel**", International Journal of Engineering Research & Technology (IJERT), 2013.
- [7] S. M. Fulmali, R.B. Chadge, "**Need of Lapping Machine for Valve Component: A Case Study**", International Journal of Modern Engineering Research (IJMER), 2012.
- [8] Owat Sunanta, "**Flat surface lapping: process modeling in an intelligent, Environment**", University of Pittsburgh, 2002.
- [9] G.D. Roy, S.M. Frolov, A.A. Borisov, D.W. Netzer, "**Pulse detonation propulsion: challenges, current status, and future perspective**" Prog. Energy Combust. Sci. 30 (6) 545e672, 2004.
- [10] P. Dominique, P. Alban, S. Laurent, "**Performance of a Valveless Air-Breathing Pulse Detonation Engine**", American Institute of Aeronautics & Astronautics, pp. 2004-3749, 2004.
- [11] Xiobin le and M.L. Peterson, Dept of Mechanical Engineering, Colorado State University, "**Material removal rate in flat lapping**", **Journal of Manufacturing Systems**.
- [12] C.J. Evans and E. Paul, Zygo Corporation, Middlefield, USA, "**Material Removal Mechanisms in Lapping and Polishing**", **CIRP Annals -Manufacturing Technology**".
- [13] Lalit Suhas Deshpande, Shivkumar Raman, Owat Sunanta, University of Oklahoma, United States, "**Observations in flat lapping of stainless steel and bronze**", International journal of Science and Technology of friction, lubrication and wear.
- [14] H.Y. Tam, H.Y. Tam, Y.W. Wang, Department of manufacturing engineering and engineering management, City university of Hong Kong, "**Removal rate and surface roughness in the lapping and polishing of RB-Sic optical components**", Journal of Materials Processing Technology.