

To Conduct Fluid Structure Interaction & Test The Feasibility Of Metal Matrix Composite For Journal Bearing

Student Name*, **Dr. Shaileah Gupta****, Prof. Gouraw Beohar***

* **Sujeet Kumar Panika**, Department of Mechanical Engineering, SHRIRAM INSTITUTE OF TECHNOLOGY, JABALPUR MP.

** Prof. Gouraw Beohar, Department of Mechanical Engineering, SHRIRAM INSTITUTE OF TECHNOLOGY, JABALPUR MP.

Abstract: The journal bearings are used in various engineering components, combustion engines and turbines. The current research reviews the existing work in design and analysis of journal bearings. The type of materials for journal bearings, fluid type is assessed by various scholars and presented in the current review. Different researchers have conducted study on journal bearings using experimental and numerical techniques is presented.

Key Words: Journal Bearing, FSI

1. INTRODUCTION:

Journal bearings are a common engineering component that can be found in practically any machine. To achieve great efficiency and dependability, combustion engines and turbines rely almost entirely on journal bearings [1].

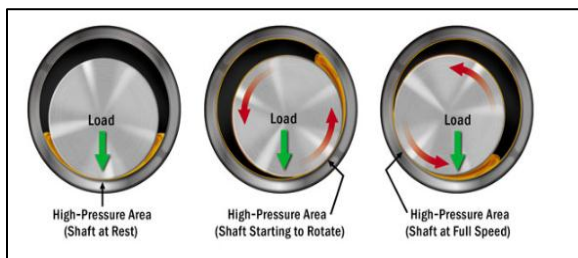

Figure 1: Journal Bearing [27]

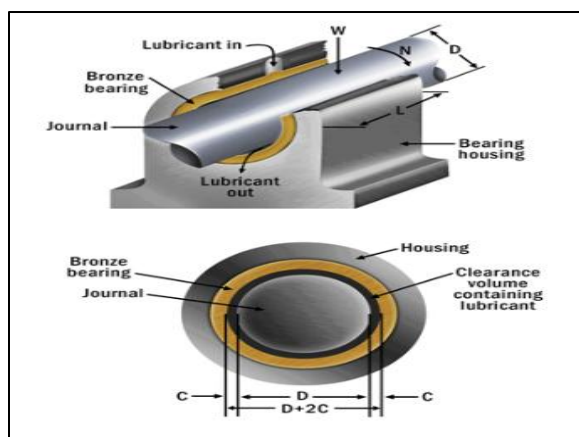

Figure 2: Journal Bearing structure [27]

A radial bearing consists of a rotating shaft (link) and a fixed housing, as shown in Figure 2. A hydrodynamic film is formed between the moving surfaces of the shaft and the moving surfaces of the housing to carry the load. Because the operating surfaces of such bearings are completely separated by a lubricating film, the coefficient of friction is kept low, around 0.005, and bearing failure is rare, occurring only after improper handling. [2].

2. LITERATURE REVIEW

Boedo and Eshkabilov et. al. [3] have conducted research on journal bearings to optimize the shape of fluid film. The analysis is conducted under steady state journal rotation condition. Using the optimization techniques, the load capacity is maximized and an optimum design of journal bearing is presented using genetic algorithm with certain constraints. From the optimization, the multiple optimization results are obtained.

Hirani and Sut et. al. [4] have conducted numerical investigation on journal bearing (fluid-film) in order to improve the operating characteristics. The numerical method used in the analysis is finite difference mass conserving algorithm to determine accurate flow rate. Pareto optimal concept to avoid "subjective decision on priority of objective functions, a genetic algorithm to deal with multimodal nature of hydrodynamic bearing and develop a Pareto optimal front, fitness sharing to maintain genetic diversity of the population used in genetic algorithm, and axiomatic design to provide inside of objective functions and design variables. Algorithm for the optimum design of short journal bearings. The optimized results were compared with those of genetic algorithm and

successive quadratic programming. All the results have the same tendency. The artificial life algorithm only uses the function value and doesn't need derivatives calculated analytically or numerically and so it has a strong possibility for being used for other optimization problems" [4].

An analysis of lubricated conformal contact is performed by Cupillard et al [5] to study the effect of surface texture on bearing friction and bearing capacity using computational fluid dynamics. The work focuses on a radial bearing with several dimples. Two- and three-dimensional bearing geometries are considered. The full Navier-Stokes equations are solved under steady-state conditions with a multiphase flow cavitation model. The coefficient of friction can be reduced by introducing a texture of suitable geometry. This can be achieved either in the region of maximum hydrodynamic pressure for a bearing with a high eccentricity ratio or just beyond the maximum film for a bearing with a low eccentricity ratio. At low eccentricity ratios, a further increase in pressure due to surface texture was demonstrated.

Bhuptani and Prajapati [6] performed an evolutionary optimization methodology for a solid journal bearing. The effect of minimization of temperature rise, minimization of oil flow, minimization of weighted sum of oil flow and temperature rise, and linear combination of minimization of oil flow and power loss under various constraints are demonstrated. The results lead to the recommendation to use simultaneous minimization of oil flow and power loss. Pareto-optimal concepts are used to help a win-win situation between power loss and oil flow. Optimization studies are performed with three design variables. An orthogonal array is used to select and set the values of design variables and tolerances. The results show that oil viscosity is the most important. Therefore, special attention should be paid to the viscosity of the lubricant when designing the bearings.

Kalakada et al [7] have conducted research on performance of journal bearing using experimental techniques. In the research the performance of journal bearing is evaluated under static and dynamic loading conditions. From the analysis, the load capacity, end leakage and frictional force is evaluated for different nanofluids i.e. copper oxide (CuO), cerium oxide (CeO₂) and aluminum oxide (Al₂O₃). The research findings have shown that performance characteristics of journal bearing is not affected by presence of nanofluids. However, significant changes are observed for thermoviscous case as shown in figure 3.

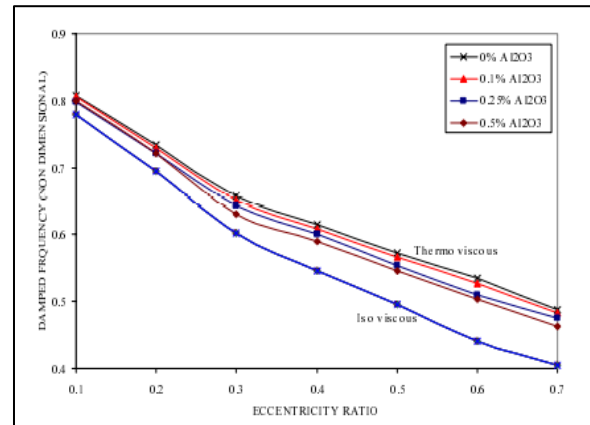

Figure 3: Al₂O₃ nanoparticles concentration effect on journal bearing

Kango et al [8] have conducted experimental investigation on journal bearings with different shapes of microcavities. In the research, the effect of cavity width, cavity depth on bearing surface is evaluated. The research findings have shown that the negative texture has significant effect on improving lubricant film thickness and with reduction in friction force.

Han and Fu et. al. [9] have conducted research on plain journal bearing using experimental techniques. The experimental testing is conducted to evaluate the effect of micro-grooves on performance of journal bearing. The misaligned bearing, plain bearing are both analysed in the research.

Li et al. [10] established the nonlinear transient hydrodynamic force model based on a new structured mesh movement algorithm. They found that the difference between the linear and nonlinear hydrodynamic forces of multiple grooves water-lubricated journal bearings was considerable.

Machado et al. [11] have conducted both experimental and numerical investigation on journal bearing to evaluate the effect of oil film forces. The linear approximation is done to determine its validity for the system operating under specific conditions. The numerical results are in close agreement with the experimental findings for nonlinear bearings.

Zhang et al. [14] have conducted numerical investigation on journal bearing using finite length model. The analysis is conducted to obtain the oil pressure distribution. The effect of different operational parameters on the oil film forces are presented. The "dynamic coefficients are another expression of fluid-induced force of journal

bearing, which can be integrated in the coefficient matrix of motion equations for rotor-bearing system" [14].

Yang et al. [15] have conducted analytical study on tilting pad bearing to evaluate damping coefficients and dynamic stiffness. The novel analytical method is proposed by the researcher to overcome ill conditioned matrix. The coefficient damping is evaluated for circular journal bearing [16].

Li et al. [17] have conducted numerical investigation on journal bearing using techniques of Computational Fluid Dynamics (CFD) tool. From the CFD tool, the dynamic coefficients of journal bearings are evaluated. The results obtained from CFD analysis are compared with experimental findings. The stiffness and damping coefficients of journal bearing are then evaluated [18-20].

Tala-Ighil and Fillon et. al. [21] have conducted numerical investigation on journal bearing using finite difference method. From the research the effect of texture presence and absence of friction characteristics of journal bearing is evaluated. The research findings have shown that by texturing the bearing surface, the thermal effect is found to be in close agreement with experimental data.

Chen et al. [22] have conducted research on aerostatic journal bearing using experimental techniques. The analysis is conducted using Reynolds equation to evaluate the aerostatic properties. The effect of geometric properties like waviness, misalignment and manufacturing errors on structural characteristics of journal is also evaluated [23-25].

Zhou et al. [26] have conducted numerical investigation on journal bearing to using simulation package. The analysis involved secant method to determine the efficiency and static performance of journal bearing.

3. CONCLUSION

Proper design of journal bearing is vital for proper functioning of various machine components. Various researches are conducted to determine the factors affecting load capacity, attitude angle threshold speed and damped frequency of journal bearing. Different optimization studies are conducted by various researchers and its shown that minimizing oil flow could cause increase in temperature. The effect of different operational parameters, design parameters on journal bearing is evaluated.

REFERENCES

- [1] Gwidon W. Stachowiak. Engineering Tribology. United Kingdom. Butterworth-heinemann Vol. 14 pp.26-31 ,2017.
- [2] F.M. Meng . L. Zhang . Y. Liu . Effect of compound dimple on tribological performances of journal bearing. TribolLett Vol 12, pp. 55-61, 2015
- [3] Boedo, S. and Eshkabilov, S. L. Optimal shape design of steadily loaded journal bearings using genetic algorithms. STLE Tribology Trans., Vol. 46, Issue 1, 134-143, 2003.
- [4] Hirani, H., and Suh, N.P., Journal Bearing Design Using Multi Objective Genetic Algorithm and Axiomatic Design Approaches, J. Tribology International, Vol. 38, pp 481-491, 2005.
- [5] S Cupillard, S Glavatskih, and M J Cervantes, "Computational fluid dynamics analysis of a journal bearing with surface texturing", Proceeding of the Institution of Mechanical Engineering, Part J: Journal of Engineering Tribology, Vol. 222, Issue 2, pp 97-107, 2008.
- [6] Bhuptani Kirankumar M., "A brief review on Optimum Design of A Journal Bearings for I.C. Engine", International Journal of Engineering Research & Technology, Vol. 4, Issue 4, 2012.
- [7] K. B. Kalakada, P. N. Kumarapillai, R. K. Perikinalil, "Analysis of Static and Dynamic Performance Characteristics of THD Journal Bearing Operating Under Lubricants Containing Nanoparticles", International Journal of Precision Engineering and Manufacturing Vol. 13, No. 10, pp. 1869-1876, 2012
- [8] S. Kango, D. Singh · R.K. Sharma, "Numerical investigation on the influence of surface texture on the performance of hydrodynamic journal bearing" *Mechanica*, Vol. 47, pp 469-482, 2012
- [9] Han Y, Fu Y. Comparison of hydrodynamic characteristics between circumferential and transversal microgrooved journal bearings. *Lubr Sci* 2019;31(7):285-98.
- [10] Li Q, Zhang S, Wang Y, Xu W, Wang Z, Wang Z. Dynamic characteristics of water-lubricated journal bearings-Part 1: full 3D transient hydrodynamic force models using structured mesh movement algorithm. *Mech Ind* 2019;20 (4):404.

- [11] Machado TH, Alves DS, Cavalca KL. Discussion about nonlinear boundaries for hydrodynamic forces in journal bearing. *Nonlinear Dyn* 2018;92(4):2005–22.
- [14] Zhang Y, Hei Di, Liu C, Guo B, Lu Y, Müller N. An approximate solution of oil film forces of turbulent finite length journal bearing. *Tribol Int* 2014;74:110–20.
- [15] Lihua Y, Huiguang Li, Lie Yu. Dynamic stiffness and damping coefficients of aerodynamic tilting-pad journal bearings. *Tribol Int* 2007;40(9):1399–410.
- [16] Chen C, Jing J, Cong J, Dai Z. Identification of dynamic coefficients in circular journal bearings from unbalance response and complementary equations. *Proc Inst Mech Eng Part J: J Eng Tribol* 2019;233(7):1016–28.
- [17] Li Q, Zhang S, Ma L, Xu W, Zheng S. Stiffness and damping coefficients for journal bearing using the 3D transient flow calculation. *J Mech Sci Technol* 2017;31(5):2083–91.
- [18] Dyk Š, Rendl J, Byrtus M, Smolík L. Dynamic coefficients and stability analysis of finite-length journal bearings considering approximate analytical solutions of the Reynolds equation. *Tribol Int* 2019;130:229–44.
- [19] Weimin W, Lihua Y, Tiejun W, Lie Y. Nonlinear dynamic coefficients prediction of journal bearings using partial derivative method. *Proc Inst Mech Eng, Part J: J Eng Tribol* 2012;226(4):328–39.
- [20] Merelli CE, Barilá DO, Vignolo GG, Quinzani LM. Dynamic coefficients of finite length journal bearing. Evaluation using a regular perturbation method. *Int J Mech Sci* 2019;151:251–62.
- [21] Tala-Ighil N, Fillon M. A numerical investigation of both thermal and texturing surface effects on the journal bearings static characteristics. *Tribol Int* 2015;90:228–39
- [22] Chen X, Mills JK, Bao G. Static performance of the aerostatic journal bearing with grooves. *Proc Inst Mech Eng, Part J: J Eng Tribol* 2020;234(7):1114–30.
- [23] Wang X, Xu Q, Wang B, Zhang L, Yang H, Peng Z. Effect of surface waviness on the static performance of aerostatic journal bearings. *Tribol Int* 2016;103:394–405.
- [24] Wang X, Zhou L, Huang M, Yue X, Xu Q. Numerical investigation of journal misalignment on the static and dynamic characteristics of aerostatic journal bearings. *Measurement* 2018;128:314–24.
- [25] Cui H, Wang Y, Yue X, Huang M, Wang W. Effects of manufacturing errors on the static characteristics of aerostatic journal bearings with porous restrictor. *Tribol Int* 2017;115:246–60.
- [26] Zhou W, Wei X, Wang L, Wu G. A superlinear iteration method for calculation of finite length journal bearing's static equilibrium position. *R Soc Open Sci* 2017;4(5):161059. doi: <https://doi.org/10.1098/rsos.161059>.
- [27] [Determining Proper Oil Flow to Journal Bearings \(machinerylubrication.com\)](http://www.machinerylubrication.com)