

AUTOMATIC HYPODERMIC INFUSION REGULATOR

Dr. V. Dooslin Mercy Bai¹, Aswin Nekomian.S², Sharanyaa.G³, Naveen.J⁴, John Abraham.N⁵

¹ Professor, Department of Biomedical Engineering, Sri Shakthi Institute of Engineering and Technology,
^{2,3,4,5} Under Graduate students, Department of Biomedical Engineering, Sri Shakthi Institute of Engineering and Technology,
Coimbatore, Tamil Nadu-641062

Abstract -In the Clinical field, numerous gadgets present a radical change for checking the patient and are considerably more programmed like our proposed technique for the Brilliant Intravenous Framework. Intravenous (IV) organization of meds is quite possibly the most widely recognized process in the treatment of hospitalized patients. Iv treatment is regularly utilized for rehydration and to give patients prescriptions or supplements in the event that they can't eat when an individual is in the emergency unit, likewise, during disease treatment and agony the board utilizing specific drugs likewise is pivotal to assist a person with making a rapid recuperation. While controlling IV liquids to a patient, the medical caretaker should consistently screen the patient's liquid and electrolyte status to assess the imbue's viability and keep away from likely difficulties of liquid over-burden and electrolyte lopsidedness. The most regularly utilized essential IV liquid pack contains 1,000 ml. Albeit intravenous liquid organization is one of the most often performed nursing errands. Unfortunately, due to their hectic schedules, the observer may forget to change the bottle at the proper time, and nurses may not be able to manually check the drip conditions and drip level of each patient on a regular basis. This puts patients at risk for health problems and can even worsen their condition; many patients have even passed away as a result. Our IoT-based Automatic Hypodermic Regulator prototype, which is a process of measuring and solving the issues of bubble formation in drips and gives a notification for some levels of IV bag through LED, buzzer, and also stops the fluid flow in the critical stage using a solenoid valve then utilize the GSM Module to send the alert message.

KEYWORDS: load cell Amplifier, weight sensor, Arduino, Solenoid valve

INTRODUCTION

While a person is undergoing surgery, both during and after the procedure, while receiving cancer treatment, or when they are unable to eat, IV therapy is frequently used to rehydrate patients. It is also important to employ specific medications for pain management in order to aid in a quick recovery. Fluids given to a patient intravenously or through the veins while receiving intravenous therapy

are stored in an IV bag. Fluids include things like blood for blood transfusions, medicine mixes, and saline for hydration. The delivery of medications or fluids intravenously ensures that they are transported as quickly as possible through the bloodstream to all areas of the patient's body. IV therapy utilizing an intravenous bag is frequently referred to as an IV "drip" to distinguish it from an IV bolus, also known as an IV "push," which is a syringe injection directly into a vein via an IV cannula, or through an injection port on the bag. Nonetheless, IV drips require routine inspection and replacement. Depending on the patient and their condition, the fluid flow must also be measured. To give the fluid a stress caused by gravity force electrical that surpasses the circulatory pressure, a bottle full with the appropriate fluid cure is hung at a height higher than the patient's body. The current drip tracking mechanism is manual and requires a nurse or a doctor to monitor the patient's infusion setup. They want to estimate how long a bottle will take to drain historically, and regular rounds are needed to control the flow rate and prevent any bubble formation that makes the manual drip monitoring system susceptible to human error. The bottle is typically changed while being entirely empty. Unfortunately, because of their schedule, the observer can forget to adjust or stop the drip bottle at the proper time. This could cause the sufferers to have several issues. Regular monitoring is essential since even a small human error could endanger a patient's health, making IV therapy monitoring crucial. Nurses are unable to properly check each patient's IV bag level. Because of this, our proposed design for a smart the intravenous device represents the future of the healthcare sector. This research offers a method for hospitals to effectively handle this circumstance; our suggested solution is to create an IV fluid monitoring system that measures the weight of the IV bag and alerts the fluid level with the use of LED and critically low ways. The IV system's solenoid valves automatically shut down the flow of a liquid in response to a buzzer alert. uses GSM technology to send a message to the nurse.

II LITERATURE SURVEY

The system uses an Arduino Uno, a load cell amplifier, a load cell sensor,sg90 servo motor, an LED, and a buzzer. The Load Cell and Amplifier will both be linked to the Arduino Uno. An amplifier and solenoid valve will be

positioned at the bottom of the infusion tube, and a load cell sensor will be fastened to the top of the glucose bottle. Data from sensors is retrieved and calculated using an Arduino UNO. The android application will be provided with the estimated sensor data to alert the nurses to fluid levels and the development of bubbles in the drip. [1].

At the start of the case, the FIVATM device was fastened to a 100 mL saline bag. Data were gathered from 93 vitrectomy cases that were each randomly assigned to the device ON or OFF groups. The FIVATM device's ON/OFF status was concealed from the anesthesiologist, who also received usage instructions. Each group's frequency of activated alarms and missed dry IV bags was recorded. At the conclusion of each case, the participant answered a questionnaire about the device's usability. Due to false alarms being discovered as a result of the unanticipated movement of the IV bag or IV pole, two cases had to be excluded. The average (standard deviation) time for the procedure was 58.5 (16.9) minutes. Overall, the anesthesiologists missed the 50 percent of the 91 IV bags that ran dry. Zero IV bags ran dry in the ON group without being noticed; instead, 21 (47%) bags sent off an alarm when they did, and 24 (53%) bags were changed by the participating anesthesiologists before they did. In the OFF group, 25 (54%) bags ran dry undetected, while the participating anesthesiologists refilled 21 (46%) bags before they ran out. [2].

The ESP8266 wireless module transmitter, 16*2 LCD, power supply, buzzer, IR sensor, keypad, and Arduino UNO (based on Microchip ATmega328P) make up the dependable, reasonably priced saline monitoring system transmitter portion. The nurse receives all real-time data from the transmitter part into an application on their smartphone, which serves as the reception part. The smartphone receives data from the server in real-time once the transmitter broadcasts it. [3].

The ESP8266, ARM, Load Cell, Solenoid Valve, Keypad, Relay, and ESP8266 make up the glucose monitoring system. The weight of the drip bottle is calculated using an electronic load cell, and information about it is relayed to the doctor via a WIFI module. We are sending information to a basic Android mobile app for presentation purposes. As the bottle reaches the threshold level, it becomes intimate for medical professionals and hospital staff. By issuing commands from a mobile device, specialists can regulate the stream rate. When the container weight becomes completely empty [4].

The system makes use of temporal and geographic position data from the Global Positioning Satellites. Most bag tracking devices rely on GPS and GSM technology. All mobile phones have a feature called Short Messaging Service (SMS) that enables users to send brief text messages to one another. At least five of the 24 satellites in

the GPS constellation are visible from any location on Earth thanks to their placement in six different 12-hour orbital paths. Currently, GPS is used for a variety of other purposes, such as bag tracking. [5].

A flow meter, microprocessor, actuator, Wi-Fi module, and buzzer are all parts of the proposed gadget. At first, the flow meter continuously monitors the fluid level inside the tube, and once it exceeds the threshold, it sends a warning signal through Wi-Fi and the NODEMCU board to the nurse station and bystander. It also activates an actuator to stop the flow at the same moment. The nursing station's microcontroller recognizes the signal and displays the patient's bed number by LED indication as a result.[6]

The present method uses deep learning computer vision techniques to monitor the flow rate of IV infusions. In essence, a camera records the drip chamber, and object detection is utilized to count the drips. So, compared to other techniques created for this aim, the suggested one is less invasive. The results of the experiments demonstrate its ability to generate a precise real-time estimate of the drip's instantaneous flow rate. These factors make the suggested approach a useful one to use in the implementation of monitoring and control systems for healthcare institutions. [7]

III METHODOLOGY

The system is made up of an Arduino Uno, a Load cell sensor, a Load cell Amplifier, a Solenoid valve, a GSM module, a Buzzer, and four different colors of LED. The IV bag weight is measured by the load cell sensors which are fastened to the drip bottle's top, and the data is amplified by a load cell amplifier. Both are managed by an Arduino Uno, which allows for quick programming division and warnings via an LED and buzzer. Based on the fluid level in the IV bag, if it is less than 10%, the buzzer will activate.

The IV set tube is attached to the solenoid valve. While the buzzer is on simultaneously relay switches on and automatically solenoid valve turns off and stops the fluid flow, with the help of GSM module to send an alert notification.

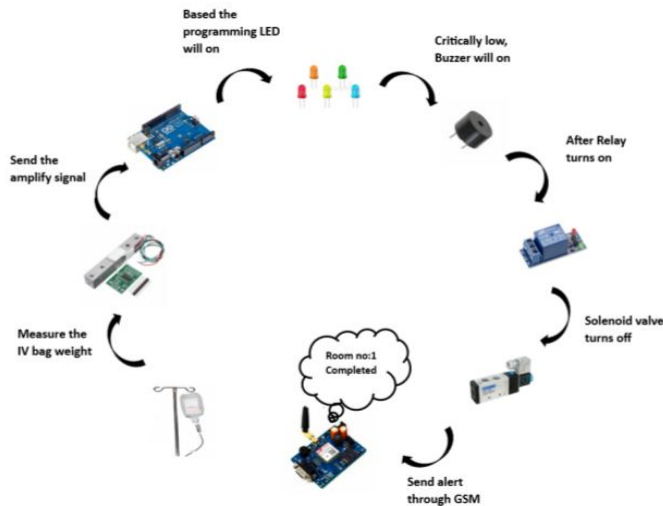

Fig 1 WORKFLOW DIAGRAM OF AUTOMATIC HYPODERMIC INFUSION REGULATOR

A) Design

The two goals for the design of this system are:

- Monitoring the level of the fluid in the bottle. To measure the level of the fluid, a load cell sensor is mounted to the top of the glucose bottle.
- The value sends to the amplifier and amplify signal send to Arduino. Based on the fluid level indications through LED. The indications category below

Table 1: Level in drip from Load Cell Amplifier

S.NO	L (level of IV left in bottle) (cm)	LED Indication
1	100%	BLUE
2	75%	GREEN
3	50%	YELLOW
4	25%	RED
5	<10%	BUZZER

When the level is critically low then the Arduino sends a trigger to the Buzzer. Then Relay module turns on and solenoid turns off, gives the alert message for the nurse/Assist through GSM Module.

B) Working

The algorithm of the Automatic Hypodermic Regulator, which is a combination of a system for detecting and

signaling liquid levels in an IV bottle and LED indication for monitoring the state of IV infusions in real-time. The RESET button must be pressed after the device has started in order to reset the system to its factory default settings. Using the Wheatstone bridge principle, a sensor will work. Four types of resistance exist. Each resistance is positioned between two nodes; three of the resistances are constant,

while one is variable. A variable resistance will output an exact weight to the amplifier when external pressure is applied to it. A slight strain or force can also be used to get an accurate weight. Millivolts will be the output format. The weak waveforms will be strengthened by the loadcell amplifier. According to its own principles, it transforms the loadcell's output into a voltage that it then provides as an input to the Arduino. Because the Arduino lacks a feature for calculating the current. The Load cell calculates the weight of Glucose Bottle and the load cell Amplifier amplifies the signals and send to the Arduino Uno. LED shows the Iv Bag Fluid level. Once the IV bag running dry its start the indication. In the initial stage green Led glows it means the bottle level is full. Blue led glows it means the bottle level is maximum. Yellow led glows it means the bottle level is half. Red led glows it means the bottle level is minimum and once buzzer on it indicates glucose level is critically low. After that Relay module will turns on and Solenoid valve will turn off and stop the fluid flow. Send the alert message to nurse/assist through GSM Module. Reset the system using RESET BUTTON.

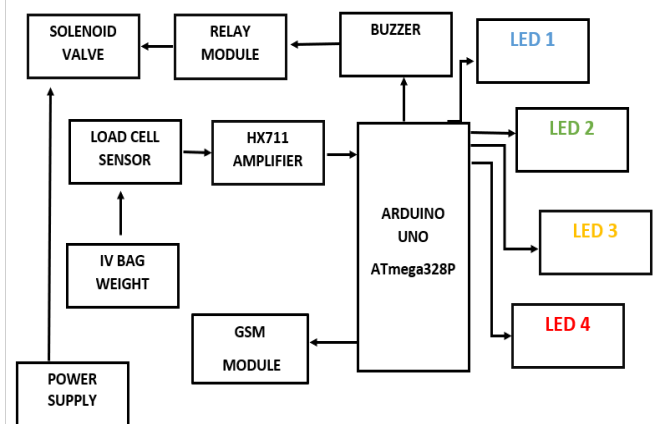

Fig 2 BLOCK DIAGRAM OF AUTOMATIC HYPODERMIC INFUSION REGULATOR

RESULT

We have also brought our idea into reality. There are some attached images of how an IV bag refill system will work and look in real life, when used by nurses on patients in hospitals. Figure 3,4 shows the output of our design.



Fig 3 Here IV Bag fluid level is critically low so RED color LED is HIGH and the RELAY MODULE is ON to switch on the solenoid valve to stop the fluid flow

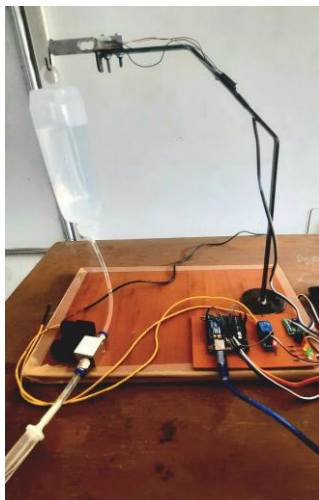

Fig 4 Here IV Bag fluid level is maximum (75%) so GREEN color LED is HIGH.

CONCLUSION

Hence this proposed project helps the hospital staff by sending alerts about the glucose bottle and stop that waiting for replace the new bottle. The suggested work decreases the amount of time and effect required to monitoring the intravenous bag. It is not necessary to physically check the glucose level on a regular basis. The patients will benefit greatly from this, especially at night. Additionally, because air bubbles in blood can instantly kill a patient, this technique eliminates the deadly chance of them getting into their bloodstream. enhance patient health outcomes, assist nurses in carrying out their responsibilities, and keep an eye on the IV bag. It can also be used for drainage bags during postoperative care or

urine bags in immobile patients. It can also be fitted in any ambulance, mobile hospital, or hospital room. Literally, the Automatic Hypodermic infusion regulator is replaced nurse. Basically, a technology made for reduce the need of human, and this device achieve that.

ACKNOWLEDGMENTS

We acknowledge the support from the Dr. V. Dooslin Mercy Bai, Professor, Department of Biomedical Engineering, SIET, Coimbatore, Tamil Nadu.

REFERENCES

- [1] Satwik Tanwar, Deepa.K,Riddhi Maniktalia, Ritvik Billa ,“IOT Based Drip Monitoring System”, “International Journal of Science and Research (IJSR)”,Volume 10 Issue 12, December 2021.
- [2] Mohamed Eissa, MD . Karim Wafa, MD, PhD . Orlando Hung, MD, “The use of the Fluid IV Alert monitor to decrease the incidence of undetected empty intravenous bags in dimmed operating rooms”, “spinger”, 68:1266–1267, 3 May 2021.
- [3] Shohag Hossain , Shraboni Sharmin , Tasnuva Faruk, “Low-Cost Digitization of Infusion Pump for Real time Automated Flow Rate Monitoring and Warning”, “International Conference on Innovation in Engineering and Technology (ICIET)” IEEE Xplore, 23-24 December, 2019.
- [4] Rakhi Varma¹, Pooja Pavsh, Akshay Bhadane, Shrushti Pagare, “IoT BASED INTRAVENOUS FLOW MONITORING SYSTEM”, “International Research Journal of Engineering and Technology (IRJET)”, Volume: 07 Issue: 05 | May 2020.
- [5] Anagha R, Ashwini S, Keerthana G, Monica M, “IoT BASED INTRAVENOUS FLOW MONITORING SYSTEM”, “International Research Journal of Engineering and Technology (IRJET)”, Volume: 07 Issue: 05 | May 2020.
- [6] Elizabeth Liza Mathew¹, Jeelson K James², Aparna Radhakrishnan, “The Novel Intravenous Fluid Level Indicator for Smart IV Systems”, International Research Journal of Engineering and Technology (IRJET), Volume: 07 Issue: 06 | June 2020.
- [7] Nicola Giaquinto, Marco Scarpetta, Mattia Alessandro Ragolia, “Real-time drip infusion monitoring through a computer vision system”, UTC from IEEE Xplore, August 01,2020.
- [8]-A.Kurniawan, NodeMCU Development Workshop, PE Press, Riverside, CA, USA, <https://books.google.com.lb/books?id=XP9ICgAAQBAJ-2017>

- [9]-RP.Foundation, Raspberrypi modelb, <https://www.raspberrypi.org/products/raspberry-pi-3-model-b-plus/>.2017
- [10] R.Vasuki, C.Dennis, HemPriya Changer, "An portable monitoring device of measuring drips rate by using an Intravenous (IV) set", International Journal of Biotechnology Trends and Technology Vol. 1, Issue 3, No.4 2018.
- [11]C.C.Gavimath, Krishnamurthy Bhat, C.C.Chayalakshmi, R.S.Hooli, B.E.Ravishankera "Design and Development of versatile saline flow rate measuring system and GSM based remote monitoring device", International Journal Of Pharmaceutical Applications ISSN 0976- 2639,jun 11,2018.
- [12] R.Aravind, Syed Mustak Ahmed "Design of family health monitoring system using wireless communication", International Journal of Advanced Research in Computer and Communication Engineering Vol. 2, Issue 9, September 2018
- [13]J. T. Co and A. Baba, Find Quality Wholesalers, Suppliers, Manufacturers, Buyers and Products from Our Award-Winning International Trade Site. Wholesale Products from china Wholesalers at aliexpress.Com, <http://www.aliexpress.com/item/GOOD-With-Hall-speed-measurement-DC-gear-motor-Big-torque-DC12V-75-1-High-grade-Car/32844986762.html>.-2018
- [14]G. Hajj-Moussa, A. Sayed-Kassem, N. Kozah, R. Harb, M. Arnaout, and A. J. Zaylaa, "Prototype-2019.
- [15]G. Hajj-Moussa, A. Sayed-Kassem, N. Kozah, R. Harb, M. Arnaout, and A. J. Zaylaa, "Prototype advancement of the robotic iv pole: preliminary simulation," in Proceedings of the International Conference on Computer and Applications (ICCA), IEEE, pp. 71–74, Beirut, Lebanon, 2019.
- [16]Fraunhofer-Gesellschaft: Research News. Safe. IV Therapies in Developing Countries–Reducing Mortality with an Electronically Controlled Infusion Set; Fraunhofer: Munich, Germany, 2020; pp. 1–4. Available online: <https://www.fraunhofer.de/en/press/research-news/2020/september/reducing-mortality-with-an-electronically-controlled-infusion-set.html> (accessed on 12 November 2019).
- [17] Hindley, G. Infection control in peripheral cannulae. Nurs. Stand. 2004, 18, 37–40. [CrossRef] 3. Millam, D.A. Managing complications of i.v. therapy (continuing education credit). Nursing 2019
- [18]. Ajibola, O.O.E.; Sunday, O.O.; Eyehorua, D.O.Development of automated intravenous blood infusion monitoring system using load cell sensor. J. Appl. Sci. Environ. Manag. 2019
- [19] Shelishiyah, R.; Suma, S.; Reji, J.R.M. A system to prevent blood backflow in intravenous infusions. In Proceedings of the 2nd International Conference on Innovations in Information, Embedded and Communication Systems (ICIIECS), Coimbatore, India, 19–20 March 2020
- [20] Bhavasaar, M.K.; Nithya, M.; Praveena, R.; Bhuvanewari, N.S.; Kalaiselvi, T. Automated intravenous fluid monitoring and alerting system. In Proceedings of the IEEE Technological Innovations in ICT for Agriculture and Rural Development (TIAR), Chennai, India, 15–16 July 2020
- [21] Ramisha, R.K.; Shabana, N.; Tanmayee, P.; Loganathan, S.; Velmathi, G. Smart drip infusion monitoring system for instant alert-through nRF24L01. In Proceedings of the International Conference on Nextgen Electronic Technologies: Silicon to Software (ICNETS2), Chennai, India, 23–25 March 2020
- [22] Cohen, L.; Rose, R.A. Capacitance-Type Fluid Level Sensor for I.V., and Catheter Bags. U.S. Patent No. US5135485, 4 August 2020
- [23] Anand, M.; Pradeep, M.; Manoj, S.; Arockia Raj, L.M.; Thamaraikani, P. Intravenous drip monitoring system. Indo-Iran. J. Sci. Res. 2018, 2, 106–113. [CrossRef] 10. Pratim, R.P.; Thapa, N. A systematic review on real-time automated measurement of IV fluid level: Status and challenges. Measurement 2020
- [24] Priyadharshini, R.; Mithuna, S.; Vasanth, K.U.; Kalpana, D.S.; Suthanthira, V.N. Automatic intravenous fluid level indication system for hospitals. Int. J. Res. Appl. Sci. Eng. Technol. 2020.
- [25] Ogawa, H.; Maki, H.; Tsukamoto, S.; Yonezawa, Y.; Amano, H.; Caldwell, W.M. A new drip infusion solution monitoring system with a free-flow detection function. In Proceedings of the Annual International Conference of the IEEE Engineering in Medicine and Biology, Buenos Aires, Argentina, 31 August–4 September 2020
- [26] Makobore, P.N.; Mulerwa, M. An electronically controlled gravity feed infusion set for intravenous fluids. In Biomedical Engineering for Africa; Douglas, T.S., Ed.; University of Cape Town Libraries: Cape Town, South Africa, 2020
- [27] Sayed-Kassem, A.; Kozah, N.; Hajj-Moussa, G.; Harb, R.; Zaylaa, A.J. BMIVPOT, a fully automated version of the intravenous pole: Simulation, design, and evaluation. J. Healthc. Eng. 2020
- [28] LeFevre, R.J.; Thomas, R.E. Electronically Controlled Intravenous Infusion Set. U.S. Patent No. US4038981, 2 August 2020.

[29]. Cheng, T.-Y. Intravenous Drip Monitoring Method and Related Intravenous Drip Monitoring System. U.S. Patent No. US2011/0144595A1, 16 June 2020.

[30]. Moorthy, J.; Karunakaran, K.; Senthik, K.S.V. An automated locking system to prevent backflow of blood in an intravenous setup. Glob. J. Res. Eng. 2020