

# SMART BLIND STICK USING VOICE MODULE

Mrs.R.Abiramee<sup>1</sup>, Ms.P.Nithya<sup>2</sup>,Mr. M. Naveen Kumar<sup>3</sup>, Mr.T.E.Samrood Muhammed<sup>4</sup>,  
Ms.S.Sowmiya<sup>5</sup>

<sup>1</sup>Assistant Professor, Department of Biomedical Engineering, Sri Shakthi Institute  
Of Engineering and Technology

<sup>2,3,4,5</sup>Under Graduate students, Department of Biomedical Engineering, Sri Shakthi Institute  
Of Engineering and Technology, Coimbatore, Tamilnadu-641062

\*\*\*

**Abstract-** The concept of the smart stick aims to provide smart electronic assistance to the visually impaired. People who are blind or have low vision have difficulty recognizing obstacles as they walk down the street. The system is said to use the Arduino UNO and Voice Module to provide artificial vision and object detection, water detection, fire detection, and real-time support. The main goal of our project is to provide well-founded support for the visually impaired. Existing devices for the visually impaired focus only on moving from one location to another. This device is intended to assist the visually impaired with the same operations as a visually impaired person. Our project focuses primarily on the visually impaired, who are unable to move around independently. The system consists of ultrasonic sensors and feedback is received by voice. The system-wide goal is to provide visually impaired people with cost-effective and efficient navigation and obstacle detection assistance and artificial by providing information about scenarios around static and dynamic objects around them. It's about giving a sense and allowing them to walk independently.

**Keywords:** Ultrasonic sensors, Arduino UNO, RF module, Voice module

## 1. INTRODUCTION

A visually-aided person has difficulty seeing details with healthy eyes. People with 6/60 eyesight, or a horizontal area of vision with both eyes open, are below 20 degrees. These people are considered blind. Physical movement is a challenge for the visually impaired, as it can obscure the obstacles in front of them and prevent them from moving from one place to another. They rely on their families for mobility and financial support. Their agility prevents them from interacting with people and social activities. The proposed machine carries the ultrasonic sensor, water sensor, Voice module, and RF module. The stick measures the gap among the items and clever on-foot stick with the aid of using the usage of ultrasonic sensor. In this device, the ultrasonic sensors are used to come across boundaries with the aid of using the usage of ultrasonic waves. By sensing the boundaries, the sensor passes the obtained statistics to the microcontroller. The microcontroller strategies the statistics

and calculates if the impediment is nearly sufficient for the person. If the impediment isn't always near the microcontroller, the circuit does now no longer do anything. If the impediment is nearly sufficient for the microcontroller, it sends a sign to a buzzer. Although there is numerous current merchandise to assist visually impaired human beings which might be easy to be had inside the market, Our product indicates many advantages which can low cost, without problems usable, and portable.

## LITERATURE REVIEW

**Prutha G et al., May [2020]**, This paper introduces a stick that helps blind persons walk around on their own. Raspberry Pi and Arduino are used to monitor the stick. Water sensors are used to detect water and puddles, and three pairs of ultrasonic sensors are used to detect obstructions that are 15 cm in front of the users. The stick has interfaces for the aforementioned sensors. A dc motor allows the stick to autonomously decide whether to travel forward, backward, left, or right in response to the detection of an obstruction. Vibrations and buzzers will alert users. The stick with the flashlight attached can be seen by others, allowing him to pass. Navigation using GPS is provided with a finger ring. The user can maintain easily with fast response & low power consumption. The main purpose is to help visually impaired people for navigating independently.

**M Narendran1 et al., January [2018]**, With the aid of multidisciplinary fields like computer science, electronics engineering, and health science, the third eye for the blind is an innovation that enables blind people to navigate with confidence and speed by using ultrasonic waves to detect nearby obstacles and alert them with a buzzer sound or vibration. This wearable technology for blinds will be available. This device's key uniqueness is that it will be reasonably priced. One example of wearable technology is the Arduino Pro Mini 328-MHz 15/16 MHz board. This will be fitted with a module of ultrasonic sensors. With the help of the sensor, visually impaired people may navigate their surroundings and identify nearby items. The sensor will alert the user by beep or vibration when it discovers any object. This is automated and will be of a great use for the blinds and help them travel different places.

**Mohamed Dhiaeddine Messaoudi et al., June [2020],** Those who are visually impaired can use this "Smart Cane" technology to move more easily and avoid potential hazards. Using a white cane, using technological aids, and having a guide dog are currently the three primary options available to blind individuals. The answer that has been suggested in this article involves utilising a variety of technology tools to find a clever solution to the issue in order to make the consumers' lives easier. Using wireless scanners from the Internet of Things (IoT) and cloud computing, the developed system's primary goal is to facilitate interior navigation. Integrating several hardware and software technologies will enable the development of the Smart Cane to achieve its objective. The proposed solution of a Smart Cane aims to provide smooth displacement for the visually impaired people from one place to another. It provides them with a tool that can help them to communicate with the environment.

**Saurav Mohapatra et al., May [2018],** The walking stick-shaped working model that has a microcontroller system and an ultrasonic sensor built in is proposed. Using ultrasonic waves, the ultrasonic sensor is used to find obstructions. When it encounters obstructions, the sensor sends information to the microcontroller. After processing the data, the microcontroller decides whether the obstruction is close enough. If the obstacle is too far away, the circuit has no effect. The blind individual receives a warning from the microcontroller when an impediment is about to occur. We also plan to include the e-SOS (electronic Save Our Souls) mechanism. The e-SOS distress call button on the stick is pressed by a blind person if they have trouble navigating and they need to make a video call to a member of their family. A mobile device running Android streams the video. The location of the blind person to his family member is also sent using android application. Blind person is guided in this way to move along the path by his family member via the Android Mobile Application.

**S. Munirathnam et al., Apr [2018],** The main goal of the paper is to assist blind people in conversation. They have developed a clever structure that functions effectively both inside and outside. The current route planning tool for the visually impaired focuses on travelling from one location to the next. This focuses on developing a tool that enables visually impaired people to travel independently and that is also comfortable to use. The proposed gadget is used to manage blind or partially located individuals. The tool is used to enable blind people to move as confidently and easily as sighted people. In addition, it warns with a sound to stay away from obstacles in front of ultrasonic sensors and prevents slipping into water with a moisture sensor. It can even distract blind people from the current outdoor space, whether it is light or dark, using LDR. Using it, continuous monitoring of the client is possible. The whole device is designed to be small and used as part of a white stick.

**Akhilesh Krishnan et al., [2016],** Assistant, an intelligent walking stick, helps the visually impaired to identify obstacles and provide assistance to reach their destination. The assistant works on the basis of echolocation technology, image processing and navigation system. An assistant can be a possible help for the visually impaired and thus improve their quality of life. Much work and research is being done to find ways to improve the lives of the visually impaired. There are a number of walking sticks and systems that help the user move indoors and outdoors, but none of them offer autonomous navigation while driving, object detection, and alarm detection. Assist uses ultrasonic sensors to echo sound waves and detect objects. The image sensor is used to identify and navigate objects in front of the user by taking pictures while driving, and the smartphone application navigates the user to the destination using GPS (Global Positioning System) and maps.

#### **METHODOLOGY:**

We hereby propose a smart blind stick that allows visually challenged people to navigate with comfort using the advanced technology. An ultrasonic sensor and a water sensor are integrated into the roller blind. Our project first uses ultrasonic sensors to detect obstacles ahead using ultrasonic waves. When obstacles are detected, the sensor transmits this information to the Arduino Uno. Arduino uno processes the data and calculates if the obstacle is close enough. The circuit is ineffective if the impediment is not immediately present. If an obstacle is near the arduino, the Uno will send a warning in the form of a voice. It also detects water and warns the blind person with a different sound signal and gives it. The wand also contains a vibration sensor. If there is an obstacle nearby, the Arduino uno will send a vibration alert. Water is detected by a water sensor. Another feature is that it allows a blind person to detect whether there is light or darkness in a room. An advanced feature has been integrated into the system to help blind people find their cane if they forget where they kept it. A wireless RF based remote is used to find misplaced stick.

#### **PROPOSED METHOD**

The blind stick is an innovative cane designed to improve navigation for the visually impaired. Here we come up with an advanced blind stick that allows the visually impaired to navigate easily with advanced technology. An ultrasonic sensor and a fire and water sensor are integrated into the roller blind. The first stage of our proposed project involves the usage of ultrasonic sensors to detect imminent impediments using ultrasonic waves. When obstacles are detected, the sensor transmits this information to the microcontroller. The microcontroller then processes this information and calculates whether the obstacle is close enough. If the obstruction is not immediately visible, the circuit has no effect. If there is an obstacle nearby, the microcontroller will sound. It also detects water and alerts

the blind and sounds a second alarm. It is inserted as part of a complete device, which often includes hardware and mechanical parts.

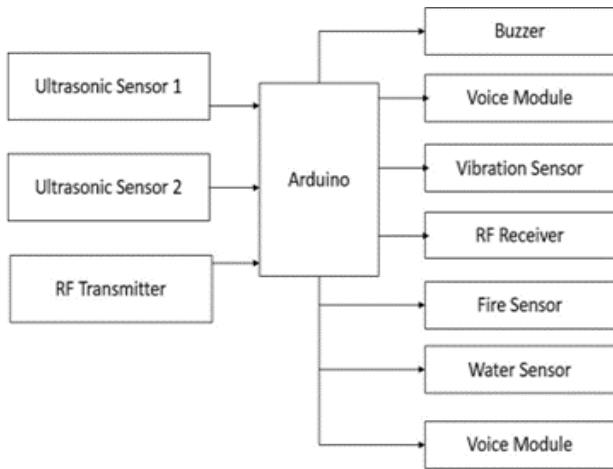

FIG.2.Block diagram

A.OBSTACLE DETECTION PROCESS

Obstacle detection process Tulo consists of an ultrasonic sensor that can detect obstacles in front of it from a distance of up to 70 cm. It is connected to the Arduino to detect if the resistance is too close to the stick and trigger an output if it is. The output consists of a vibration motor for haptic feedback and a piezo summation for auditory feedback. A block diagram of obstacle detection with feedback is shown in Figure 2. There are two detection systems in this process; one is an above-the-knee obstacle detection system where an ultrasonic sensor is placed on a stick approximately 80 cm from the ground. And the other is the below-the-knee obstacle detection system, where an ultrasonic sensor is placed on a stick about 15 cm above the ground. It detects obstacles at least 20 cm high.

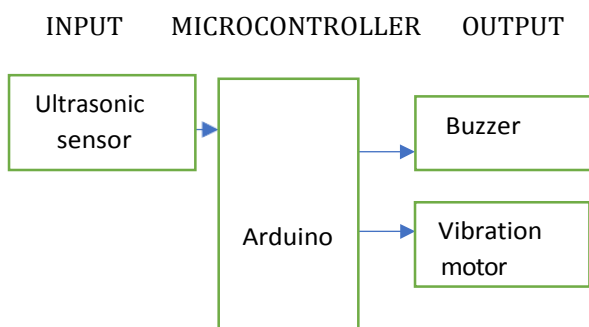

Fig.3: Obstacle Detection with Feedback

B. WATER DETECTION PROCESS

A raindrop sensor is placed at the bottom of the rod to detect water or mud. When the sensor detects water, it alerts the user with tactile and audible feedback. Soil moisture

sensors calculated volumetric water content using some other soil property, such as electrical resistivity, dielectric constant, or interaction with neutrons, as a proxy for moisture content. It is necessary to calibrate the link between the observed parameters and soil moisture because it can change based on the environment, including the soil, temperature, and electrical conductivity.



Fig.4: Water detection

C. RF REMOTE

The receiver section of the RF remote, which also includes a buzzer and a vibration motor, will help the user locate the stick if they misplace it. As opposed to infrared communication, which requires a line of sight link between the transmitter and receiver, radio frequency communication has various advantages. Compared to IR communication, RF communication has a much wider range. Here, RF modules (RF Transmitter and RF Receiver) are used to create a wireless transmitter and receiver system. The image of the RF transmitter is depicted in Fig. 4. Two little circuits are needed for this. The blind stick will have the receiver circuit attached to it. The other is a remote RF transmitter circuit that will be utilised to transmit signals in order to find the stick. The 433 MHz radio frequency signals used for wireless data transmission are modified using the Amplitude Shift Keying Modulation technique. To implement the transmitter and receiver functions, we employ an encoder (IC HT12E) and a decoder (IC HT12D).

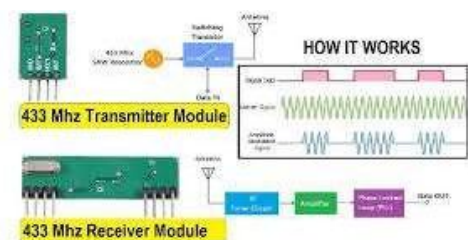

Fig.5: RF module

D.VOICE MODULE

The device works well in both indoor and outdoor settings. Natural Language Processing methods can be

used to translate the text that can be derived from the image into speech. The user receives audio notifications and vibrations that provide information about barriers. This module assists in warning visually challenged people of impending dangers.

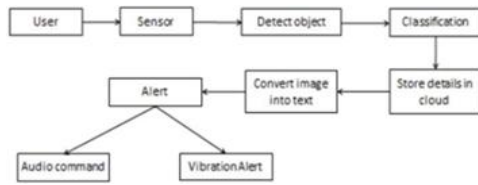

Fig 6.Voice Module Synthesis

APR9600 VOICE MODULE:

An affordable, high-performance sound record/replay IC using flash analogue storage is called APR9600. Even when the module's power supply is removed, the recorded sound is still there. Replayed audio displays excellent quality and little background noise. A 60-second recording time requires a sample rate of 4.2 kHz, giving a sound record/replay bandwidth of 20 Hz to 2.1 kHz. However, a sampling rate as high as 8.0 kHz can be attained by altering an oscillation resistor. The sound recording is now only 32 seconds long overall. By altering the value of a single resistor, the duration of the entire sound recording can be changed from 32 seconds to 60 seconds. The IC can function in either parallel mode or serial mode. Sound can be captured in 256 parts in serial access mode. Sound can be captured in 2, 4, or 8 portions in parallel access mode. Push-button keys are a simple way to control the IC. Moreover, external digital circuitry like computers and microcontrollers can be used to control the IC. With a 28-pin DIP package, the APR9600. 4.5 to 6.5 volts are the range of the supply voltage. The current consumption during recording and replaying is 25 mA. The current lowers to 1 Ma in standby mode.



Fig.7.Apr9600 voice module

E.PIR SENSOR

PIR sensors can identify movement from people or animals. Infrared energy is produced by humans. The PIR sensor detects these variations in radiation when a human enters its sensing range, which causes the sensor's output to increase. An electrical sensor that detects infrared light emitted by objects is known as a passive infrared sensor. PIR-based

motion detectors are the main applications for PIR sensors. Moreover, it is utilised in automatic lighting and security alarm systems. The PIR sensor's usual pin arrangement is shown in the image below. It is easy to grasp the pinouts. On the PIR sensor, there are three pins.

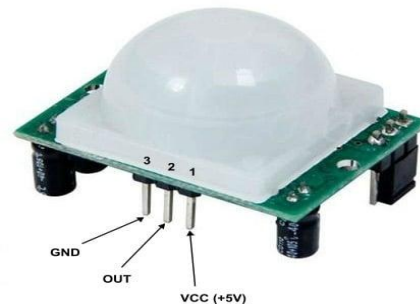

Fig.8.PIR sensor

- The drain terminal of the device, which is coupled to the positive supply of 5V DC, is represented by Pin1.
- Pin 2 is the device's source terminal, which is connected to the ground terminal by a resistor of either 100K or 47K. The sensor's output pin is Pin 2.
- The sensor's pin 3 is connected to ground, and pin 2 sends the detected IR signal to an amplifier.

The PIR sensor's range:

- Passive infrared detection ranges from 25 cm to 20 m indoors.
- The detection range for indoor curtain types is 25 cm to 20 m.
- The detection range for outdoor passive infrared sensors is 10 to 150 metres.
- Outdoor passive infrared curtain detector: 10 to 150 metres away

SENSORS WITH ORIENTATION

The offered stick uses the Ultrasonic Sensor HC SR-04 to identify potholes and obstacles. A sensor that uses sound waves to estimate distance from an item in front of it is called an ultrasonic sensor. By sending out a sound wave at a frequency of 40 Hz and listening for the equivalent stream to bounce back, it can calculate distance. The distance between the ultrasonic sensor and the obstruction can be calculated by keeping track of the amount of time that passes between the sound wave being emitted and the wave returning. As wind moves at a speed of 344 metres per second and it is thought that sound waves travel through air, we may calculate the time it will take the wave to return and multiply it by To determine

the total distance the sound wave travelled, multiply by 344. The lesson to be learned from this is that the wave travelled twice as far to the obstacle as it did to the ultrasonic sensor, thus we must divide the total length by two to get the distance from the obstruction. The fundamental operation of the ultrasonic sensor is shown

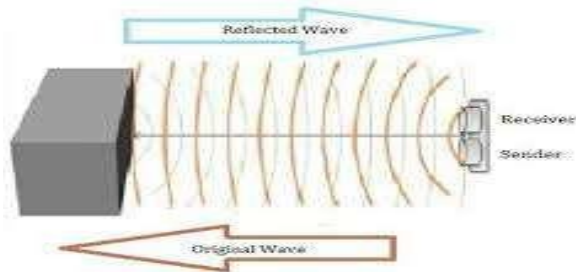

Fig.9: Ultrasonic Sensor

The non-contact range of the HC-SR04 ultrasonic sensor module is 2 cm to 400 cm. The control circuit, an ultrasonic receiver, and transmitters make up the module. The fundamental working tenets are as follows: (1) An IO trigger is used for a signal that is at least ten microseconds high; and (2) An ultrasonic sensor module repeatedly sends eight 40 kHz waves and detects if a signal is received in response. (3) The time between sending a wave and receiving it back is the time of high output IO duration if the signal is returned at a high level.

$$\text{Distance} = (\text{high-level time} * \text{speed of sound in air}(344\text{m/s}))/2.$$

**SPECIFICATION:**

COMPONENT	WORKING CURRENT	WORKING VOLTAGE	RANGE
ULTRASONIC SENSOR (HC SR04)	15mA	3.5V-5V	2cm-450cm
RF MODULE	3.5mA	3V-6V	300m
BUZZER	<=32mA	4V-8V	10cm(85dB)
VIBRATION SENSOR SW-420	11.9mA	3V-5V	
FIRE SENSOR	20mA	3V-5V	760nm-1100nm
WATER SENSOR	<20mA	3V-5V	40mm*16mm
ARDUINO	20mA-40mA	5V	

Table 2:Specification

**A. ULTRASONIC SENSORS VS IR SENSOR**

The application for which we intend to use the sensor will determine the sensor we choose. Infrared sensors have some limitations, such as the inability to feel and detect obstructions in daylight as a result of incursion. Applications in the outside world or in the shadows inside might become very troublesome when using IR sensors. Ultrasonic sensors use sound waves to function, therefore there are fewer things that can affect how well they can detect obstructions. Additionally, in our form, the stick

must function properly in both indoor and outdoor settings, as well as in both light and darkness, making the ultrasonic sensor the ideal choice for our application. Ultrasonic sensors have several advantages over camera, IR, and PIR sensors: a) Unlike a camera, which struggles to capture crisp images at night and whose IR sensors are affected by sunlight, it has a detecting capability that is independent of light; it will function as well in both daylight and darkness. b) It is not sensitive to outside influences like light, dust, smoke, vapour, etc. c) It can work better with certain types of obstacles, such as sponges, wood, plastic, tiles, etc.

Parameter	HC SR - 04	HY SRF - 05
Working Voltage	3.3 to 5 Volt	5 Volt
Static Current	< 2mA	< 2mA
Sensor Angle	<15 degrees	<15degrees
Detection Distance	2cm to 4m	2cm to 4m
Pin Number	4	5
Pins	VCC, trig, echo, GND	VCC, trig, echo, GND, OUT
Precision	3mm	2mm

Table 1:Comparison between sensors

**RESULTS AND DISCUSSION**

In the beginning of this project, ultrasonic sensors are used to look for impending obstructions. The sensor transmits this information to the microcontroller when it detects impediments. This information is then processed by the microcontroller, which determines whether the impediment is close enough. If the obstruction is not immediately present, the circuit has no effect. The microcontroller sends a signal to the buzzer to sound if the obstruction is closed. Moreover, it detects water and informs the blind by sounding a distinct buzzer. It is included into a whole device, frequently with physical and mechanical components. Several commonly used gadgets are controlled by embedded systems. 98 percent of all microprocessors produced today are embedded system components. Low cost per unit, small size, tough working ranges, and low power consumption compare favourably with general-purpose competitors. This comes at the expense of having less processing resources, which makes programming and interacting with them much more challenging. However, by adding intelligence mechanisms on top of the hardware, making use of any already-existing sensors, and having a network of embedded units, it is possible to manage resources at the unit and network levels optimally while also offering augmented functionalities that go far beyond what is currently offered.

**CONCLUSION**

In this paper, A smart assistive gadget is made to make it safer for blind or visually impaired persons to

manoeuvre around holes, water, stairs, and other challenges they encounter on a regular basis. They can use the established solution as an easy-to-use directional guide. The system's advantage is that it may prove to be a cheap option for millions of visually impaired people around the world. It offers tactile and audible feedback for both knees below and knees above obstacle detection. Obstacles with a height of at least 20 cm can be detected by it. From a distance of 70 cm, it can detect stairs and other obstructions. Another benefit is that if someone forgets or drops a stick, they may still find it by pressing the transmitter's switch from a distance of roughly 300 metres away. It has a 30 cm pothole detection range, which is one of its limits, and using it requires training for the user.

## FUTURE WORK

Our future work will mainly focus on the enhancement of object recognition so that it can detect and identify objects better in challenging environmental conditions. Additionally, improving the charge capacity of the device will be included. Object identification will be improved by adding more image databases. Better algorithms could be added for the device to navigate using dynamic image recognition

## REFERENCES

1. "A smart walking stick for visually challenged using Raspberry Pi," Sriram Engineering College, International Journal of Pure and Applied Mathematics, volume 119 no. 16, 2018, 3485–3489, 2018.
2. Muhammad Luqman Azzaki and Rashidah Funke Olanrewaju Mohd Radzi, Mariam Rehab, "iWalk: intelligent walking stick for visually impaired people", Proc. of the 4th IEEE International conference on smart instrumentation measurement and applications (ICSIMA) Putrajaya, Malaysia, 28-30 November 2017.
3. Gu-Yang Liu, Yi-Qing Liu, Zhi-Kai Gao, and Zhang-Jian Shao ECAI 2017- International Conference, 9th Edition, electronics, computers, and artificial Intelligence, Targoviste, Romania, 29 June – 1 July 2017, "Intelligent Ultrasonic Detection of Walking Sticks for the Blind".
4. "Effective rapid reaction smart stick for blind people," conference paper, Ayat Nada, Ahmed Farag Seddik, and Mahmoud Fakhr, April 2015.
5. "Blind help," Chris Urquhart and Nathaniel Sims, Electrical and Computer Engineering Department, Howard University, April 25, 2012.
6. "Assistive voice alert based smart stick for blind persons with GPS," International journal of engineering trends and applications (IJETA), volume 5 issue 2, Nellore, India, March–April 2018. S. Munirathnam, professor; S. Amrutha Valli, undergraduate student
7. Received: 14 January 2018; accepted: 8 March 2018; published: 13 March 2018. Department of Computer Techniques Engineering, Al- Kafeel University College, Kufa 31003, Province of Najaf, Republic of Iraq.
8. "Simple smartphone-based guidance system for visually impaired people," by Cheng-Che Lee, Pei-Ying Chiang, Academic editor: Antonio Jimenez, National Taipei University, Taipei, Taiwan. 23 April 2017: submission; 9 June 2017: acceptance; 13 June 2017: publication
9. Mr. Praveen Olekar, "Integrated smart shoe for blind people," SIET, Tumkuru, 2015–2016, project reference no. 39S BE 0939.
10. Ashraf Anwar, "A smart stick for assisting blind people," Sultan Aljahdali Volume 19, Issue 3, Version II (May-June 2017), Pages 86–90, IOSR Journal of Computer Engineering (IOSR-JCE).
11. M.S. Godwin Premi, Anshu Raj, and Ankit Kumar, "Blind aid stick with an alarm system utilising image processing," International Journal of Pure and Applied Mathematics, department of ETCE, Satyabhama Institute of Science and Technology, Volume 118 no.24, May 21, 2018.
12. Pooja Sharma and Mrs. S. L. Shimimi, "Design and development of virtual eye for the blind", Chandigarh, International journal of creative research in electrical, electronics, instrumentation, and control engineering, Vol. 3, number 3, March 2015.
13. "The third eye for the blind utilising Arduino and ultrasonic sensor," M. Narendran, S. Padhi, and A. Tiwari. National Journal of Interdisciplinary Research and Development, Department of Computer Science & Engineering, SRM Institute of Science & Technology Ramapuram, Chennai, Tamil Nadu, India ISSN: 2455-9040 Impact Factor: January 2018, Volume 3, Issue 1, Pages 752-756.
14. "Smart walking stick for the blind person" by Sathya, S. Nithyaroop, P. Betty, G. Santoshni, S. Sabharinath, and M. J. Ahana. Kumara Guru College of Technology Coimbatore, Department of Computer Science and Engineering. Issue 118 No. 20, 2018, Coimbatore International Journal of Pure and Applied Mathematics
15. "Smart walking stick for visually challenged individuals," by Jayakumar, S. Magesh, K. Prasanth, P. Umamaheswari, and R. Senthilkumar. Erode Sengunthar Engineering College, Department. of EEE. International. IJARBEST Volume 3, Special Issue 24, March 2017. Journal of Advanced Research in Basic Engineering Sciences and Technology (IJARBEST)

16. Adebimpe Lateef, Dada Emmanuel, Gbenga, Arhyel, Ibrahim Shani, and Adekunle. "Smart walking stick for blind persons utilising Arduino and ultrasonic sensor." University of Maiduguri in Borno State, Nigeria, has a department of computer engineering. Vol. 4, Issue 3, March 2016, International Journal of Innovative Research in Electrical, Electronics, Instrumentation, and Control Engineering
17. "Ultrasonic and voice-based smart sticks," by D. Sekar, S. Shivakumar, P. Thiyagarajan, R. Premkumar, and Vivekkumar. Engineering college in SriEshwar. Vol. 4, Issue 3, March 2016, International Journal Of Innovative Research In Electrical, Electronics, Instrumentation, And Control Engineering
18. Abdel IlahNour Alshbatat. For partially or completely blind people, an automated mobility and orientation system. SMART SENSING AND INTELLIGENT SYSTEMS INTERNATIONAL JOURNAL, 568-582, 2013.
19. Mrunmayi Mohan Modak, Varun Vasant Marathe, and Harshad Girish Lele. "Electronic path guidance for those with visual impairments." 2013-09-14, International Journal Of Engineering And Science (IJES).Al-Mosawi Ali I., Muhsin Asaad H., and Mahdi Safaa A.
20. "Using Ultrasonic Sensor Combines Voice for Blind and Deaf Persons." Association for the World Science Conference, 2012, pp. 50-52.
21. Yassine Salih-Alj, Sara Lhaddad, Yasmine Taybi, and Lamy El Alamy. "Bus Identification System for Persons with Vision Impairments." 2012 International Conference on Next Generation Mobile Apps, Services, and Technology, pages 13-17.
22. "Electronic long cane for mobility enhancing on vision impaired persons," A. R. Garcia, R. Fonseca, and A. Duran. IEEE, 2011, pp. 58-61.
23. "BLI - NAV Embedded Navigation System for Blind Persons," by S. Sai Santhosh, T. Sasiprabha, and R. Jeberson. IEEE, 277-282, 2010.
24. Roslina M. Sidek, Ariffin A., Herdawatie A. Kadir, MohdHelmyAbdWahab, Amirul A. Talib, AyobJohari, and A. Noraziah IJCSI, Vol. 8, No. 4, July 2011, "Smart Cane: Assistive Cane for Visually Impaired People."
25. <http://www.who.int/topics/blindness/en/index.html> [9]. 978-1-4244-7562-9/10, "Electronic Interfaces Aiding the Visually Impaired in Environmental Access, Mobility, and Navigation."
26. 4816.0.55.001 - Occasional Paper: Long-term Health Problems - A Guide To Time Series Comparability From The National Health Survey, Australia, 2001.
27. <https://www.who.int/en/news-room/fact-sheets/detail/blindness-and-visual-impairment> (abs.gov.au)
28. Johann Borenstein and Yoram Koren, "The Guide Cane - A computerised Travel aid for the Active Guiding for the Blind Pedestrians," in Proceedings of the IEEE international conference on Robotics and Automation, Albuquerque, April 1997.
29. Johann Borenstein, Shraga Shoal, and Iwan Ulrich, "Navelbelt and Guidecane," IEEE Robotics and Automation Magazine, Special Issue on Robotics in Bio-Engineering, Volume 10, No. 1, March 2003, pp. 9-20.
30. "Smart walking stick - an electronic technique to assist visually impaired folks," Mohammad Hazzaz Mahmud, Rana Saha, and Sayemul Islam, International Journal of Science & Engineering Research, Volume 4, Issue 10, October-2013.