

Evaluation and Mechanical Properties of Kevlar S-Glass and Carbon Fiber with Graphite Powder Using Hand Layup Technique

Suthar Venkatesh¹, B. Purna Chandra Sekhar², Dr. R. Vijaya Prakash³, P. Narendra Mohan⁴

¹PG scholar, Department of Mechanical Engineering, Acharya Nagarjuna University, A.P, India.

^{2,3,4}Asst. Professor, Department of Mechanical Engineering, Acharya Nagarjuna University, A.P, India.

Abstract - Composite materials are made of two or more constituent materials that are combined to create a material with superior properties to those of the individual materials. Synthetic fibers, such as glass fiber, carbon fiber, and aramid fiber, are often used as the reinforcing material in composite materials. These fibers are strong, lightweight, and have good fatigue resistance. The matrix material, which surrounds the fibers, is typically an epoxy resin or a thermoplastic. The matrix material provides the composite with its toughness and durability. Composite materials are used in a wide variety of applications, including automotive, aerospace, marine, and sporting goods. In the automotive industry, composite materials are used to make lightweight components, such as bumpers, spoilers, and door panels. They are also used to make structural components, such as the hood and trunk lid. The aim of this project is to fabricate and test seven different combinations of composite materials for use automobile bumpers. The materials that will be used are Kevlar, S glass, carbon fiber, and graphite powder. The composites will be fabricated using the hand layup technique. The tensile strength, flexural strength, impact strength, and hardness of each composite will be tested. The results of the tests will be used to determine which composite is the best for use in automobile bumpers. The car bumper will be designed using the CATIA software and analyzed using the ANSYS software. The von-Mises stress and total deformation of the bumper will be calculated for each material. The results of the analysis will be used to verify the findings of the experimental tests. This project will provide valuable information on the use of composite materials in automobile bumpers. The results of the project will help engineers to select the best composite material for specific applications.

Key Words: Kevlar, S-Glass, Carbon Fiber, 10% Graphite Powder, Fabrication, Testing, ASTM.

1. INTRODUCTION

Composite materials are a class of materials that are made up of two or more constituent materials with significantly different physical or chemical properties. The individual materials, called the reinforcement and the matrix, are combined to produce a material with properties that are superior to those of the individual materials. The reinforcement is the material that provides the strength and stiffness to the composite. It is typically made of fibers, such as glass fibers, carbon fibers, or aramid fibers. The matrix is the material that binds the fibers together and provides the composite with its toughness and durability. It is typically made of a polymer resin, such as epoxy or polyester.

Composite materials are used in a wide variety of applications, including:

- Aerospace: Composite materials are used in aircraft structures, such as wings, fuselages, and tail fins. They are also used in helicopter blades and rocket bodies.
- Automotive: Composite materials are used in car bodies, bumpers, and other components. They are also used in racing cars and Formula One cars.
- Marine: Composite materials are used in boat hulls, sails, and fishing rods. They are also used in offshore oil platforms and wind turbines.
- Sporting goods: Composite materials are used in golf clubs, tennis rackets, and fishing rods. They are also used in protective gear, such as helmets and body armor.
- Construction: Composite materials are used in bridges, buildings, and other structures. They are also used in pipes and other infrastructure.

Despite these concerns, synthetic fibers are a valuable resource that are used in a wide variety of applications. As scientists develop more sustainable methods for producing synthetic fibers, their use is likely to continue to grow.

1.1 Composite

"Composite" refers to the physical mixture of two or more separate materials. When two constituent materials having diverse mechanical, physical, and chemical properties are joined, a composite material with different characteristics than the individual material is generated. The two elements are reinforcement and matrix. The reinforcement and matrix are the primary load-carrying elements in a composite material.

Composites can be classified by the type of reinforcement material or the type of matrix material. Common reinforcement materials include fibers, particles, and flakes. Common matrix materials include plastics, metals, and ceramics. Fiber-reinforced composites are gaining interest in a variety of applications due to their high strength-to-weight ratio and stiffness. However, their growth is limited by their low toughness. Toughness is a material's ability to absorb energy and resist fracture.



Figure - 1: Nylon Figure - 2: Acrylic



Figure - 3: Acetate Figure - 4: Polyester

1.1.1 Physical and chemical properties of composites

- Excessive particular stiffness and strength.
- Dimensional stability.
- Chemical and heat resistant.
- Relatively straightforward to handle.
- It has a light weight.
- Outstanding strength-to-weight ratio.
- Excellent anticorrosion properties.

Some of the properties of composite materials are exhaust life, electrical protection, wear resistance, warm protection quality, light weight, solidness, warm conductivity, fire resistance, temperature-subordinate conduct, and warm protection. Composite materials have a lengthy history of application. These composite materials are renewable and biodegradable. Composite materials offer a high fatigue resistance when compared to other metals. When compared to other materials, composites offer minimal radar visibility and are easier to form into complex shapes. Composite materials are frequently employed in surface transportation due to their great size. Composite materials can be used effectively in surface transportation because they have a greater strength-weight ratio than conventional materials. The two most important characteristics of a good composite material are robustness and productivity.

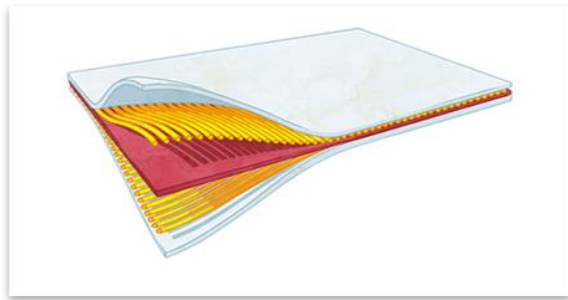

Figure - 5: General formation of a composite

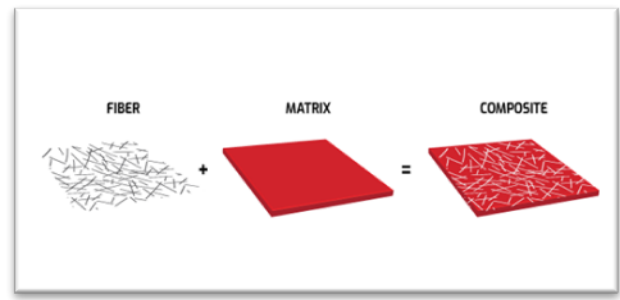

Figure - 6: Composite materials

1.1.2 Advantages of composites

- They can be made to be very strong or very light, depending on the application.
- They are often corrosion-resistant and have good thermal and electrical properties.
- They can be made in a variety of shapes and sizes.
- They are relatively easy to fabricate.

1.2 Composites on transportation sector

The imminent advantages stemming from reduced weight, enhanced durability, and superior resistance to corrosion firmly establish advanced composites as the material of choice for upcoming automotive applications. However, realizing their full potential for widespread integration into cars and trucks necessitates substantial transformations across a wide spectrum. The most prominent hindrance remains the comparably high cost of both the raw materials and the finished composites, in contrast to the existing alternatives. Nevertheless, specific windows of opportunity open up for advanced composites within distinct components of the commercial automotive industry.

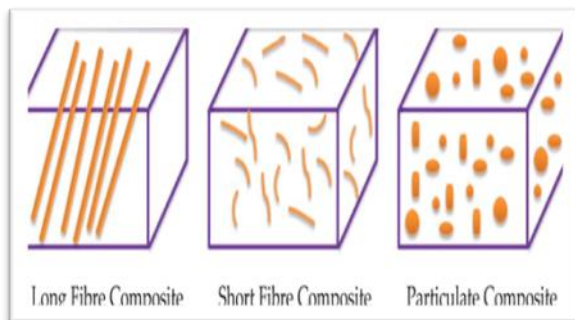

Figure - 9: Various types of composite structures

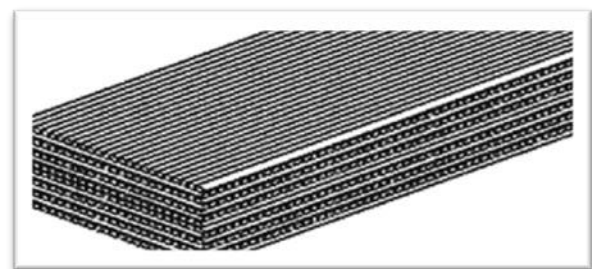

Figure - 10: Polymer matrix composites

In the realm of specialty vehicles, particularly those crafted in limited quantities, advanced composite materials possess a unique chance to showcase their performance merits, surpassing the demands set by the competitive market environment. While prevailing challenges must be addressed to achieve broader adoption, these niche sectors pave the way for advanced composites to vividly demonstrate their value proposition.

1.3 Classification of composites

Composite materials are categorized using two distinct classification systems. The first classification hinges on the nature of the matrix material, which can be metal, ceramic, or polymer. The second system revolves around the structure of the reinforcing material.



Figure - 7: Composites in transport sector example

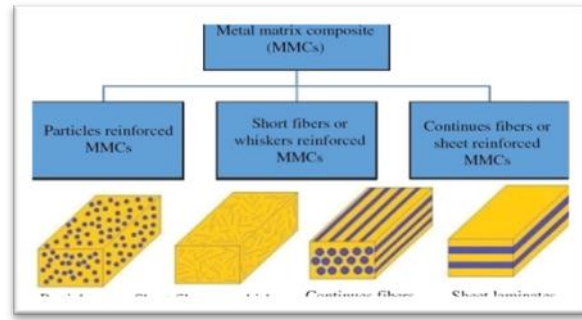

Figure - 8: Classifications of metal matrix composites

1.3.1 Metal Matrix Composite (MMC)

A metal matrix composite (MMC) is an intricate material blends comprising of a minimum of two constituents. One of these constituents must unequivocally be a metal, while the second component can encompass alternative metal or divergent materials like ceramics or organic compounds. In cases where three or more materials coexist, this amalgam is referred to as a hybrid composite.

Metal Matrix Composites, or MMCs, are meticulously crafted by interweaving a metallic matrix, which can encompass metals such as aluminium, magnesium, iron, cobalt, or copper, with a dispersed phase. This secondary phase could manifest as a ceramic component, featuring oxides or carbides, or even a metallic phase, incorporating elements like lead, tungsten, or molybdenum. This intricate interplay of materials endows MMCS with their distinctive properties and applications.

1.3.2 Polymer matrix composite (PMC)

A polymer matrix composite (PMC) emerges as a composite material intricately composed of an array of either short or continuous fibers, artfully intertwined within an organic polymer matrix. The primary purpose of PMCs revolves around the seamless transfer of loads between the fibers and the matrix, crafting a material that excels in structural integrity.

1.4 Natural fiber reinforced composites (NFRC)

Natural Fiber Reinforced Composites, harnessed from an assortment of natural fibers like Carbon fiber, Jute, hemp, sisal, pineapple, Agave Americana, bamboo, okra, and coir, epitomize a remarkable synergy between eco-consciousness and innovation. These fibers, resembling hair-like strands or fragments, are not only bountiful but also exceptionally cost-effective, making their integration a sustainable choice.

1.5 Industrial applications of fiber reinforced composites materials:

(a) Military and aerospace applications



Figure - 11: Light weight natural composites military Helmet



Figure - 12: Bio composite cabin in car door

Moreover, the dynamic impact of fiber-reinforced epoxies reverberates in rotor blades that adorn both military and commercial helicopters. In the domain of rocket structures, these materials have emerged as frontrunners, adept at curbing weight and consequently extending rocket range while bolstering payload capacity. The steady progression of fiber-reinforced composites has etched a substantial imprint, elevating the performance and efficiency benchmarks of both military and commercial aircraft. Today, these materials have not only ingrained themselves as integral components but have also become the bedrock of aerospace innovation.

Within spacecraft design, the integration of fiber-reinforced composites holds a pivotal role across a multitude of applications, driven by their exceptional properties. This diverse spectrum includes the incorporation of boron fiber-reinforced aluminum tubes to fortify mid-fuselage bracket structures, a harmonious fusion of aluminum honeycomb and Carbon fiber-reinforced epoxy face sheets for the payload delta entryway, the strategic deployment of long super high modulus Carbon fiber-reinforced epoxy tubes to empower remote control arms, and the crafting of robust vessels from Kevlar 49 fiber-reinforced epoxy to manage weight with efficacy.

hoods, fans, and pipes, and extends even further. Polyester composites, endowed with innate halogenated flame-retardant properties, render safe havens for critical structures like fuel tanks, chimneys, hoods, fans, and pipes, ensuring heightened fire safety without compromising on durability or cost-effectiveness. The harmonious amalgamation of modacrylic polyester and polypropylene fibers emerges as the bedrock for acid neutralizers, hailed for their impeccable abrasion and chemical resistance. In this vibrant tapestry, even natural fibers such as jute make their mark, adorning specific applications with their inherent cost-effectiveness and admirable attributes. The meticulous orchestration of diverse materials encapsulates not only the versatility of composites but also their strategic alignment with industry-specific demands, yielding an innovative landscape that marries performance and sustainability.

(b) Building industry

The construction industry has been profoundly reshaped by the emergence of composite materials, casting its influence across various facets. Notably, these materials have made remarkable strides in the creation of integral components like corrugated sheets, windows, pools, cladding panels, and exterior walls, unfurling an era marked by innovative design and structural excellence.



Figure - 13: Concrete Fiber Reinforced Polymer Composite



Figure - 14: Fiber Reinforced Composite Surfboards



Figure - 15: Plant resins

1.6 Resins

Within the realm of polymer science and materials science, the term "resin" signifies a substance with a viscous or solid nature, sourced either from plants or synthetically crafted, possessing the remarkable potential to metamorphose into polymers. Resins, in their essence, encapsulate intricate compositions of organic compounds, emblematic of the complexity inherent in the world of polymer chemistry.

A prime illustration of this transformative capability is BISPHENOL A DIGLYCIDYL ether, a resin that seamlessly evolves into epoxy adhesive upon the introduction of a hardener. This metamorphosis underscores the dynamic nature of synthetic resins, adapting to meet specific needs and challenges. Equally noteworthy are the versatile applications of silicone materials, rooted in silicone resins and brought to life through the alchemical process of room temperature vulcanization.

This intricate journey of transformation from resin to functional material epitomizes the intersection of science and innovation.

2. LITERATURE REVIEW

- 1) In this study, Mohammed Hisham, Mohammed Fahaduddin, Mohammed Azhar Khan, Ashok B C, and Prashant Kumar Shrivastava delve into an exploration of diverse hybridization methods and treatments aimed at enhancing the mechanical properties of Kevlar composites. The research aims to uncover ways to elevate the strength and performance of these materials through innovative approaches.
- 2) Tidong Zhao, Jing Yang, Jinxiang Chen, and Sujun Guan investigate the bending and compressive mechanical attributes of sandwich structures featuring distinct core layers. Their work highlights the advancements, ongoing challenges, and future prospects within the realm of this research. Their findings underscore a significant reduction in load-bearing capacity caused by certain phenomena in truss-core sandwich structures. Additionally, these structures exhibit swift attainment of ultimate load-bearing capacity post-initial buckling, indicating limitations in energy absorption performance.
- 3) The team of Manjunath Pattan, Bipin J, Sudarshan Shetty, and Sajjan S.C sheds light on a simplified method for manufacturing composite materials, distinguishing it from conventional techniques. A noteworthy outcome of their investigation is the inverse relationship between Kevlar and epoxy percentages, leading to cost reductions in specimen production. By augmenting the Kevlar-to-jute ratio, the study reveals amplified tensile, compressive, and bending strengths, alongside heightened flexural strength and decreased specimen weight. Notably, the research underscores the importance of composite thickness in bolstering tensile strength for applications subject to dynamic loading.
- 4) A collaborative effort by Mohamad Barkat Ibrahim, Hussein Yousef Habib, and Rafi Mousa Jabrah culminated in the preparation of hybrid composite materials using Kevlar-49 fabric, E-Glass fabric, and epoxy. The mechanical characterization of these materials revealed a fascinating pattern: the resulting Kevlar/glass/epoxy hybrid composites consistently displayed mechanical properties that bridged the gap between Kevlar/epoxy and glass/epoxy composites. This intriguing observation suggests the possibility of creating a diverse range of composite materials with tailored mechanical attributes, carefully balancing considerations of performance and economics.
- 5) Jones and colleagues embarked on an exploration of hybrid micro-composites, a composite system encompassing around nine single fibers in Epon 828/Versamid 140. In their study, a combination of E-glass, AS-4, IM6-G carbon, and Kevlar-49 fibers was employed. Notably, the research deduced that the AS4/Kevlar-49 hybrid system exhibited the least coordinated fracture. Drawing from a computer model centered around the hybrid effect and the principle of local load sharing, the study proposed an enhancement in the strength of stiffer fibers within the hybrid composite. This model's insights resonated with findings from other authors' experiments, as elaborated in their comprehensive paper.
- 6) An inventive study by Ting-Ting and their team delved into the realm of materials engineering by employing Kevlar fabric, glass fabrics, and even repurposed Kevlar/Nylon/low-Tm polyester nonwovens through the utilization of needle-punching and thermal-bonding techniques. The remarkable outcome was an enhancement in both static and dynamic puncture resistances, attributed to the heightened cut resistance of Kevlar fibers and the augmented compactness of fiber assemblies. This innovative approach holds the promise of fortifying puncture resistance through thoughtful material selection and processing.

3. COMPOSITION OF SPECIMEN MATERIALS

In the diverse landscape of India, a wide array of indigenous plant species boasts a unique blend of regenerative qualities along with a notable fiber content. This intriguing assortment comprises both cultivated and wild varieties, including plants, creepers, and trees that thrive in forests and woodlands. Recognizing the inherent strength of fibrous structures over bulk materials, these resilient fibers are harnessed for various applications.

Notably, India is home to resources like Pineapple and Agave Americana, which have found utilization in their medicinal forms. However, the commercial potential of these fibers is yet to be fully explored in comparison to other fiber types. This study aims to delve into the promising prospect of incorporating these fibers into the creation of novel composite materials for load-bearing structures.

3.1 Materials

Among the diverse array of resins and hardeners available, Epoxy LY556 and hardener HY951 emerge as the selected duo for this exploration. The journey delves into the realm of materials, with Kevlar, Carbon fiber, S-GLASS, and Graphite powder taking the spotlight. These materials are deftly woven into various ratios and combinations, birthing six distinct composites that form the crux of investigation.

Intriguingly, the focus extends beyond mere formulation, encompassing a meticulous analysis of impact strength, tensile strength, and flexural strength across the spectrum of these composite variations. This multidimensional approach unveils the nuanced interplay between these components and offers a comprehensive understanding of their composite prowess.

3.1.1 Epoxy

Within this study's framework, the role of epoxy LY556 takes center stage as the chosen matrix material, depicted in Figure 3.1. This selection is a result of a meticulous assessment, positioning epoxy LY556 as a prime contender for crafting hybrid fiber epoxy composites. Renowned for its multifaceted attributes, epoxy LY556 stands out for its remarkable qualities, rendering it a favored choice.

Akin to a masterstroke, epoxy LY556 boasts an array of merits. Its reputation is built on a foundation of low shrinkage, elevated mechanical properties, simplified fabrication processes, and unwavering chemical and moisture resistance.

Notably, epoxy resins emerge as the epitome of thermo-set plastics within the polymer matrix composite domain. The characteristic trait of negligible reaction byproducts during curing affords them a unique distinction. This, in turn, ushers in a realm of low cure shrinkage, underscored by impeccable adhesion to diverse materials. Moreover, their innate resilience against chemical onslaughts and environmental forces, coupled with commendable insulating attributes, solidifies epoxy resins' stature as an unparalleled choice.



Figure - 16: Kevlar



Figure - 17: S glass fibers

4. FABRICATION OF COMPOSITE SPECIMENS

4.1 Hand layup technique

The hand lay-up technique stands as an uncomplicated and cost-effective approach in the realm of composite processing. Notably, this technique boasts minimal infrastructural prerequisites, further enhancing its appeal. To evaluate the mechanical properties of fiber-resin composites, the widely accepted ASTM-D790M-86 standard test procedure is employed, ensuring standardized measurements.

Measuring mass of Epoxy resin (2) Measuring mass of Hardener (3) Taking appropriate proportion of Epoxy resin and Hardener (4) Measuring mass of fibers (5) Pouring of mixer into the mold (6) Applying pressure on mold (7) layering with epoxy resins and powders (8) Marking on specimen.

4.2 Before testing specimens:

Prior to conducting tests on the following materials: Kevlar, S glass, carbon fiber, Kevlar + S glass, S glass + carbon fiber, Kevlar + carbon fiber, and Kevlar + S glass + carbon fiber, a 10% addition of Graphite powder is introduced into the specimens.

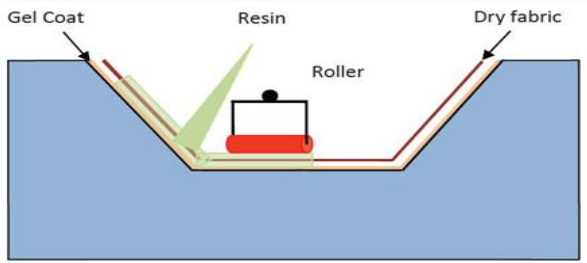

Figure - 18: Hand layup process



Figure - 19: Before cutting the specimen (curing period)



Figure - 20: Carbon Fiber

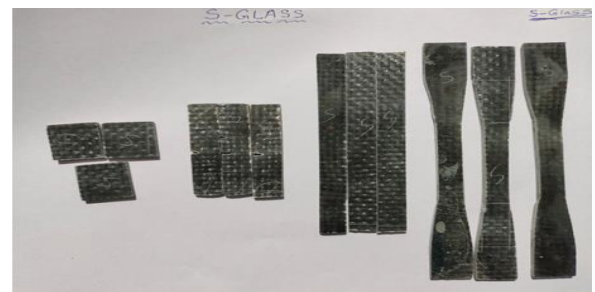

Figure - 21: S-Glass



Figure - 22: Kevlar



Figure - 23: Kevlar + Carbon Fiber



Figure - 24: Kevlar + S-Glass

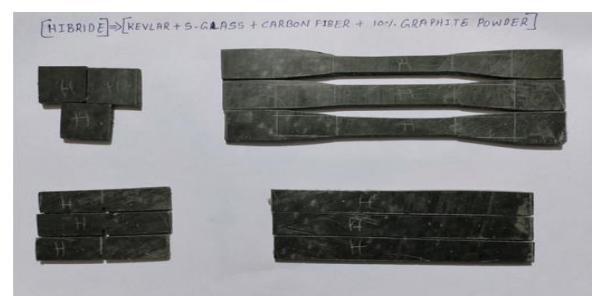

Figure - 25: Carbon + S Glass+ Kevlar with 10% Graphite Powder

5. RESULTS AND DISCUSSION

5.1 Mechanical characteristics of composites

The ensuing table, designated as Table.1, elucidates the properties of the hybrid epoxy composites reinforced with different fibers—Kevlar, Carbon fiber, S glass, Kevlar/Carbon fiber, Kevlar/Carbon fiber/S glass, Kevlar/S glass, and Carbon fiber/S glass. Each composite specimen was subjected to distinct tests as detailed in the preceding chapter. The comprehensive process of creating these composites and conducting the tests has been previously expounded upon

S.NO	COMPOSITE	TENSILE TEST(MPa)		FLEXURAL TEST(MPa)		IMPACT TEST	HARDNESS NUMBER
		LOAD(N)	ELONGATION(mm)	LOAD(N)	ELONGATION(mm)	(J)	
1	CARBON	8350	5.5	450	8.15	2.7	100.65
2	S GLASS	17400	7.2	520	6.6	3.7	62.41
3	KEVLAR	11375	6	335	7	1.9	94.95
4	KEVLAR/S GLASS	13805	6.35	480	6.35	3.2	59.51
5	KEVLAR/CARBON	9980	6.4	435	7.9	2.6	130
6	S GLASS/CARBON	15560	6.3	460	5.8	3.5	129.22
7	KEVLAR/S GLASS/CARBON	19100	5	495	4.4	4.9	159.15

Table - 1: Elucidates the properties of the hybrid epoxy composites reinforced with different fibers

5.2 Tensile Strength

The execution of fabrication and subsequent testing has been accomplished effectively within the scope of this project. The project focused on examining the tensile properties of various composite combinations, including Kevlar, Carbon fiber, S glass, Kevlar/Carbon fiber, Kevlar/Carbon fiber/S glass, Kevlar/S glass, and Carbon fiber/S glass. These composites were meticulously crafted using the hand lay-up method.

The evaluation of tensile strength was carried out through a carefully established relation.

$$\text{Tensile stress } \sigma_t = \frac{\text{tensile load}}{\text{area of cross-section}} = \frac{P}{A} \text{ N/mm}^2$$

$$\text{CARBON: } \sigma_t = \frac{8350}{200 \times 25} = 1.67 \text{ MPa}$$

$$\text{KEVLAR/CARBON: } \sigma_t = \frac{9980}{200 \times 25} = 1.99 \text{ MPa}$$

$$\text{S GLASS: } \sigma_t = \frac{17400}{200 \times 25} = 3.48 \text{ MPa}$$

$$\text{CARBON/S GLASS: } \sigma_t = \frac{15560}{200 \times 25} = 3.11 \text{ MPa}$$

$$\text{KEVLAR: } \sigma_t = \frac{11375}{200 \times 25} = 2.27 \text{ MPa}$$

$$\text{KEVLAR/CARBON /S GLASS:}$$

$$\sigma_t = \frac{19100}{200 \times 25} = 3.82 \text{ MPa}$$

$$\text{KEVLAR/ S GLASS: } \sigma_t = \frac{13805}{200 \times 25} = 2.76 \text{ MPa}$$

Following the successful completion of the tensile strength testing, the highest values were observed in the case of KEVLAR/CARBON FIBER/S GLASS composite, reaching a maximum of 19110 N.

Tensile test(Load vs Elongation)

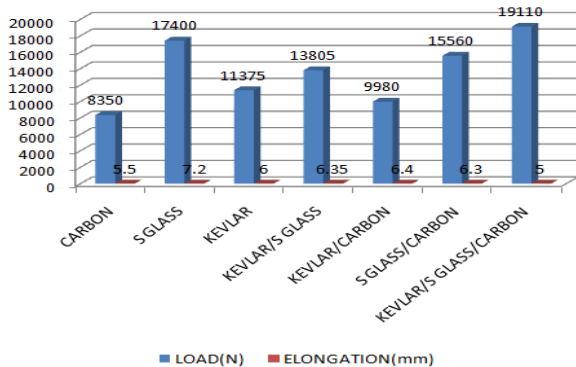

Graph - 1: Tensile test result graph



Figure - 26: Tensile strength materials specimens

5.3 Flexural Strength

The fabrication and testing phases of this project have been successfully concluded, focusing on the flexural strength analysis of various composites including Kevlar, Carbon fiber, S glass, Kevlar/Carbon fiber, Kevlar/Carbon fiber/S glass, Kevlar/S glass, and Carbon fiber/S glass. These composites were fabricated using the hand lay-up technique. The flexural strength was determined using the following relationship:

$$\text{Flexural strength } S = \frac{3 P L}{2 b t^2}$$

$$\text{CARBON: } S_1 = \frac{3 \times 450 \times 200}{2 \times 25 \times 4 \times 4} = 337.5 \text{ N/mm}^2$$

$$\text{S GLASS: } S_1 = \frac{3 \times 520 \times 200}{2 \times 25 \times 4 \times 4} = 390 \text{ N/mm}^2$$

$$\text{KEVLAR: } S_1 = \frac{3 \times 335 \times 200}{2 \times 25 \times 4 \times 4} = 251.2 \text{ N/mm}^2$$

$$\text{KEVLAR/SGLASS: } S_1 = \frac{3 \times 480 \times 200}{2 \times 25 \times 4 \times 4} = 360 \text{ N/mm}^2$$

$$\text{KEVLAR/CARBON:}$$

$$S_1 = \frac{3 \times 435 \times 200}{2 \times 25 \times 4 \times 4} = 326.2 \text{ N/mm}^2$$

$$\text{CARBON /S GLASS:}$$

$$S_1 = \frac{3 \times 460 \times 200}{2 \times 25 \times 4 \times 4} = 345 \text{ N/mm}^2$$

$$\text{KEVLAR/ CARBON FIBER/S GLASS:}$$

$$S_1 = \frac{3 \times 495 \times 200}{2 \times 25 \times 4 \times 4} = 371.25 \text{ N/mm}^2$$

The percentage of elongation is calculated by the follow equation,

$$\% \text{ elongation} = \frac{\text{change in length}}{\text{original length}} \times 100$$

$$\text{CARBON \% of elongation}$$

$$= \frac{8.15}{200} \times 100 = 4.07\%$$

$$\text{KEVLAR / S GLASS \% of elongation}$$

$$= \frac{6.35}{200} \times 100 = 3.17\%$$

$$\text{KEVLAR / CARBON \% of elongation}$$

$$= \frac{7.9}{200} \times 100 = 3.95\%$$

$$\text{S GLASS \% of elongation} = \frac{6.6}{200} \times 100 = 3.30\%$$

$$\text{KEVLAR \% of elongation} = \frac{7}{200} \times 100 = 3.50\%$$

$$\text{CARBON / S GLASS \% of elongation}$$

$$= \frac{5.8}{200} \times 100 = 2.90\%$$

$$\text{KEVLAR / CARBON FIBER / S GLASS \% of elongation}$$

$$= \frac{4.4}{200} \times 100 = 2.20\%$$

After analyzing the flexural strength data, it can be concluded that the KEVLAR / S-GLASS / CARBON FIBER composite exhibits superior flexural strength compared to the other composites.

S.NO	COMPOSITE	FLEXURAL TEST			
		LOAD(N)	ELONGATION(mm)	FLEXURAL STRESS(MPA)	ELONGATION(%)
1	CARBON	450	8.15	337.5	4.07
2	S GLASS	520	6.6	390	3.3
3	KEVLAR	335	7	251.2	3.5
4	KEVLAR/S GLASS	480	6.35	360	3.17
5	KEVLAR/CARBON	480	7.9	326.2	3.95
6	S GLASS/CARBON	460	5.8	345	2.9
7	KEVLAR/S GLASS/CARBON	495	4.4	371.2	2.2

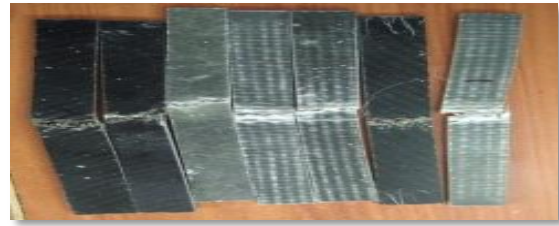
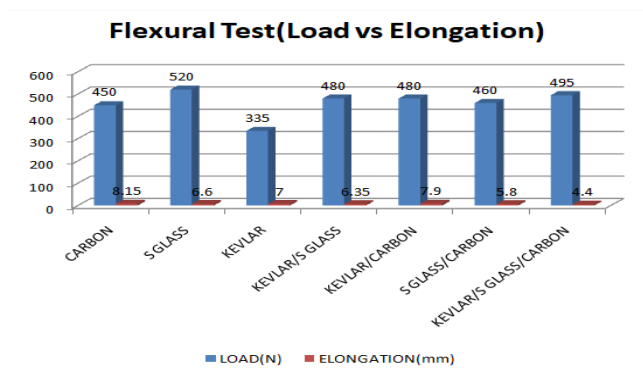

Figure - 27: Flexural strength specimens of all materials

Table - 2: Flexural testing results for 7 composites



Graph - 2: Flexural test result graph

5.4 Impact strength

The project encompassed the successful fabrication and comprehensive testing of impact strength for various composites, including Kevlar, Carbon fiber, S glass, Kevlar/Carbon fiber, Kevlar/Carbon fiber/S glass, Kevlar/S glass, and Carbon fiber/S glass. These composites were meticulously crafted using the hand lay-up technique to assess their impact resistance.

In conclusion, the hybrid composite material KEVLAR/CARBON/S GLASS demonstrated superior impact strength when compared to the other compositions.



Table - 3: Impact strength on all materials

S.NO	COMPOSITE	IMPACT TEST
		(J)
1	CARBON	2.7
2	S GLASS	3.7
3	KEVLAR	1.9
4	KEVLAR/S GLASS	3.2
5	KEVLAR/CARBON	2.6
6	S GLASS/CARBON	3.5
7	KEVLAR/S GLASS/CARBON	4.9

Figure - 28: Impact strength specimens of all materials

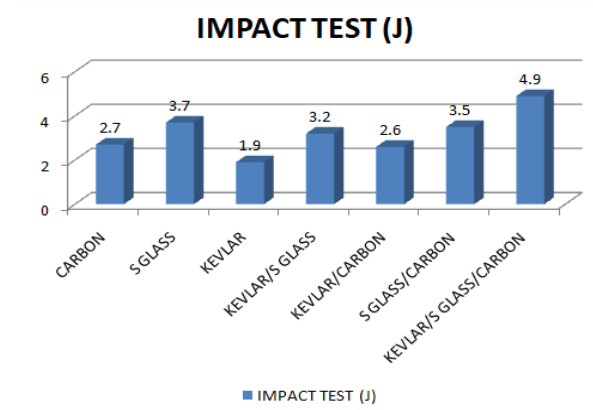

Graph - 3: Impact strength result graph

5.5 Hardness Number:

The Brinell hardness values of these natural composites were evaluated through experimentation. The KEVLAR/CARBON FIBER/S GLASS composition with 10% graphite powder exhibited the highest Brinell hardness value of 18.3, demonstrating a significant hardness improvement. This result was obtained considering the weight ratio of resin and hardener.

The graph depicting the relationship between Brinell hardness and experiment number for the composite is presented. The figure illustrates the Brinell hardness values associated with each experiment number. It is evident from the graph that the experiment involving Kevlar/Carbon fiber/S glass composite yields the highest Brinell hardness value.

S.NO	COMPOSITE	HARDNESS NUMBER
1	CARBON	100.65
2	S GLASS	62.41
3	KEVLAR	94.95
4	KEVLAR/S GLASS	59.51
5	KEVLAR/CARBON	130
6	S GLASS/CARBON	129.22
7	KEVLAR/S GLASS/CARBON	159.15

Table - 4: After testing of hardness test on all materials

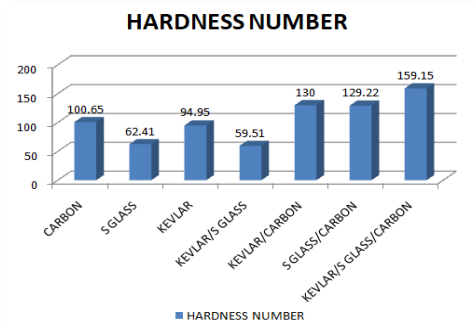

Graph - 4: Hardness number result graph



Figure - 29: Hardness testing specimens

6. INTRODUCTION TO CATIA

CATIA (Computer-Aided Three-Dimensional Interactive Application) is a widely used computer-aided design (CAD) software suite developed by Dassault Systems. It is renowned for its robust capabilities in creating, designing, simulating, and analyzing complex 3D models and products. Originally developed in the late 1970s, CATIA has evolved into one of the most powerful and comprehensive CAD tools available in the industry.

6.1 Key features of CATIA include:

6.1.1 Parametric modeling

CATIA offers a robust parametric modeling environment that enables users to create and modify 3D models using defined parameters and relationships. This approach allows for efficient design changes and updates.

Go to the sketcher workbench create the 1200x300 c shape using profile tool bar profile option and apply pad with thickness is using part design workbench again go to the front view XY plane create the front part gill area and light area apply pocket as per dimensions as shown below figure.



Figure - 30: Front view of car bumper

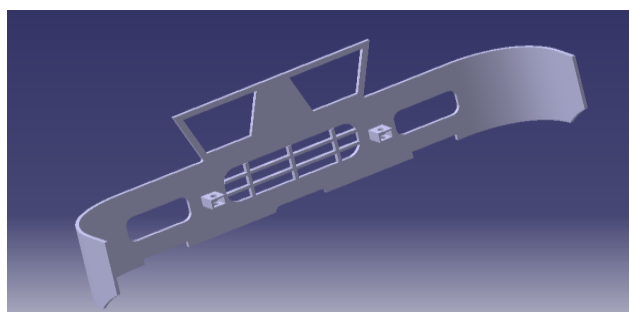

Figure - 31: Isometric view of the car bumper

6.2 Meshing

Meshing is the process of dividing a complex domain into smaller elements. These elements form a mesh, allowing for numerical analysis and simulations of physical phenomena.

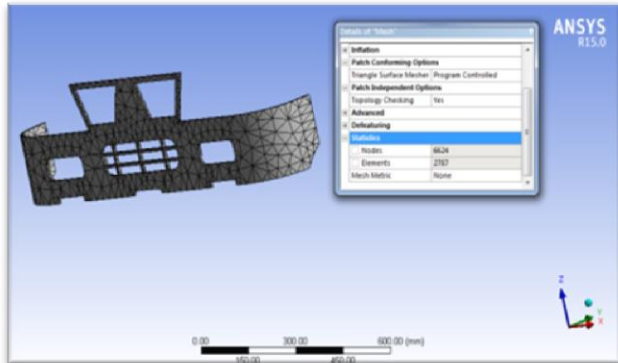

Figure - 32: Meshing:
 Nodes: 6624, Elements:2787

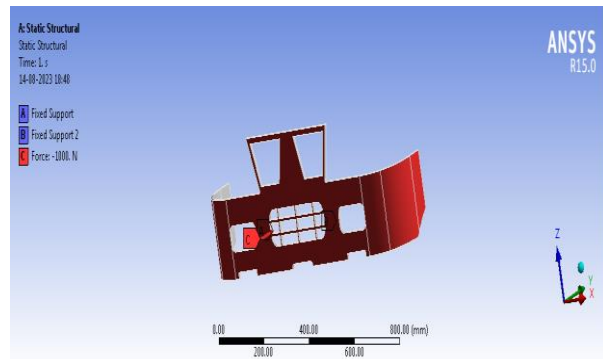

Figure - 33: Boundary conditions Force: 1000N on car bumper

6.3 Polypropylene Material

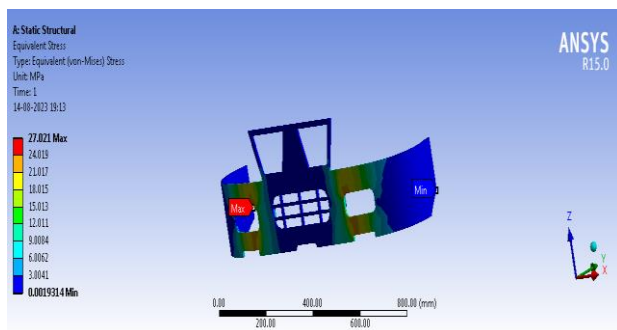

Figure - 34: Von-mises stress of Polypropylene material

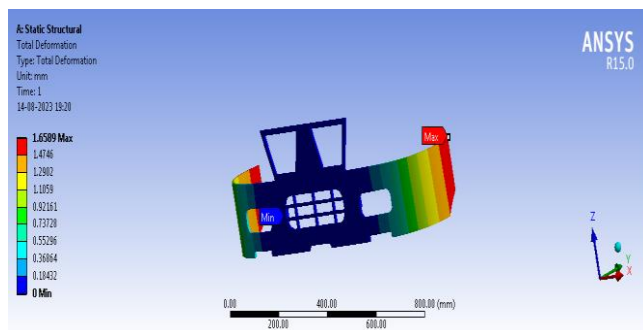

Figure - 35: Total deformation of Polypropylene material

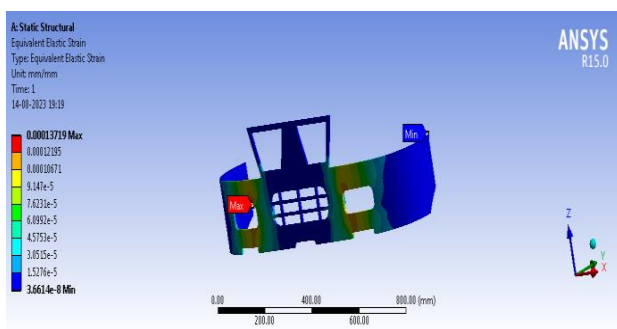

Figure -36: Strain of Polypropylene material

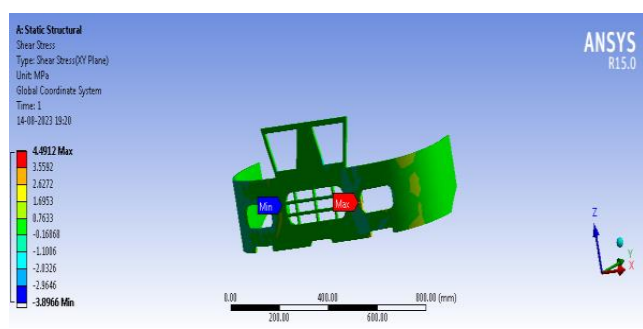

Figure -37: Shear stress of Polypropylene material

6.4 KSC Material

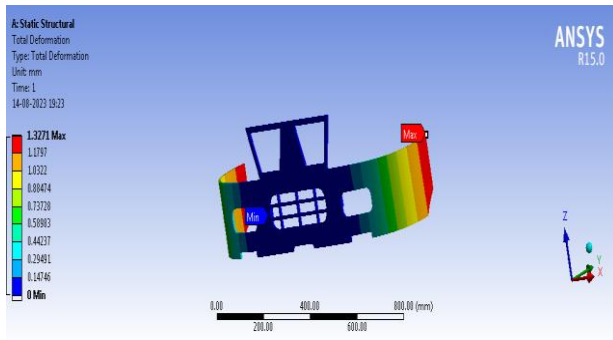

Figure - 38: Total deformation of KSC Material

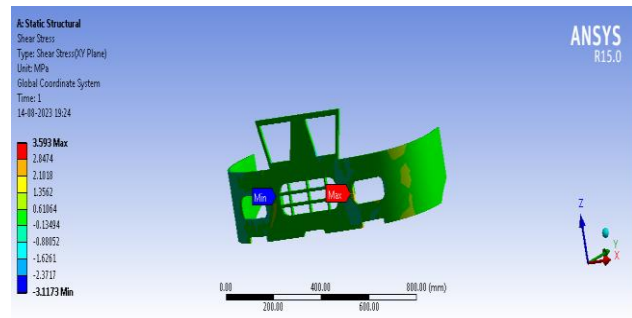

Figure - 39: Shear stress of KSC Material

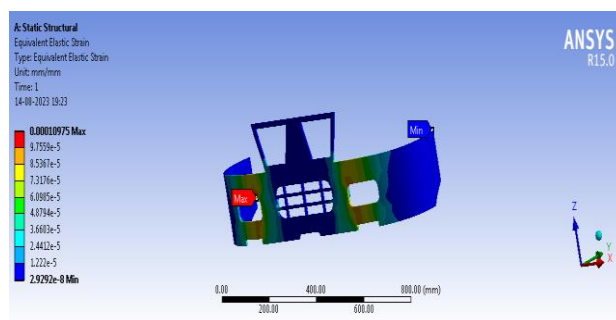

Figure - 40: Strain of KSC Material

Graphs

Our examination reveals that Polypropylene material exhibits the highest Von-Mises stress of 27.021 MPa, whereas KSC (Kevlar/S glass/Carbon fiber) material displays the lowest Von-Mises stress of 21.617 MPa, in comparison to the other materials. This data is visually depicted in the Von-Mises stress graph provided below.

6.5.1 Total deformation graph

Upon analysing the Total Deformation, it is evident that the car bumper's composition includes materials such as polypropylene, Kevlar, S glass, and Carbon fiber with 10% Graphite powder additives. Our examination reveals that Polypropylene material exhibits the highest Total Deformation of 1.65 mm, while KSC (Kevlar/S glass/Carbon fiber) material displays the lowest Total Deformation of 1.32 mm in comparison to the other materials. This information is visually depicted in the Total Deformation graph provided below.

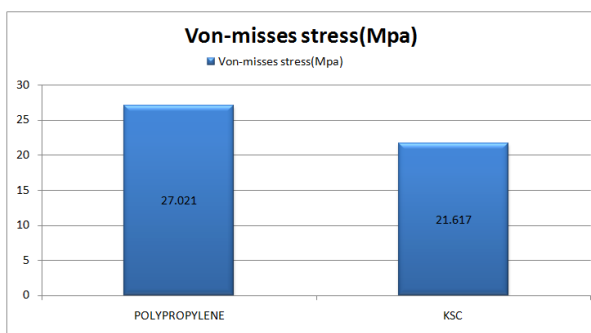

Graph - 5: Von-misses stress

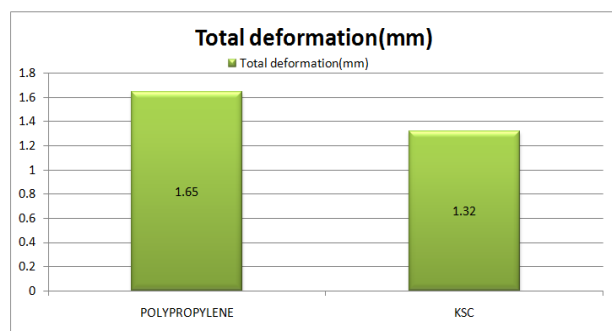

Graph - 6: Total deformation

6.5.2 Shear Stress & Strain graph

Upon analysing the Strain graph, it is evident that the car bumper is constructed using a combination of materials including polypropylene, Kevlar, S glass, and Carbon fiber with 10% Graphite powder additives. Our investigation reveals that the Polypropylene material exhibits the highest Strain value of 0.000137, while the KSC (Kevlar/S glass/Carbon fiber) material demonstrates the lowest Strain value of 0.000109 in comparison to the other materials. These observations are visually depicted in the Strain graph provided below.

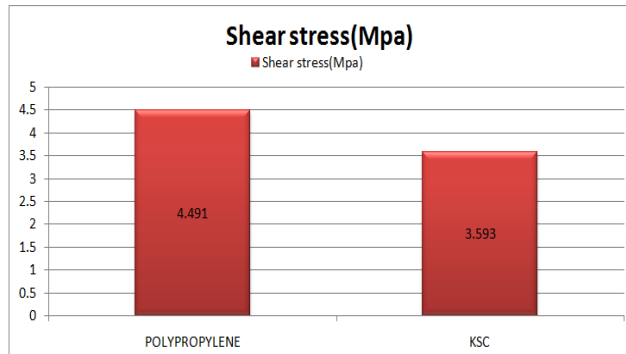

Graph - 7: Shear stress

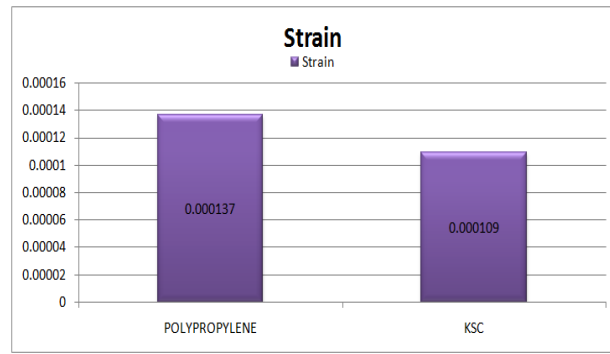

Graph - 8: Strain graph

7. CONCLUSION & FUTURE SCOPE

7.1 Conclusion

The primary objective of this study was to assess the feasibility of utilizing various combinations of materials, including Kevlar, Carbon fiber, S glass, Kevlar/Carbon fiber, Kevlar/Carbon fiber/S glass, Kevlar/S glass, and Carbon fiber/S glass, along with 10% graphite powder, in the fabrication process through the hand lay-up method. In this approach, epoxy served as the matrix material in the composite structure. Our investigation delved into assessing the mechanical properties encompassing tensile strength, flexural strength, impact resistance, and hardness characteristics of these composites.

7.2 Future scope

- 1. Powdered Fiber Incorporation:** An avenue worth exploring involves utilizing fiber in powdered form during the specimen fabrication process. This approach has the potential to enhance the overall strength of the composites.
- 2. Variety of Resins:** To comprehensively assess mechanical properties such as strength and wear resistance, experimentation with various types of resins could be undertaken. This would provide a more comprehensive understanding of the material behaviour.
- 3. Process Parameter Variation:** Investigating the impact of diverse process parameters on the composite properties holds promise. By altering parameters, such as temperature and curing time, it is possible to enhance the overall performance of the composites.
- 4. Diverse Composite Combinations:** Evaluating the mechanical properties of composites fabricated using different combinations of materials presents an opportunity for further research. By varying the types and proportions of fibers, as well as the matrix materials used, a broader range of material behaviours can be studied.

By delving into these areas, future researchers can contribute to a deeper understanding of composite materials and their potential applications in various fields.

8. REFERENCES

1. A comprehensive study conducted by Mohammed Hisham, Mohammed Fahaduddin, Mohammed Azhar Khan, Ashok B C, and Prashant Kumar Shrivastava delved into the realm of Kevlar and Hybrid Kevlar Composites. This research endeavor culminated in a report published in the International Journal of Recent Technology and Engineering (IJRTE),

under ISSN: 2277-3878. This illuminating report, featured in Volume 8, Issue 2S3, in July 2019, contributes valuable insights to the field.

2. In the realm of carbon fiber-reinforced sandwich structures, Tidong Zhao, Jing Yang, Jinxiang Chen, and Sujun Guan embarked on a comprehensive review. Their scholarly investigation, featured in *Polymers and Polymer Composites*, delves into the intricacies of these structures and was published in Volume 30, spanning pages 1 to 17. This article, enriched with insights, bears the DOI: 10.1177/09673911221098729, and its publication was facilitated by journals.sagepub.com/home/ppc.
3. The realm of hybrid composite material's mechanical properties was explored through an experimental study conducted by Manjunath Pattan, Bipin J, Sudarshan Shetty, and Sajjan S.C. This insightful research was featured in the *International Journal of Engineering Research & Technology (IJERT)*, under ISSN: 2278-0181. The culmination of this study is encapsulated within the NCMPC - 2019 Conference Proceedings.
4. Mohamad Barkat Ibrahim, Hussein Yousef Habib, and Rafi Mousa Jabrah undertook the task of preparing Kevlar-49 Fabric/E-Glass Fabric/Epoxy Composite Materials. Their meticulous work in characterizing the mechanical properties of these hybrid composite materials led to intriguing findings. The resultant Kevlar/glass/epoxy hybrid composite materials exhibit mechanical properties that often bridge the gap between Kevlar/epoxy and glass/epoxy composite materials. This work was facilitated by mohammad.ibrahim@hiast.edu.sy and is accessible through the DOI: <https://doi.org/10.18280/rcma.303-403>.
5. An in-depth exploration of "Fiber Fracture In Hybrid Composite Systems" was undertaken by Keith D. Jones and Anthony T. DiBenedetto. This comprehensive investigation is chronicled in the pages of *Composites Science and Technology*, volume 51 (1994), spanning pages 53-62.
6. A significant study led by Ting-Ting Li, Rui Wang, Ching-Wen Lou, and Jia-Horng Lin delved into the "Static and dynamic puncture behaviours of compound fabrics with recycled high-performance Kevlar fibers." This research can be found in *Composites: Part B*, volume 59 (2014), covering pages 60-66.
7. Jin Zhang, Khunlavit Chaisombat, Shuai He, and Chun H. Wang ventured into the realm of "Hybrid composite laminates reinforced with glass/carbon woven fabrics for lightweight load bearing structures." Their valuable insights are preserved in *Materials and Design*, volume 36 (2012), spanning pages 75-80.