

SMART RESTRAINT SYSTEM

SANGAMITHRA.S¹, AMETHESH.L.G.P², HARIRAGHAV.S³, GOPINATH.G.K⁴, HARIHARA VELAN⁵

¹Assistant Professor Department of Computer Science and Engineering,
K.L.N. College of Engineering and Technology, Sivagangai, India
^{2,3,4,5}Student, Department of Computer Science and Engineering,
K.L.N. College of Engineering and Technology, Sivagangai, India

Abstract-The SMART RESTRAINT SYSTEM enhances vehicle safety by employing occupant detection sensors, including a Heartbeat Sensor, to verify seat belt usage. It addresses the issue of people trying to bypass seat belt safety measures, a leading cause of road accident fatalities. When an occupant is absent, the system activates an alarm to remind and monitor seat belt status, ensuring safety compliance even in empty vehicles. Beyond occupant detection, the system integrates an ignition interlock via the Internet of Things (IoT) and a relay, serving as a critical safety feature. If an unauthorized person attempts to start the vehicle, the IoT system notifies the authorized user via IFTTT, who can then interlock the ignition via IoT, preventing unauthorized access. Importantly, remote engine start is not possible, maintaining control and security. This system acts as a bridge between the vehicle's engine and authorized users, upholding safety and security while allowing authorized operation.

Key Words-Ignition Interlocking through relay, IOT, Seatbelt Monitoring, Heart Beat Sensor, IFTTT, Blynk, etc.

1.INTRODUCTION

In the dynamic realm of vehicle safety and IoT technology, innovative solutions have emerged to enhance road safety, with a focus on seatbelt monitoring and ignition interlocking. These systems feature a 3D printed magnetic buckle switch as their starting point, promoting safety in commercial vehicles and fleet management. The system employs a heart rate sensor using photoplethysmography to monitor passengers' heart rates. Data is transmitted to a NodeMCU, which sets a bias limit for heart rate evaluation. If the data falls outside this limit, an alarm is triggered, alerting the driver or a central monitoring system. This approach not only ensures seatbelt usage but can also identify medical emergencies or unsafe conditions. The system distinguishes between correctly and improperly fastened seatbelts, triggering alarms for the latter. This proactive reminder enhances safety, provided the system is accurately calibrated to minimize false alarms. The ignition interlocking system includes a relay and an alert mechanism. Unauthorized ignition attempts trigger email alerts through IFTTT, promptly notifying vehicle owners or authorized personnel. It also integrates with Blynk, allowing remote ignition control, enhancing security and convenience. This system not only deters unauthorized use but also empowers vehicle owners to take immediate action, safeguarding the vehicle and the environment.

The main objective of our innovative system is to advance vehicle safety and security through IoT technology, with a primary focus on two essential components: seatbelt monitoring and ignition interlocking.

2.RESEARCH AND FINDINGS

In order to gain a deeper understanding of the problem domain, extensive research was conducted, encompassing a thorough analysis of various accident cases, research papers, previously developed systems, and those currently in use. This comprehensive approach allowed us to investigate the root causes of injuries occurring during accidents and the failures of existing safety features. Additionally, we delved into the factors contributing to the underutilization of seat belts, which include weak legal enforcement, negative image perceptions, a lack of awareness regarding seat belts as safety devices, and the influence of family and friends who do not wear or encourage their usage. Through our research, it became apparent that the existing system primarily focuses on maximizing the effectiveness of seat belts to ensure passenger safety.

In contrast to the existing system, our proposed solution incorporates an array of sensors designed to collect data on various parameters, with a primary emphasis on detecting the presence of an occupant and monitoring seat belt status. These sensors

include IR Sensors and Load Cells for confirming human presence in the vehicle, as well as Reed Switches, RFID technology, and additional IR Sensors to track the status of the seat belt. All the sensor data is seamlessly transmitted to a microcontroller, which, in turn, allows engine ignition only when the occupant has properly fastened their seat belt. Notably, the current system leverages a range of deep learning algorithms to accurately determine seat belt status. In summary, our innovative approach enhances safety by utilizing multiple sensors to detect occupants and monitor seat belt status, ultimately enabling engine ignition only when seat belts are correctly fastened. This stands in contrast to the existing system, which primarily focuses on maximizing seat belt effectiveness for passenger safety.

When considering the cost implications, it becomes evident that the existing system is at a disadvantage due to its higher level of complexity resulting from the implementation of deep learning algorithms. While these algorithms offer sophisticated seat belt status determination, they come at a greater financial cost. Additionally, the existing system has limitations when it comes to emergency situations. It is unable to operate effectively during critical moments, potentially jeopardizing passenger safety. Furthermore, the system's adaptability to different environments is limited, which can be a hindrance in various real-world scenarios. Our proposed system, on the other hand, presents a cost-effective alternative with improved adaptability and responsiveness to emergencies, making it a compelling choice for enhancing occupant safety in vehicles.

3. ENHANCED VEHICLE SAFETY AND SECURITY FEATURES

Our proposed solution employs an array of advanced sensors, including a Heartbeat sensor, to gather data on various parameters related to occupant detection. This innovative approach ensures that the system is capable of detecting the presence of an occupant accurately. In cases where no occupant is detected, the system activates an alarm, effectively monitoring the seat belt status to enhance safety.

Moreover, our solution incorporates an ignition interlocking system through a relay. This means that the engine can only be started when the occupant has properly fastened their seat belt. This feature adds an additional layer of safety and ensures that seat belts are being used effectively.

In situations where an unauthorized individual attempts to start the vehicle, a notification is promptly sent to the authorized user through the IFTTT (If This Then That) platform. This enables the authorized user to take immediate action, such as remotely turning off the engine through the Blynk platform. This functionality provides an extra layer of security and control, preventing unauthorized use of the vehicle.

It is important to highlight that while the ignition can be interlocked through the Internet of Things (IoT), the engine cannot be started remotely. This design choice prioritizes security and prevents any potential misuse of the system. In summary, our proposed system not only enhances occupant safety by utilizing advanced sensors for occupant detection and seat belt monitoring but also provides additional security features to prevent unauthorized vehicle use, all while maintaining a strict control over engine ignition.

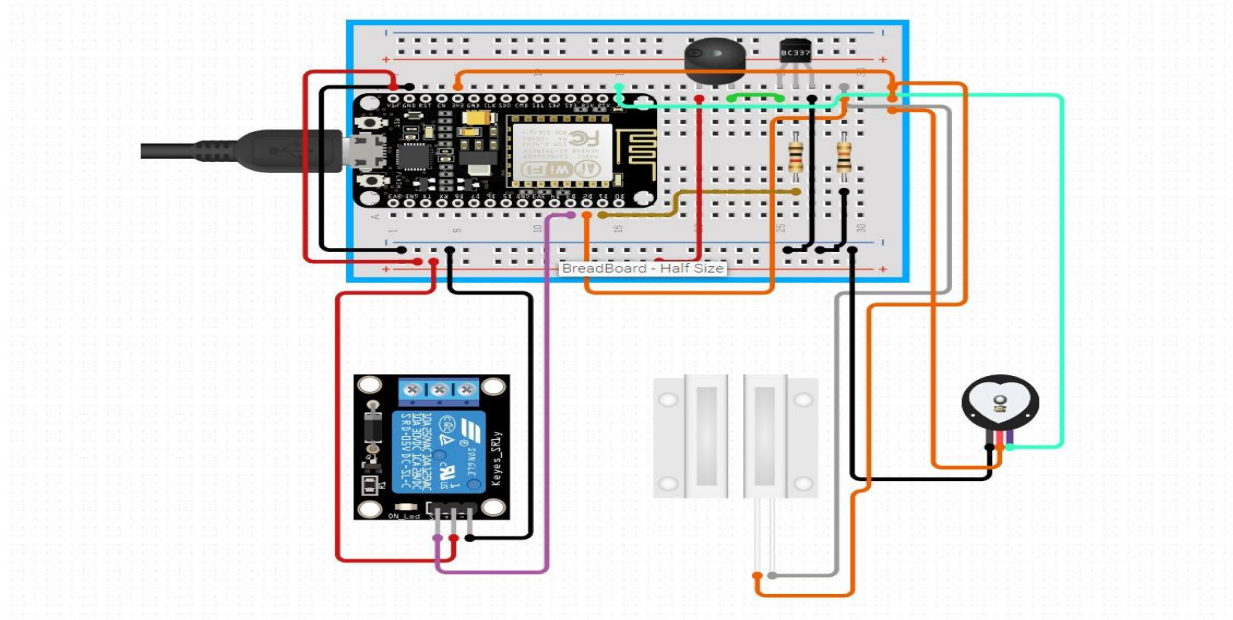

Figure-1: Circuit Diagram

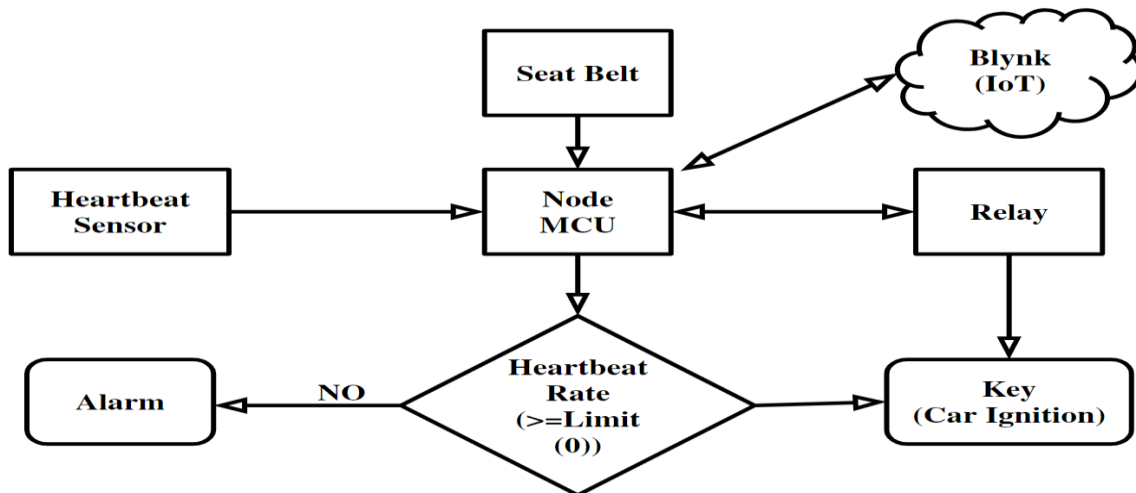

Figure 2: Flow Chart

These diagrams help us understand the flow of our proposed system in a simple way. First, the seat belt is buckled up, through which the system will start. The heartbeat sensor begins to detect the heartbeat, and if it falls within the predefined limits, the buzzer will go off. Otherwise, the buzzer will turn on, and the relay is activated. When the relay is turned on, a notification will be sent to an authorized user via IFTTT and can be controlled through Blynk the all actions in this system are processed through Node MCU. Following are the major components used in our system,

1) Node MCU

NodeMCU is an open-source firmware and development kit designed for the ESP8266 Wi-Fi module. It simplifies the process of programming and working with the ESP8266, making it a popular choice for building Wi-Fi-enabled IoT devices and projects.

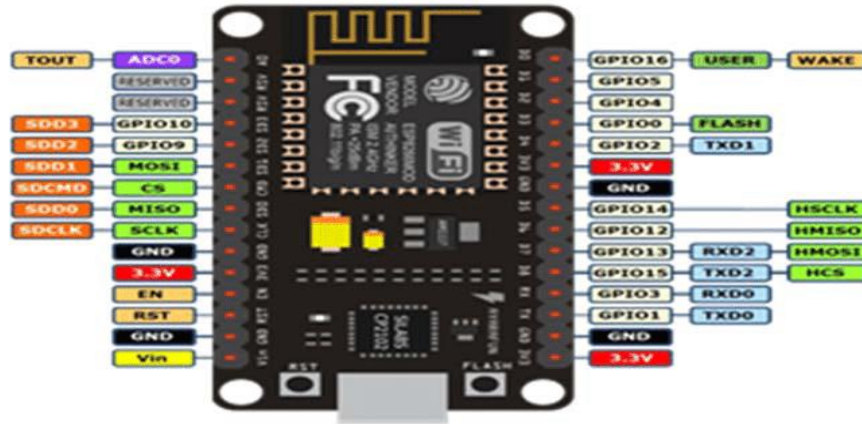

Figure 3: Node MCU

2) Heartbeat Sensor

A heartbeat sensor, also known as a heart rate sensor, is a device that measures a person's heart rate or pulse by using light to detect changes in blood flow under the skin. It's often used in fitness trackers, medical devices, and other applications to monitor heart rate.

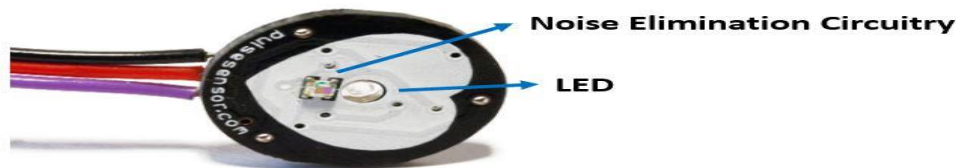

Figure 4: Heartbeat Sensor

3) Relay

A relay is an electrical switch that operates through an electromagnet. It's a device used to control the flow of electric current in an electrical circuit. Relays are particularly handy when you need to allow a low-power signal to control a high-power load or to isolate different parts of an electrical circuit.



Figure 5: Relay

4.CONCLUSION

- **Innovative Ignition:** The system uses a unique 3D printed magnetic buckle as an ignition key, providing a secure and novel way to start the vehicle.
- **Occupant Detection:** Continuous monitoring through sensors, including a heartbeat sensor, ensures that the system detects the presence of occupants. If no occupants are detected, it triggers an alarm to prevent potential dangers.
- **Seat Belt Monitoring:** The system also keeps a vigilant eye on seat belt usage. It can issue warnings or alarms if an occupant is detected but not wearing a seat belt, promoting a culture of safety within the vehicle.
- **Ignition Interlocking:** An ignition interlocking system, using a relay, adds an extra layer of safety by allowing the vehicle to ignite remotely, enhancing overall safety.
- **Security Against Unauthorized Ignition:** The system recognizes unauthorized ignition attempts and immediately notifies the authorized user, usually through platforms like IFTTT, empowering them to take prompt action.
- **Remote Engine Control:** Using platforms like Blynk, the authorized user can remotely disable the engine, even if the vehicle is started without authorization. This serves as a fail-safe mechanism against theft or unauthorized use.

REFERENCES

- [1] Yanxiang Chen , Gang Tao , Hongmei Ren , Xinyu Lin, Luming Zhang,," Accurate seat belt detection in road surveillance images based on CNN and SVM, " in science direct on November 2018.
- [2] Manu Vyas,Mani Kunnathettu,Rajee,Shrikant Subhash Warghade,,"Active seat belt system" in International Conference on Nextgen Electronic Technologies: Silicon to software on March 2017.
- [3] Alexey Kashevnik, Ammar Ali, Igor Lashkov, Nikolay Shilov SPIIRAS,," Seat Belt Fastness Detection Based on Image Analysis from Vehicle In-cabin Camera" in International Conference on Consumer Electronics and Computer Engineering on April 2020.
- [4] Dongsheng Yang, Ying Zang Qingshan LiuOn, " Study of Detection Method on Real-time and High Precision Driver Seatbelt" in International Conference on Consumer Electronics and Computer Engineering on August 2020.
- [5] Dr. Harshal Shah¹, Kishankumar Patel², Nitya Patel³, Nishil Patel⁴, Rutvik Patel "Ignition Interlocking Seat Belt" in International Research Journal of Engineering and Technology (IRJET) on Apr 2020.
- [6] Qiao Yi ,Qu Yi "Safety Belt Wearing Detection Algorithm Based on Human Joint Points" in International Conference on Consumer Electronics and Computer Engineering on January 2021.