

Design and Testing of Fin Ray Soft Gripper's Finger

Vishal S P¹, Vimal Raj S², Sri Varshan G³, Vivekan P⁴

^{1,2,3,4} UG Scholar, Department of Mechanical Engineering, Coimbatore Institute of Technology, Coimbatore.

Abstract - Fin ray soft grippers are a kind of soft robotics end-effector that mimics the flexible fins of fish. In comparison to conventional rigid grippers, these grippers have a number of benefits, such as improved flexibility and adaptability to various objects of different shapes and sizes. Fin Ray soft gripper offer significant advantage when operating in dynamically changing or unstructured environment, especially when interacting with soft and delegate objects. The objective of this research is to optimize the performance of fin ray soft gripper's fingers by establishing correlations between design parameters and finger performance. This will be achieved through a combination of simulation-based analysis and eventual experimental validation. The chosen design parameters for optimization were rib structure, rib thickness and orientation of the ribs. By changing these parameters nine fingers were designed, analyzed and optimized. Deformation and tip deflection of the fingers has been tested in real life environment. The results showed that the grippers are efficient in both wrap around grasping and pinch grasping.

Key Words: Fin Ray Gripper, End-Effector, Simulation – based analysis, Rib structure, Rib thickness, Rib orientation, Deformation, Tip deflection, Wrap around grasping, Pinch grasping

1.INTRODUCTION

This Grasping and manipulation are essential functions shared by both animals and robots. In simplified terms, grasping refers to the ability to pick up and securely hold an object despite external disturbances, while manipulation involves exerting forces on an object to rotate and displace it relative to the manipulator's reference frame. Within the context of this article, the term "gripper" is employed to describe robotic end effectors that possess the ability to offer one or more of the mentioned functionalities, namely grasping and manipulation [1]. Robotics grippers are highly significant components in various industries due to their exceptional ability to manipulate objects. They find application in diverse fields, including agriculture, packing, space exploration, and many more. Their versatility makes them indispensable for performing a wide range of tasks in different domains. Traditional hard robotic grippers typically comprise rigid joints and links, which require precise adaptation to avoid damaging the object being manipulated. As a result, their usage is restricted to specific types of objects. When a diverse range of objects needs to be manipulated, it becomes highly challenging, if not impossible, for a rigid gripper to grasp them effectively [2].

On the Other hand, Soft robotic grippers are designed with flexible materials and structures, allowing them to deform and adapt to various objects. Unlike traditional hard grippers, soft robotic grippers can safely grasp and manipulate objects of different shapes, sizes, and textures without causing damage. The compliance and flexibility of soft grippers enable them to conform to irregular surfaces and handle fragile items with gentleness and precision. These grippers have found applications in fields like healthcare, manufacturing, and robotics research, where their ability to handle delicate or complex objects is highly valued.

Fin ray soft grippers are a type of soft robotics end-effector that utilize a biomimetic design inspired by the flexible fins found in marine animals such as fish and rays. The unique properties of the fin rays make them an ideal template for the development of soft robotics technology, particularly for soft grippers that require a high degree of dexterity and adaptability to different objects of varying shapes and sizes. The Fin Ray Effect [3] is a key mechanism that underlies the function of fin ray soft grippers. The effect is based on the observation that the structure and motion of the fins of marine animals can be replicated using a flexible material such as silicone. When a flexible fin is bent or deformed, the outer surface of the fin stretches and thins while the inner surface compresses and thickens. This results in a change in the overall shape of the fin, which can be harnessed to generate useful forces or movements. In soft grippers, the Fin Ray Effect is used to create a structure that can conform to the shape of an object and exert precise control over gripping forces. The gripper consists of a flexible base material, typically silicone or a similar elastomer, that is embedded with a series of thin, flexible fin rays [4]. When the fin rays are actuated, they bend towards the object to be gripped, conforming to its shape and exerting a gripping force. The degree of bending and force exerted can be precisely controlled by adjusting the actuation pressure and the geometry of the fin rays. One of the key advantages of fin ray soft grippers is their ability to adapt to objects of varying shapes and sizes. The fin rays can bend and deform to match the contours of the object, providing a secure grip that minimizes the risk of slippage or damage. They are lightweight, compact, and can be easily integrated with other soft robotic components, such as sensors and actuators. They are also less likely to damage delicate or fragile objects, making them ideal for use in applications such as surgery, harvesting of fruits and vegetable, space exploration operations.

In this paper, a soft gripper is introduced that enhances the gripping capability by using Fin Ray effect. This gripper is specifically designed for handling delicate objects like fruits, vegetables and cakes. By improving upon the original design, the soft gripper offers superior performance in grasping objects. Its innovative features aim to optimize efficiency and accuracy in industrial applications. Existing soft robotic grippers are commonly available in two-fingered and three-fingered configurations. In comparison to the two-fingered configuration, the three-fingered configuration provides several advantages. It ensures a more balanced position for the grasped object and offers a larger contact surface area, enhancing the grip [3]. Therefore, for our gripper design, we opted to utilize three fingers that are evenly distributed. These robotic fingers draw inspiration from fish fins utilizing the Fin Ray effect to automatically wrap around the object being grasped, regardless of its shape. This design choice enhances the gripper's versatility and enables it to accommodate objects of various shapes and sizes. Chapter 1 gives detailed introduction about the paper, then followed by literature review in Chapter 2. Chapter 3 explains the design and parameters involved in the design of fin ray soft gripper. It also summarizes the result of ANSYS analysis of the gripper. Deformation Testing and Deflection Testing of the fingers has been discussed in Chapter 4 and Chapter 5 respectively. Chapter 6 concludes the paper. The Scope of the project is to test several soft grippers designs to determine which grippers deflect most without damaging the object being picked. The project mainly focuses on improving the fin ray soft gripper finger design for effective deformation and deflection and to create a gripper that can safely handle fragile objects.

2. LITERATURE REVIEW

Shin et al (2021) discussed about metamaterial-integrated soft grippers. It has always been ideal to have a single universal robotic gripper that can carry out a variety of gripping and grasping operations [4]. Elgeneidy et al (2019) mainly focuses on the soft gripper's actuation by cable-driven mechanisms. How various channel locations and geometries function under various loads and loading situations were discussed [6]. Jun Shintake et al (2018) covered every fundamental aspect of the soft gripper. This article clearly explains about various actuation and gripper types. Each sort of gripper is briefly explained, and a graphic illustrating how they grasp an object is provided [1]. Yang Yang et al (2021) draws inspiration from the fin ray effect. Force feedback is offered and the gripper is 3D printed. The actuation is carried out mechanically using a wire and stepper motor. Different objects are analyzed, and the findings are shared [3]. Chih-Hsing Liu et al (2020) highlighted the ideal soft-gripper design that is powered by a motor. The substance that makes up a thermoplastic elastomer. The mathematical equations are used to discuss the entire design [5]. Md. Hazrat Ali et al (2019) observed the ideal soft-gripper design that is powered by a motor. The substance that makes up a thermoplastic elastomer. The mathematical equations are used to discuss

the entire design [7]. Charbel Tawk et al (2019) proposed recent advances in material science and engineering disciplines have significantly impacted the field of robotics, leading to the development of numerous bioinspired soft robots. Soft Adaptive grippers are the most studied classes of soft grippers. Using a cost-effective and open-source fused deposition modeling (FDM) 3D printer, along with a commercially available thermoplastic polyurethane (TPU), the soft gripper was successfully printed in a single step. [8]. Whitney Crooks et al (2016) explained about a gripper that is inspired by the Fin Ray Effect, which is derived from the physiology of fish fins. The gripper fingers are designed to be soft and triangular in shape, with hard crossbeams that can buckle and deform to conform around objects. This unique design enables the fingers to change direction, reducing the amount of force needed to achieve a secure grip on an object. Moreover, the entire gripper, which consists of both hard and soft materials, can be 3D printed as part of a soft robotic hand. Additionally, the motor tendon actuation system can be attached with ease, requiring only a limited number of steps. [9].

Xiaowei et al (2020) proposed a kinematic model to study the deflection and deformation of fin ray soft gripper. This paper offers a detailed exploration of the mathematical modeling and performance analysis of parallel grippers equipped with soft fingers, capitalizing on the advantages provided by the Fin Ray effect. Through rigorous mathematical modeling, the paper formulates equations and algorithms to accurately describe the behavior and performance of the gripper system. It investigates how various parameters, including the bending stiffness of the fingers, actuation forces, and contact forces between the fingers and objects, affect the gripping capabilities [10]. Zhifeng Deng et al (2021) determined the optimal geometry design for a Fin Ray finger when presented with a specific object to be grasped. We approach this problem by incorporating a grasp quality function that combines the characteristics of the object's shape and the geometry of the deformed finger. The objective is to identify the geometry that yields the highest grasp quality, indicating the most effective and reliable grasping capability for the given object [11]. Silvia Terrile (2021) proposed a comparative study is to assess and compare the performance of various grippers when subjected to identical conditions. The study involves evaluating multiple grippers under standardized testing conditions to ensure a fair and unbiased comparison. And measure and analyze factors such as gripping force, stability, and reliability to quantify the performance of each gripper [12].

3. METHODS AND MATERIAL

The suggested gripper can be conceptually divided into three distinct parts: the driving part, the working part, and the coupling part. The driving part is responsible for initiating and controlling the gripper's movements.

It encompasses various components, like step down transformer, Full wave rectifier, DPDT switch and a DC

motor. The working part of the gripper is specifically designed for effective object manipulation. This design facilitates adaptability to the shape of the object being gripped, ensuring a secure hold. The flexibility and compliance of the finger enable it to conform to the object's contours and increase the gripper's gripping capabilities. The coupling part of the gripper serves as the mechanism to connect the motor with the gripper's functional components. In this suggested design, the coupling part is realized through the implementation of a gripper centre screw. This screw enables the transmission of the motor's rotational force to the gripper, facilitating the desired gripping action. To provide structural support, the gripper is mounted on a support frame constructed using PVC (Polyvinyl chloride) and Polycarbonate sheets.

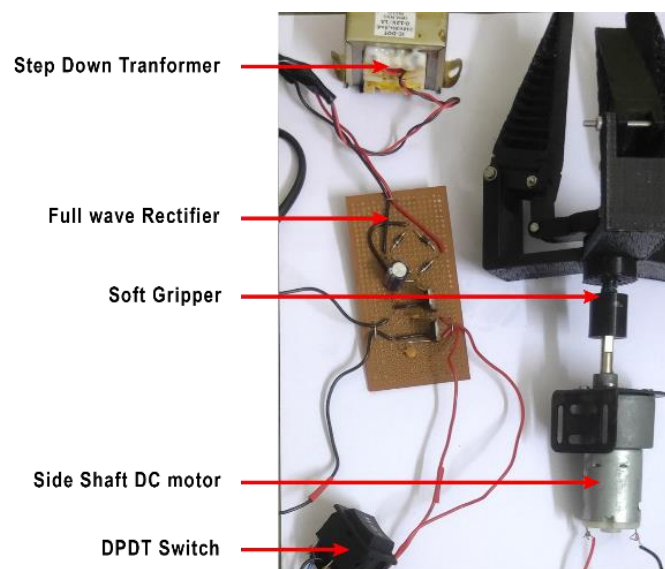

Fig -1: Gripper Set up

3.1 Design of Soft Gripper

The robotic gripper's fish fin construction makes it more adaptable and somewhat stable when grasping objects, enabling it to easily handle a variety of objects. The benefits and traits of the Fin Ray structure have been well researched. As a result, we have incorporated both the inner patterns and the Fin Ray structure. The fins are joined by an elastic framework and the ribs are spaced diagonally from the fingers. The finger can fit closer because to the hollow construction between the fins, which is flexible and can be changed by outside influences [1]. The number of ribs, slope of the outer wall, and slope of the ribs (Figure 2) were three geometric finger characteristics taken into consideration. A rib is an interior wall that runs parallel to the underside of the fin in the original Fin Ray specification. The angle between the base and external wall (ray) is known as the slope of the outer wall. Solid works is used for designing the gripper [4].

Even though the Fin ray gripper is softer than other others grippers, certain rib structures make them rigid. Force response of the fin ray gripper can be enhanced by design modification. Further improvement in force response can be achieved by tilting the rib from its default rib orientation. If the ribs are thinner and more flexible it will increase the distribution of contact force across length of the finger which is efficient for handling delicate objects. The flexible ribs jam together as they deform, increasing the finger's overall stiffness due to friction between the layers, which in turn results in a higher rate of force generation in the fingers with tilted ribs. This behavior is what causes the fingers with tilted ribs to exhibit an enhanced rate of force generation. The gripper can be operated in jammed and relaxed mode depending on how the finger placed with respect to the target. A finger with thin and flexible ribs possesses a notable softness, allowing for even distribution of forces and easy deformation in response to contact. Such a finger can adapt gently to the shape of the target. However, reducing the thickness of both the rib and the outer shell is expected to decrease the generation of force. While this would be advantageous for grasping delicate objects, it would also limit the maximum weight the fingers can handle and restrict their use in tasks that require exerting force against rigid targets [6]. It is important to note that as the rib thickness decreases, the flexibility of the gripper increases, but at the same time, the load-carrying capacity decreases. Thus, there is a trade-off between flexibility and load-carrying capacity. Among the three geometric parameters considered in finger design, the number of ribs has a significant impact on displacement of the finger. Increasing the number of ribs resulted in higher stress applied to the object and reduced displacement at the fingertip. The distribution of ribs plays a vital role in determining the performance of the gripper, as they are key components that influence the stiffness of the finger. Therefore, the arrangement and number of ribs should be carefully considered to optimize the gripper's performance. The Slope of outer wall has significant impact on the stress. Wall thickness also plays a major role in deflection of the gripper [6]. It is important to note that each structural parameter had distinct effects on both stress and displacement, showcasing significant differences in their influences. [4]. On keeping all this in mind the Gripper was designed for effective deformation, force generation and jamming capabilities.

By iterating the Structure of ribs, Number of Ribs, Slope of ribs we have designed nine gripping (Type 1 Iteration 1, Type 1 Iteration 2, Type 1 Iteration 3, Type 2 Iteration 1, Type 2 Iteration 2, Type 2 Iteration 3, Type 3 Iteration 1, Type 3 Iteration 2, Type 3 Iteration 3,) fingers with the rectangle and trapezoidal structured ribs of 3 different slopes, upward parabola, downward parabola and triangular.

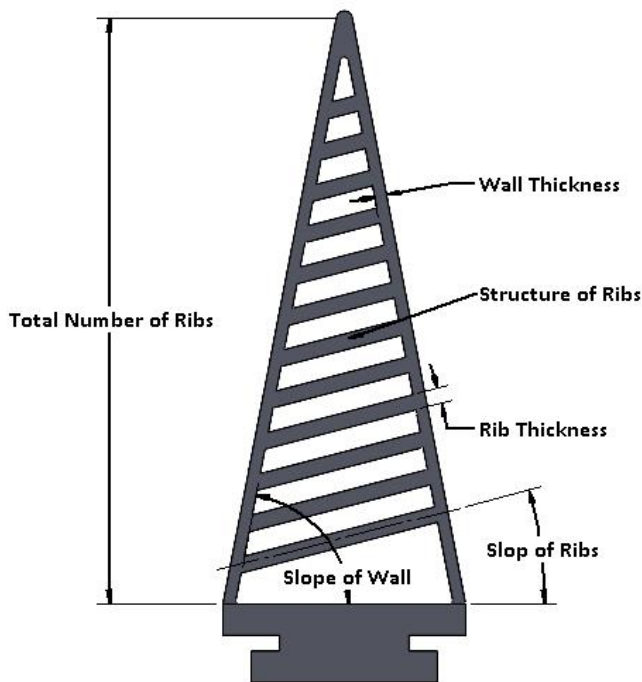

Fig -2: Fin Parameters

The gripper comprised of various essential components that work together to achieve effective object manipulation. These components include the gripper base, gripper slider, gripper center screw, gripper finger, gripper finger base, connecting links, and connecting rod. Each of these parts is meticulously designed and modeled using SolidWorks, a widely used computer-aided design (CAD) software, ensuring precision and accuracy in their construction. The central element of the gripper mechanism is the gripper center screw, which is securely connected to motor. As the motor rotates, the center screw rotates along with it, serving as the driving force for the gripper's actuation.



Fig -3: Type 1 Iteration 1

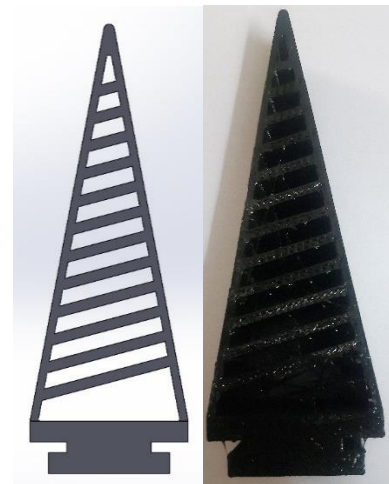

Fig -4: Type 1 Iteration 2

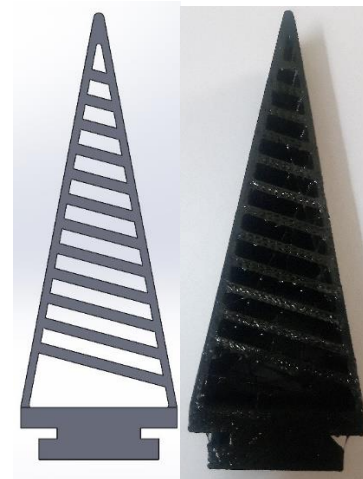

Fig -5: Type 1 Iteration 3

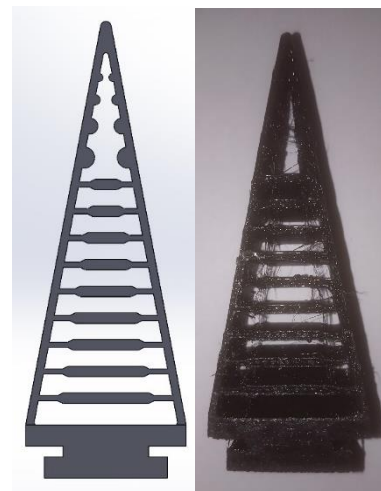

Fig -6: Type 2 Iteration 1



Fig -7: Type 2 Iteration 2

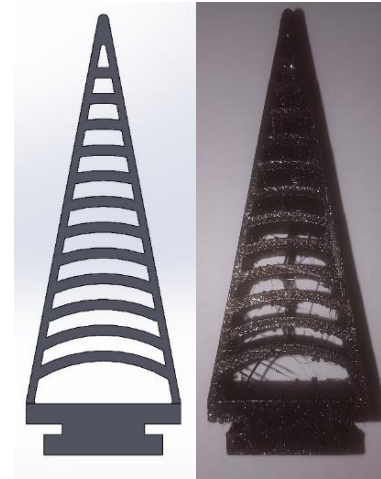

Fig -10: Type 3 Iteration 2

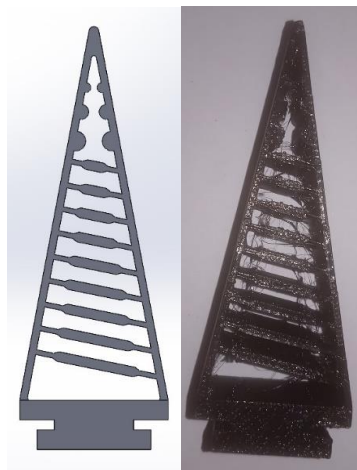

Fig -8: Type 2 Iteration 3

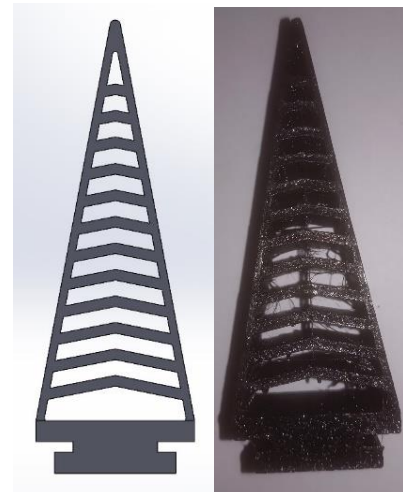

Fig -11: Type 3 Iteration 3



Fig -9: Type 3 Iteration 1

The gripper slider, in turn, smoothly slides along the length of the screw when it is set into motion. This coordinated movement facilitates the gripping action of the gripper. The gripper's functionality is based on the slider crank mechanism [7], which enables precise and efficient actuation of the gripper for optimal gripping performance.

This mechanism consists of the gripper slider, connecting rod, and other relevant components that work together to convert the rotational motion of the center screw into a linear sliding motion of the gripper slider. The slider crank mechanism ensures smooth and controlled movement, allowing the gripper to exert the necessary force and achieve an accurate grip on objects. One significant advantage of this gripper design is its ability to handle soft and delicate objects without causing any damage. The careful selection and arrangement of the components, as well as the implementation of the slider crank mechanism, contribute to the gripper's gentle and precise gripping capabilities. This feature makes the gripper suitable for a wide range of applications, including tasks that involve fragile materials or objects requiring careful handling.

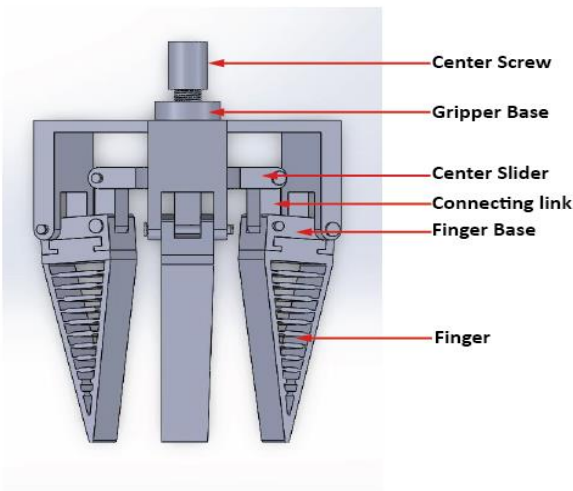

Fig -12: Parts of Gripper

3.2 FEM of Soft Gripper's Finger

The gripper finger design is based on the Fin Ray effect, leverages a geometric deformation principle to ensure conformity with the object being gripped. This design requires a significant degree of bending ability to effectively adapt to various object shapes. To evaluate the performance of the gripper finger design, a Static Structural analysis was conducted using ANSYS Workbench. The analysis focused on a single gripper finger made of TPU (Thermoplastic Polyurethane) material and subjected it to a 5N force. The force was applied to the gripping surface, while the base of the finger was fixed to simulate a realistic gripping scenario. The Analysis was performed on all Nine finger types. The objective is the determine the effective finger design. After evaluating the results of the analysis, it was determined that Type 2 Iteration 1, Type 2 Iteration 2, and Type 2 Iteration 3 proved to be the most effective designs. These iterations exhibited the desired level of performance and demonstrated the ability to effectively grip objects under the given force conditions.

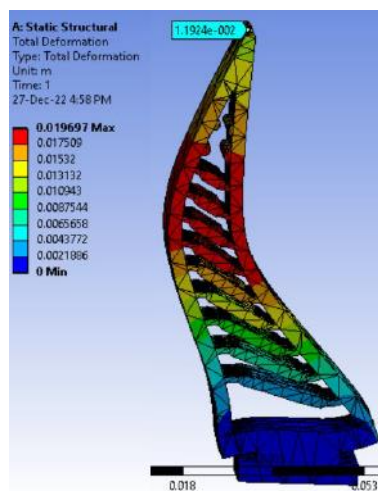

Fig -13: Analysis of Finger Type2 Iteration 1

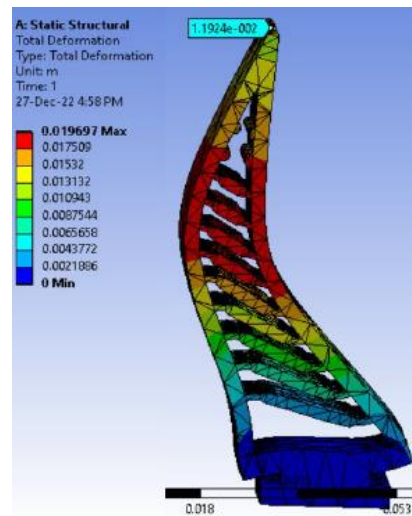

Fig -14: Analysis of Finger Type2 Iteration 2

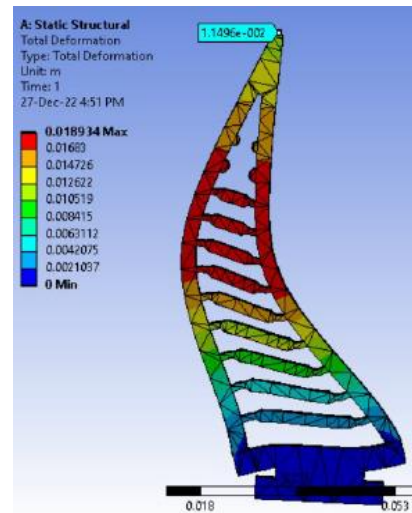

Fig -15: Analysis of Finger Type2 Iteration 3

Type 2 Iteration 1 of the gripper finger design featured a trapezoidal cross-section with ribs oriented at 0 degrees. The trapezoidal shape indicates that the finger had a broader gripping surface and gradually narrowed towards the base. The ribs, positioned parallel to the finger's longitudinal axis, likely provided structural support and reinforcement. Type 2 Iteration 2 of the gripper finger design featured a trapezoidal cross-section with ribs oriented at +15 degrees. The rib orientation indicated a slight inclination in the direction of the finger's bending motion. Type 2 Iteration 3 of the gripper finger design featured a trapezoidal cross-section with ribs oriented at -15 degrees. The negative rib orientation indicated an inclination in the opposite direction of the finger's bending motion.

3.3 Kinematic Analysis of Soft Gripper

Kinematic analysis is suitable for many applications requiring moving parts since it is easier to do than dynamic

analysis. Kinematic simulations display the actual positions of every component in an assembly in relation to time as it completes a cycle. This technology is valuable for analyzing motion for interference purposes, such as assembly sequences of complicated mechanical systems, as well as for simulating steady-state motion (without acceleration). However, many fundamental kinematic packages go further by offering "reaction forces," or forces that result from the motion.

In this analysis we have done forward kinematic analysis for actuation of single finger of the gripper. There are four links with three revolutionary pair and one prismatic pair as shown in the Figure 17.

$$DOF = 3(n - 1) - 2(l) - h$$

n - No of links; l - No of lower pair; h - No of higher pair,

For our analysis, n = 4, l = 4, h = 0 (Refer Figure 17)

$$DOF = 3(4 - 1) - 2(4) - 0$$

$$DOF = 3(3) - 2(4)$$

$$DOF = 9 - 8$$

$$DOF = 1$$

3.3.2 Grashoff's Criterion

The Grashoff's criterion helps us predict whether a part will return continuously. For the slider crank the Grashoff's criterion is given by

$$l_{min} + e \leq p$$

l_{min} - Length of shortest link, mm; e-Offset distance, mm; p - Length of link 2, mm

For our analysis, $l_{min} = l_1 = 20$; $e = 21$; $p = l_2 = 21$ (Refer Figure 17)

$$20 + 21 \leq 21$$

$$41 \leq 21$$

Therefore, the given chain is Non Grashoff's chain.

3.3.3 Forward Kinematic Analysis

The transformation of coordinates of the end-effector point from the joint space to the world space is known as forward **kinematic** transformation. For the forward kinematics analysis, the one link is fixed, the length of link 2 is considered as l_2 and length of link 3 is considered as l_3 . The offset distance is considered as e and the slider distance from the fixed position is taken as s. The angle θ_2 is given and we will find the value of s.

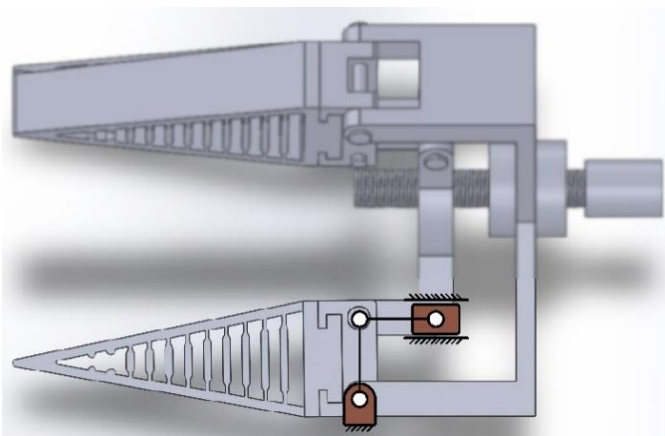

Fig -16: Gripper Line Diagram

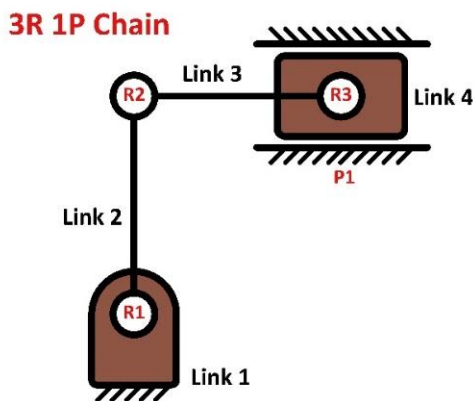

Fig -17: Line Diagram

3.3.1 Degrees of freedom

Degrees of freedom (DOF) is the number of independent variables that define the possible positions or motions of a mechanical system in space. The number of degrees of freedom is equal to the total number of independent displacements or aspects of motion. The formula for calculating the DOF is

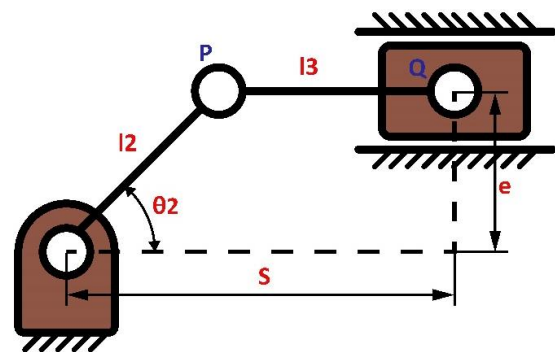

Fig -18: Kinematic Diagram

- Coordinates of P: $(l_2 \cos \theta_2, l_2 \sin \theta_2)$
- Coordinates of Q: (s, e)

Length l_3 can now be expressed as
 $l_3^2 = (s - l_2 \cos \theta_2)^2 + (e - l_2 \sin \theta_2)^2$
 $s^2 + As + B = 0$

$$A = -2l_2 \cos \theta_2,$$

$$B = l_2^2 + e^2 - l_3^2 - 2l_2 e \sin \theta_2$$

$$S = l_2 \cos \theta_2 \pm \text{sqrt} (l_3^2 - (l_2 \sin \theta_2 - e)^2)$$

3.3.4 Analysis of Gripper Actuation

The Actuation system of the soft gripper consists of 4 links with 3 Revolute joints and 1 prismatic joint forming Slider Crank mechanism with 1 Degree of Freedom. Movement from the common drive stepper motor is transmitted to all links of the gripper through kinematic pairs. For kinematic analysis, it is necessary to derive an analytical relationship between the position and orientation of the links of gripper and the generalized coordinate characterizing the position of the group drive.

In this Analysis, we are going to use Forward Kinematics equation which we have derived to find the optimum range for angle of inclination of the gripper and corresponding distance of the slider from the fixed revolute joint (Refer Figure 19 and Figure 20). The Optimum range for angle of inclination of the Gripper finger is between 65 ° and 115 °. And using forward kinematics we can able to find the slider distance. A Graph is plotted between angle of inclination of the gripper and slider distance using MATLAB.

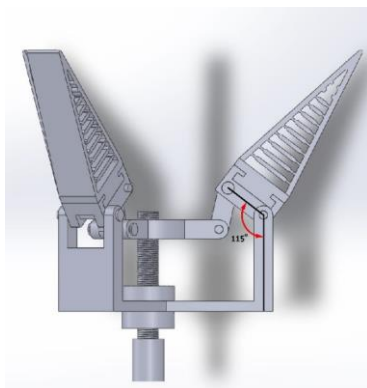

Fig -19: Maximum Angle

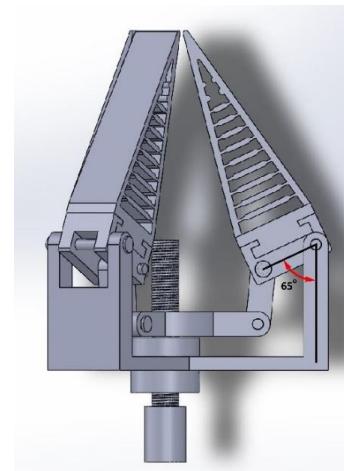

Fig -20: Minium Angle

- Given: θ (65 ° to 115 °)
- To Find: s (Distance of the Slider in mm)

$$s = l_2 \cos \theta_2 \pm \text{sqrt}(l_3^2 - (l_2 \sin \theta_2 - e)^2)$$

Table -1: Angle of Inclination of Gripper and Slider Distance

θ in deg	s in mm
65	28.8
70	27.1
75	25.4
80	23.7
85	21.8
90	20.0
95	18.2
100	16.3
105	14.5
110	12.8
115	11.0

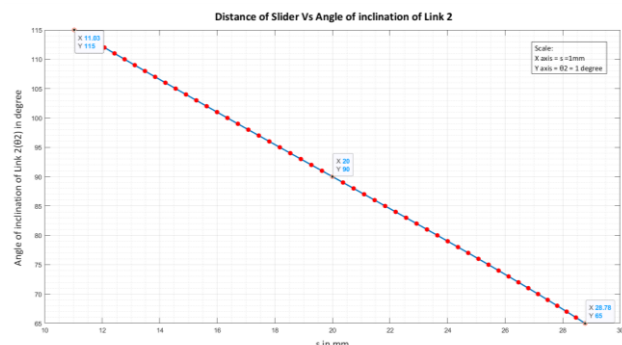

Chart -1: Distance of slider Vs Angle of inclination of Link2 (Gripper)

3.4 Fabrication of Soft Gripper

The most common methods for fabrication of soft grippers are injection molding [14], [9], and 3D printing (FDM) [4], [3]. The production process of casting and molding begins with the creation of the molds using the 3D printing technique, and the molding is subsequently completed [5]. The FDM technology (3D printing) and numerous materials are used in other types of manufacturing to build the gripper [16]. The most popular fin ray effect grippers are 3D printed because of their intricate shape [17]. The fin ray soft gripper is fabricated by 3D printing (FDM) because it had a complex design and several components. Fused Deposition Modelling (FDM) is a type of 3D printing technology that has been widely used in the manufacturing industry. It works by melting a thermoplastic filament and extruding it layer by layer to create a three-dimensional object. Insta bot S1+ is the machine we have used to print both the finger and gripper body using TPU and PLA respectively.

The Gripper fingers are manufactured using TPU 95 A (Thermoplastic Polyurethane). It is a thermoplastic elastomer that is a blend of rubber and plastic. TPU material is tough, flexible, durable and resistant to abrasions like oils and lubricants. The unique blend of rubber and plastic makes it suitable for various applications. TPU provides some extraordinary benefits because of its thermoplastic nature –great load-bearing capacity, high elongation at break, and tremendous tensile strength. The Soft Gripper body is manufactured using PLA (Polylactic acid). It is a type of polymer that can be melted and extruded to create 3D objects layer by layer. PLA Black is a popular choice for 3D printing due to its ease of use, affordability, and versatility. PLA is easy to work with and has good printability. It has a low melting point, which means it requires less heat to melt and has reduced risk of warping during printing, making it suitable for printing intricate and detailed objects.

Properties	Typical Value
Shore Hardness	95
Density	1230 kg/m ³
Ultimate Tensile Strength	45 MPa
Elongation at Break	450 %

Table -2: Properties of TPU

Properties	Typical Value
Density	1340 kg/m ³
Tensile Strength	60 MPa
Elastic modulus	700 MPa
Melting point	220 °C

Table -3: Properties of PLA

The Soft Gripper body is manufactured using PLA (Polylactic acid). It is a type of polymer that can be melted and extruded to create 3D objects layer by layer. PLA Black is a popular choice for 3D printing due to its ease of use, affordability, and versatility. PLA is easy to work with and has good printability.

It has a low melting point, which means it requires less heat to melt and has reduced risk of warping during printing, making it suitable for printing intricate and detailed objects.

4. DEFORMATION TESTING OF GRIPPER FINGER

In this study, nine gripper fingers with varying rib structures and orientations are subjected to deformation testing. The primary focus was to examine the mechanical properties of these fingers and assess how their shapes influenced their performance under different loads. To accomplish this, typical weights such as 50 grams, 200 grams, 500 grams, and 1000 grams were used [4]. The weights were incrementally increased by 50 grams starting from 100 grams. The deflection is measured at the center of each finger as the load was applied. This systematic approach allowed to determine which finger shapes were more susceptible to deformation under different loads and which shapes were more effective. To visualize the response of the finger structures to increasing stress or strain a graph is plotted, load against the corresponding deflections. This graphical representation provided valuable insights into how the finger structures behaved under varying levels of stress. By analyzing the load-deflection plots, the finger shapes that exhibited less resistance to deformation under specific loads and those that displayed better performance can be identified.



Fig -21: Deformation Testing

The graph represents the conclusions drawn from the deflection testing of gripper fingers. The test involved increasing the load on the fingers in increments of 0.5N, starting from 1N and going up to 10N. Standard weights were employed for applying the load. As the load increased, the deflection of the gripper finger's tip showed a gradual rise. However, there was a significant increase in deflection observed after reaching 5N. Among the nine design fingers tested, those with a trapezoidal cross section exhibited the most effective deformation due to the geometric shape of their design. On the other hand, fingers with parabolic and triangular rib structures demonstrated the least deflection. In the case of fingers with a rectangular cross section, higher force was required to achieve effective deflection compared to other designs. Based on these findings, it can be concluded that the shape and geometry of the gripper finger significantly impact its deformation behavior under increasing loads.

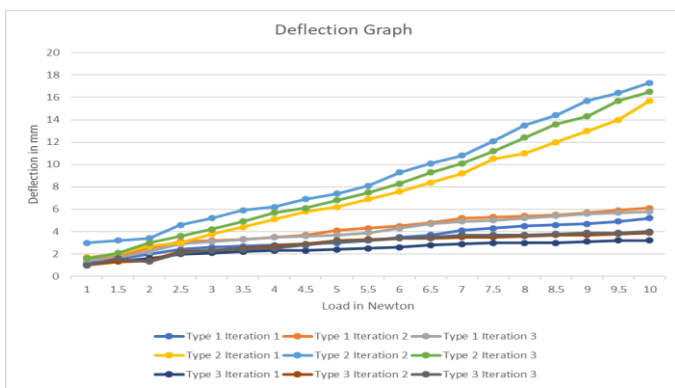

Chart -2: Deformation Testing Results.

From this testing, of Type 2 Iteration 1, Type 2 Iteration 2 and Type 2 Iteration 3 fingers has maximum deflection of 15.7mm, 17.3 mm, 16.5 respectively and proved to be effective.

5. DEFLECTION TESTING OF GRIPPER FINGER

The purpose of the study was to conduct deflection testing on a gripper's finger, with the aim of evaluating its performance when interacting with various objects commonly found in daily life. A total of five objects were randomly selected for this testing. Table 4 lists the name, size, and weight of each object. All items were successfully gripped. They had an average diameter of 70 mm and masses of 57.2g. In this experiment, a soft gripper with three fingers is set up in a stable position to test its ability to grip objects without moving or shifting. Type 2 Iteration 1, Type 2 Iteration 2, Type 3 Iteration 3 Fingers have been selected for this experiment due to their effective deformation. The test objects chosen for this experiment are a tomato, guava, brinjal, biscuits, and a ball. To begin the experiment, a test object (e.g., a tomato) is placed in the gripper so that it is positioned in the center of the fingers. The gripper is then

rotated clockwise by one full rotation (360 degrees). Using a protector, the angle between the gripper fingers and supporting pin is measured, which indicates the deflection of the gripper [4]. The measured deflection in angle (in degrees) is recorded for each rotation. The process is repeated until the gripper has completed 10 full rotations. This incremental testing procedure provides a consistent way to measure the gripper's ability to hold an object in place. After completing the experiment, the recorded data is analyzed to summarize the results. The data analysis includes determining the gripper's maximum deflection capacity and how that capacity changes over time. This information can provide insights into the gripper's performance and its ability to maintain a stable grip on objects. The result of the experiment is tabulated below.

S. No	Object	Diameter(mm)	Weight (g)
1	Tomato	60	76
2	Guava	90	105
3	Brinjal	60	40
4	Ball	75	60
5	Biscuit	60	5

Table -4: Sample Objects

The graph is plotted for normal environment, But the gripper's performance was tested in three different environments: normal, humid, and dusty. The normal environment represents the standard conditions without any changes to the environment properties. In this case, the objects used in the experiment were not damp or dusty. The humid environment was created by moistening both the gripping tool and the test objects. The presence of humidity had varying effects on different objects depending on their surface properties and the degree to which they could absorb moisture. For example, a plastic container with smooth walls might experience only minor effects from the humid environment. On the other hand, a sponge, with its higher water absorption and surface adhesion properties, would be significantly impacted in such an environment. The dusty environment was simulated by applying a generous amount of flour to both the gripper and the test objects. This situation represents conditions that can be encountered in agriculture or specific industrial processes. By conducting the experiment in these three different environments, it was possible to assess the gripper's performance under varying conditions and evaluate its ability to maintain a stable grip on objects in different scenarios. The data collected from each environment can provide insights into how the gripper performs under realistic conditions and help identify any limitations or improvements needed for its functionality in specific applications.

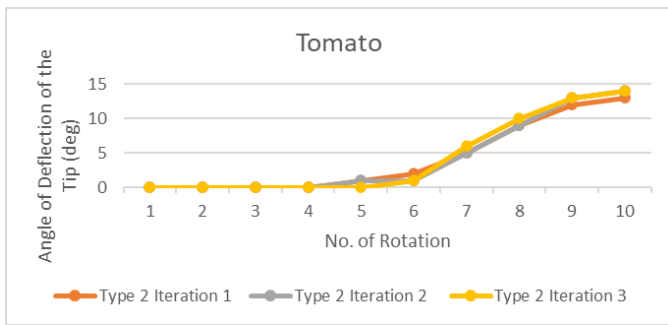

Chart -3: Tomato

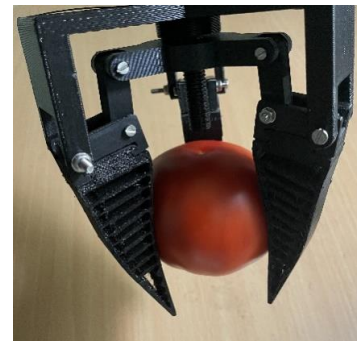

Fig -22: Tomato

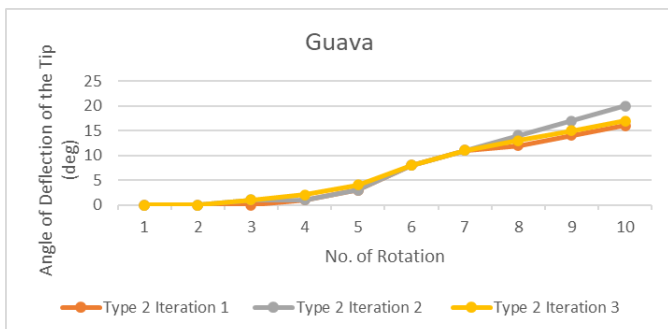

Chart -4: Guava



Fig -23: Guava

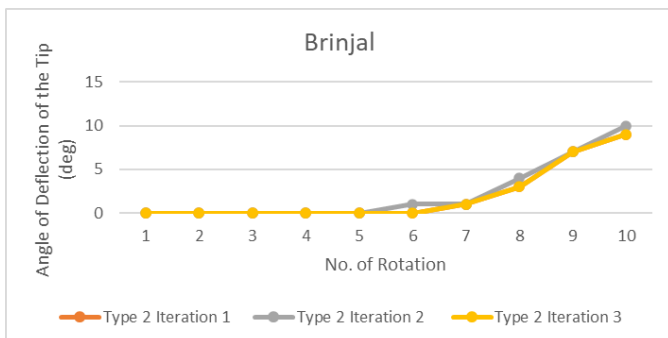

Chart -5: Brinjal



Fig -24: Brinjal

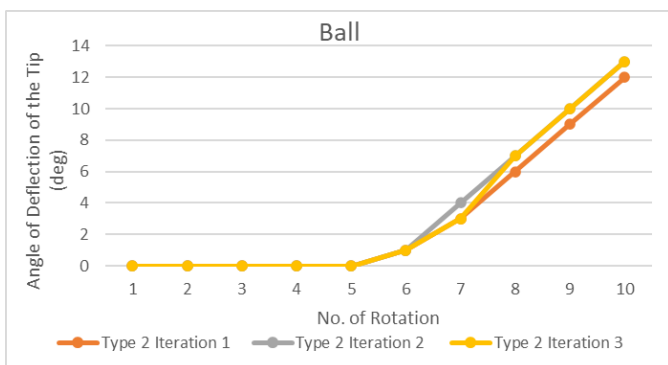

Chart -6: Ball.

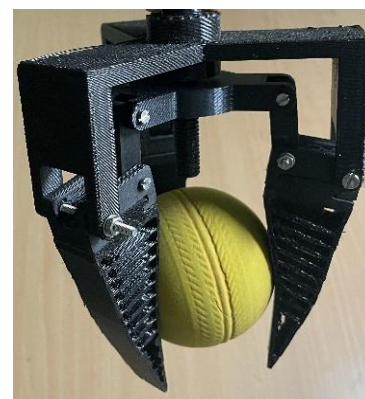

Fig -25: Ball

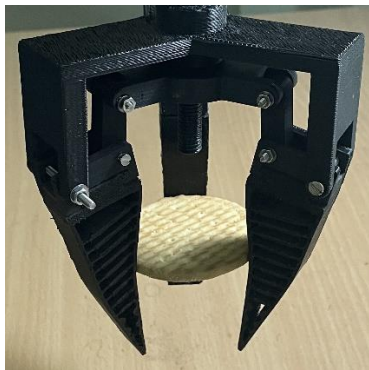

Fig -26: Biscuit

The Above graph is plotted for normal environment, But the gripper's performance was tested in three different environments: normal, humid, and dusty. The normal environment represents the standard conditions without any changes to the environment properties. In this case, the objects used in the experiment were not damp or dusty. The humid environment was created by moistening both the gripping tool and the test objects. The presence of humidity had varying effects on different objects depending on their surface properties and the degree to which they could absorb moisture. For example, a plastic container with smooth walls might experience only minor effects from the humid environment. On the other hand, a sponge, with its higher water absorption and surface adhesion properties, would be significantly impacted in such an environment. The dusty environment was simulated by applying a generous amount of flour to both the gripper and the test objects. This situation represents conditions that can be encountered in agriculture or specific industrial processes. By conducting the experiment in these three different environments, it was possible to assess the gripper's performance under varying conditions and evaluate its ability to maintain a stable grip on objects in different scenarios. The data collected from each environment can provide insights into how the gripper performs under realistic conditions and help identify any limitations or improvements needed for its functionality in specific applications.

5.1 Wrap Around Grasping

Wrap-around grasping is a technique commonly employed by soft grippers to securely grasp objects with irregular shapes or varying sizes. In this approach, the soft fingers of the gripper wrap around the object, conforming to its contours and providing a more customized grip. The inherent flexibility and compliance of the gripper's material enable it to adapt to the object's shape, ensuring a stable and reliable grasp. This wrap-around grasping technique is particularly advantageous when dealing with objects that are difficult to handle using rigid grippers, as it enhances the gripper's ability to maintain a secure hold on objects of diverse geometries, ultimately expanding its applicability in various industries such as manufacturing, robotics, and

automation. Our Fin Ray gripper has effective wrap around grasping capabilities.

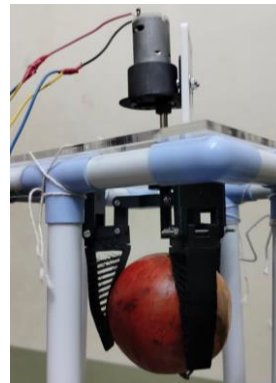

Fig -26: Pomegranate



Fig -27: Mango



Fig -28: Egg



Fig -29: Apple

5.2 Pinch Grasping

Pinch grasping is another common technique employed by soft grippers to achieve a secure grip on objects. In pinch grasping, the soft fingers of the gripper come together to form a pinch-like configuration, mimicking the action of human fingers. By bringing the fingers closer, the gripper can exert pressure on the object, creating a firm hold. The Fin ray soft gripper can able to pinch grasp object effectively.

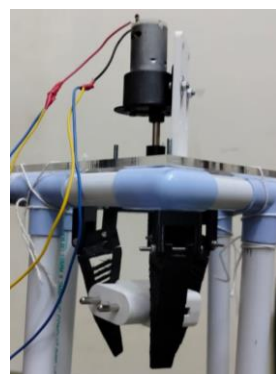

Fig -30: Mobile Charger

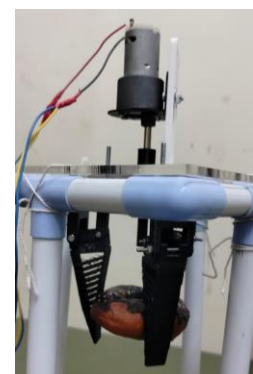

Fig -31: Donut

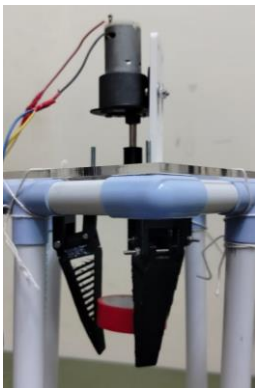

Fig -32: Tape

Fig -33: Cap

6. CONCLUSION

This article presents the development of a fully 3D printed soft robotic gripper that leverages the Fin Ray effect, enabling it to grasp objects with diverse characteristics, such as varying weights, shapes, and stiffnesses. The gripper was fabricated using a cost-effective and open-source fused deposition modeling (FDM) 3D printer. The gripping fingers were manufactured using thermoplastic polyurethane (TPU), while the rigid gripper body was made of polylactic acid (PLA). To optimize the bending behavior and conformability of the gripper, we have designed nine fingers with different rib structures and orientations.

Finite element method (FEM) simulations were employed to evaluate the fin-ray structure's performance, and fingers with trapezoidal cross sections were found to be effective based on these simulations. Additionally, forward kinematic analysis is conducted to accurately track the gripper's motion. Deformation and deflection testing were performed to evaluate the performance of the fingers, with the trapezoidal rib structure resulting in the highest deflection and deformation. The designed fin ray soft gripper proved to be effective in both wrap around grasping and pinch grasping. Furthermore, the gripper's performance was assessed in normal, humid, and dusty environments. When in contact with an object, the finger structure inspired by fish fins can passively adapt itself to match the object's profile. This inherent safety feature makes it suitable for various scientific research and service applications involving human interaction. The gripper's soft material and elastic structure also enable it to handle excessive external forces without damaging the objects, making it ideal for non-destructive gripping. By employing a single gripper that can adapt to different object shapes without requiring changes or reprogramming, time and cost can be saved when grasping objects with various shapes in a production line. Furthermore, the gripper can be integrated into intelligent assembly systems, automatic sorting processes, logistics and warehousing operations, food processing lines, as well as agricultural and harvesting applications.

REFERENCES

- [1] D Shintake, J., Cacucciolo, V., Floreano, D. and Shea, H., 2018. Soft robotic grippers. *Advanced materials*, 30(29), p.1707035.
- [2] Terrile, S., Argüelles, M. and Barrientos, A., 2021. Comparison of different technologies for soft robotics grippers. *Sensors*, 21(9), p.3253.
- [3] Yang, Y., Jin, K., Zhu, H., Song, G., Lu, H. and Kang, L., 2021. A 3D-printed fin ray effect inspired soft robotic gripper with force feedback. *Micromachines*, 12(10), p.1141.
- [4] Shin, J.H., Park, J.G., Kim, D.I. and Yoon, H.S., 2021. A universal soft gripper with the optimized fin ray finger. *International Journal of Precision Engineering and Manufacturing-Green Technology*, 8, pp.889-899.
- [5] Liu, C.H., Chung, F.M., Chen, Y., Chiu, C.H. and Chen, T.L., 2020. Optimal design of a motor-driven three-finger soft robotic gripper. *IEEE/ASME Transactions on Mechatronics*, 25(4), pp.1830-1840.
- [6] Elgeneidy, K., Lightbody, P., Pearson, S. and Neumann, G., 2019, April. Characterising 3D-printed soft fin ray robotic fingers with layer jamming capability for delicate grasping. In *2019 2nd IEEE International Conference on Soft Robotics (RoboSoft)* (pp. 143-148). IEEE.
- [7] Ali, M.H., Zhanabayev, A., Khamzhin, S. and Mussin, K., 2019, April. Biologically inspired gripper based on the fin ray effect. In *2019 5th International Conference on Control, Automation and Robotics (ICCAR)* (pp. 865-869). IEEE.
- [8] Tawk, C., Gao, Y., Mutlu, R. and Alici, G., 2019, July. Fully 3D printed monolithic soft gripper with high conformal grasping capability. In *2019 IEEE/ASME International Conference on Advanced Intelligent Mechatronics (AIM)* (pp. 1139-1144). IEEE.
- [9] Crooks, W., Vukasin, G., O'Sullivan, M., Messner, W. and Rogers, C., 2016. Fin ray® effect inspired soft robotic gripper: From the robosoft grand challenge toward optimization. *Frontiers in Robotics and AI*, 3, p.70.
- [10] Shan, X. and Birglen, L., 2020. Modeling and analysis of soft robotic fingers using the fin ray effect. *The International journal of robotics research*, 39(14), pp.1686-1705.
- [11] Basson, C.I. and Bright, G., 2018. Active haptic control for biologically inspired gripper in reconfigurable assembly systems. In *International conference in informatics in control, automation and robotics, ICINCO, Porto* (pp. 91-100).

- [12] Deng, Z. and Li, M., 2021. Learning optimal fin-ray finger design for soft grasping. *Frontiers in Robotics and AI*, p.161.
- [13] Terrile, S., Argüelles, M. and Barrientos, A., 2021. Comparison of different technologies for soft robotics grippers. *Sensors*, 21(9), p.3253.
- [14] Subramaniam, V., Jain, S., Agarwal, J. and Valdivia y Alvarado, P., 2020. Design and characterization of a hybrid soft gripper with active palm pose control. *The International Journal of Robotics Research*, 39(14), pp.1668-1685.
- [15] Wang, Z., Chathuranga, D.S. and Hirai, S., 2016, December. 3D printed soft gripper for automatic lunch box packing. In *2016 IEEE International Conference on Robotics and Biomimetics (ROBIO)* (pp. 503-508). IEEE.
- [16] Wang, Z., Torigoe, Y. and Hirai, S., 2017. A prestressed soft gripper: design, modeling, fabrication, and tests for food handling. *IEEE Robotics and Automation Letters*, 2(4), pp.1909-1916.
- [17] Wang, Z., Or, K. and Hirai, S., 2020. A dual-mode soft gripper for food packaging. *Robotics and Autonomous Systems*, 125, p.103427.