

## 2 in 1 LASER Engraving & CNC Cutting Machine

Arpita Shukla<sup>1</sup>, Aliya Sayyad<sup>2</sup>, Janvi Wagh<sup>3</sup>, Kalash Khante<sup>4</sup>, Sakshi Gonde<sup>5</sup>, Vikas Yadav<sup>6</sup>,  
Prajakta Upadhyay<sup>7</sup>

<sup>1,2,3,4,5,6</sup> Student, Electronics & Telecommunication Engineering Department, G H Rasoni Institute of Engineering & Technology, Nagpur-440023

<sup>7</sup> Professor, Dept. of Electronics & Telecommunication Engineering, G H Rasoni Institute of Engineering & Technology, Nagpur-440023, Maharashtra, (India)

\*\*\*

**Abstract** – This Paper is proposed to design a new integration of laser Engraver and CNC Cutting Machine is useful in many Domain. In this we have tried to Build an effective machine in which two separate mechanism are brought together within minimum components and less Costing. This also involves the suction part to keep the surface that has to worked on in one place. Also the software that are used as a open source and can be interchanged, saving the purchasing cost of software.

**Key Words:** Computer Numerical (CNC), Laser Engraver, Cutting Machine, Stepper Motor, Vertical Drill Machine, Suction.

### 1. INTRODUCTION

Laser (Light Amplification by Stimulated Emission of Radiation) is a device that generates high intensity light in the form of laser beam. The output light is generated by stimulated emission of radiation and photons emitted by laser light are also in phase. The idea of laser was generated/invented by Albert Einstein in 1917 and finally in 1963 CO<sub>2</sub> laser that is carbon dioxide laser was developed. CO<sub>2</sub> laser has much lower cost and higher efficiency. These factors have made it most popular industry laser type for more than 50 years and the laser used in our project is CO<sub>2</sub> laser.

Basically, in LASER engraving, the laser beam burns the top layer of the surface to be engraved. The burnt area is left uncolored, which makes it appear different from the surrounding surface. In the laser engraving process, a laser beam physically removes the surface of the material to expose a cavity that reveals an image when looked at it. During the engraving process, the laser beam creates high heat, which essentially causes the material to vaporize. This creates a cavity in the surface of the material (Wood, cardboard, etc) that is noticeable and used for cutting the papers as per the profile created by the laser beam movement. Several passes are to be done to get deeper marks during the engraving process.

### 2. SYSTEM CONFIGURATION

This system is an integrated system of Vertical Drill machine, laser cutting and Laser engraving Machine.

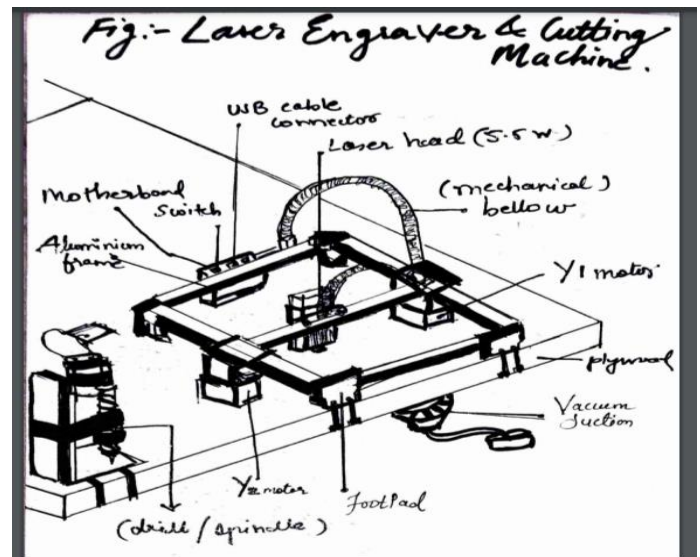

**Fig -1:** An Integrated system of Vertical Drill machine, laser cutting and Laser engraving Machine.

#### 2.1 LASER Engraver

Engraving is a process of design onto a hard surface by cutting grooves into it, basically on flat surface oriented perpendicular to the processing beam axis. Engraving was very important method of producing image on paper like printmaking, in mapmaking and also for book and magazine. This is replaced by etching and other technique because of difficulty of learning the technique. Modern engraving technique such as laser engraving and 3 photoengraving have many important application. Laser engraving is one of the most suitable technologies to be used in wood engraving operation. In this method a laser beam is used to penetrate the solid material.

The advantage of this laser is non-contact working, high scanning speed, high flexibility and high automation.

CNC (Computer Numerical Control) technology is often used in laser engraving machines to precisely control the movement and positioning of the laser beam. A laser engraving machine is a device that uses a high-powered laser beam to etch or engrave a design, pattern, or text onto various materials.

In this CO2 lasers (5.5 watt laser) are commonly used for engraving, where the laser beam burns the surface, creating uncoloured areas that form an image.

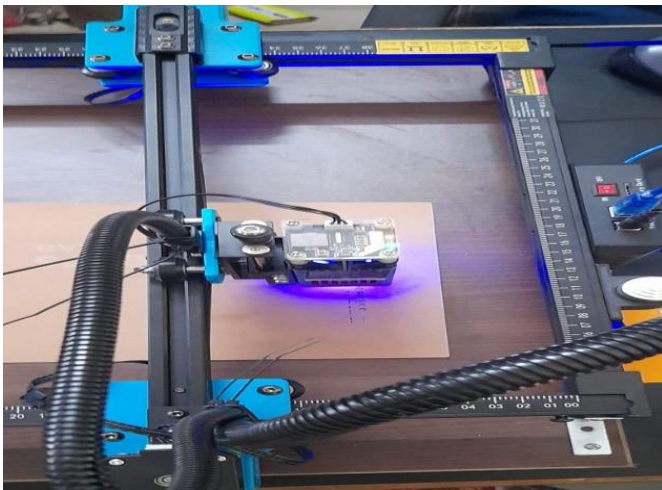

Fig-2[1]: Laser Engraving Machine

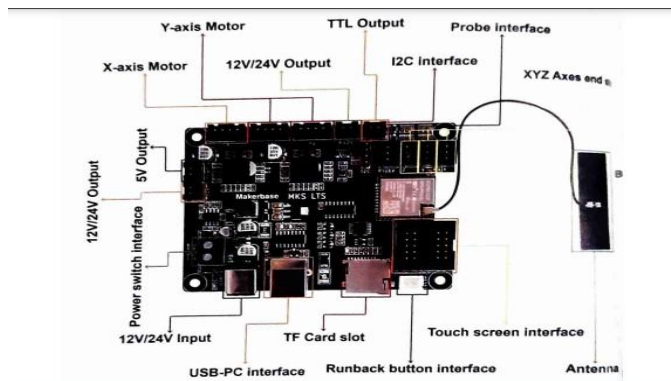

Fig-2[2]: Circuit and Connecting Diagram of laser Engraver

## 2.2 Vertical Drill Machine

Drilling machines are designed to produce accurate and precise holes that are consistent in size and depth. They can drill holes much faster than a manual drill.

As some of the machines are automated, they can produce a large number of holes that are consistent in size, shape, and depth. They can be used to drill for a variety of materials, including metal, wood, plastics, and composites, making them versatile tools for a range of industries and applications.

It is designed for drilling small holes at high speeds in light jobs. High speed and hand feed are necessary for drilling small holes. The base of the machine is mounted either on a bench or on the floor by means of bolts and nuts. It can handle drills upto 15.5mm of diameter. The drill is fed into the work purely by hand. The operator can sense the progress of the drill into the work because of hand feed. The machine is named so because of this reason.

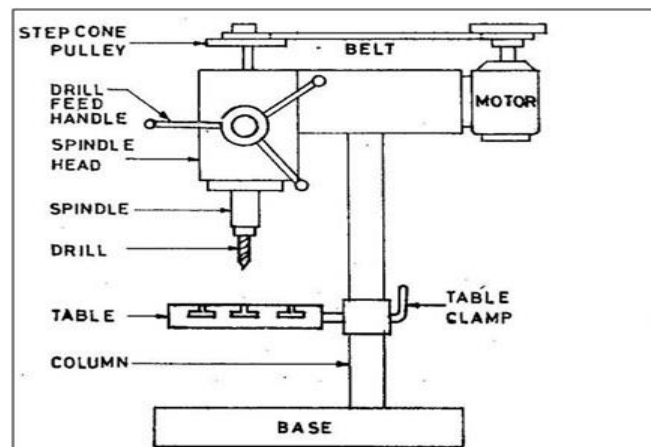

Fig-2[3]: Vertical Drill Machine

## 2.3 LASER Cutting Machine

Laser beam cutting is well-established and effective method of cutting a wide range of material. In recent time technological advancement can be seen in every area. Laser cutting works by concentrating a high power pulsed laser at a specific location on the material to cut. The energy beam is absorbed into the surface of the material and the energy of the laser is converted into the heat, which melt or vaporize the material.

Advantages of Laser cutting

1. Edges are clean with no burn and dust formation.
2. High level of precision and accuracy of cut line.
3. No material deformation due to contactless processing.
4. Cutting of material of various thickness and combinations in one go.
5. No tooling cost.

Disadvantages of Laser cutting

1. Creation rate is not dependable when laser cutting is used. It will depend by and large on the thickness of the workpiece, the kind of material used and the method for laser cutting.

2. Carelessness in altering laser division and temperature may provoke replicating of a couple of materials. Certain metals tend to stain if the power of the laser shaft is not as per need.

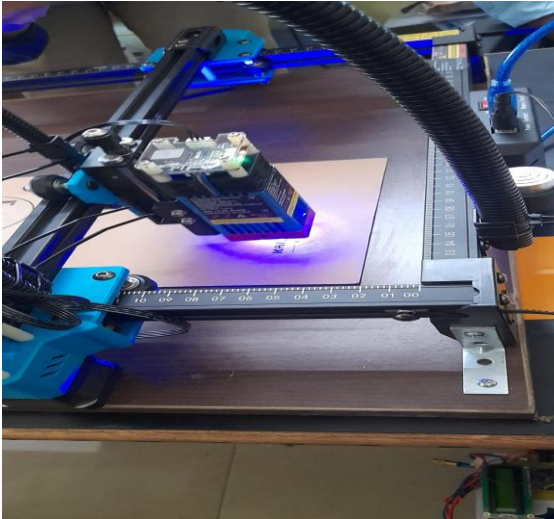

Fig-2[4] : LASER Cutting Machine

### 2.4 Suction

Vacuum suction in a cutting machine refers to the use of a vacuum system to hold materials in place during the cutting process.

The primary purpose of suction in a laser engraving machine is to remove smoke, fumes, and debris generated during the engraving or cutting process. Here's how suction is used in laser engraving machines.

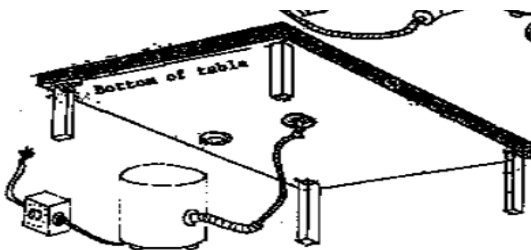

Fig-2[5]: Suction used in laser engraver & laser cutting Machine to hold on the material onto one place.

### 3.SOFTWARE

The development machine is a digital manufacturing system which usually depends upon the software to generate an executable code, i.e , G-Code, based on given computer models. Laser engraver and laser cutting machine relay on same software called LASER GRBL is one of the most popular laser engraving software.

### 3.1 Instruction of using LASER GRBL

Step 1-Download the software.

Step 2-Software Installation.

Step 3-Setup the language.

Step 4-Load Engraving File .

Step 5-Set picture parameters , engraving mode and engraving quality.

Step 6-Set engraving speed ,engraving energy and engraving size

Step 7-The input is engraved on the material

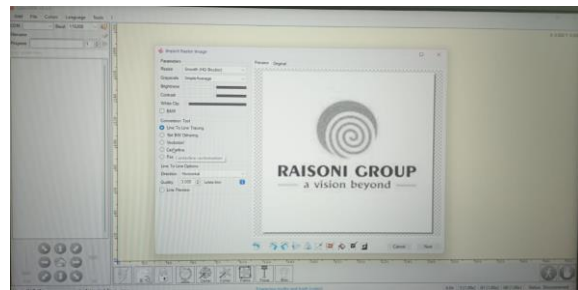

Fig-3[1]: load Engraving File



Fig-3[2]: Set picture parameters, engraving Mode and engraving quality



Fig-3[3]: Set engraving speed, engraving energy and engraving size



Fig-3[4]: LASER Engraving on cardboard

### 3.2 Flow Chart of LASER Engraver Working

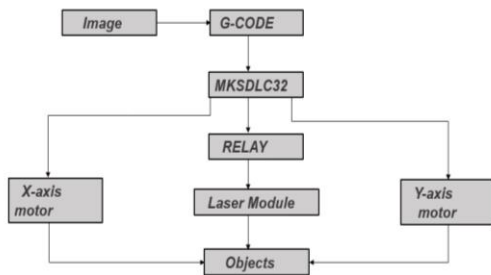

Fig-3[5]: Working Flow Chart

## 4. ANALYSIS & RESULTS

### 4.1 Analysis

By varying the processing parameters of laser engraving and cutting such as speed, energy, size different shapes can be created on the surface.

#### For Engraving:-

Material	Speed(mm/min)	Power (%)	Times
Plywood	2000	50	1
Acrylic	6000	30	1
Leather	6000	80	1
Electroplating coating	300	100	1
Powder coating	5000	50	1
Anodic alumina	4000	70	1
Stainless steel	1200	100	1
MDF	5000	40	1
Pedicle	2000	100	1
Plastic sheet	6000	80	1
Cardboard	5000	80	1

#### For Cutting:-

Material	Speed(mm/min)	Power (%)	Times
Plywood 1-3mm	150-300	100	1-2
Plywood 4mm	100	100	2-3
Acrylic 1mm	150	100	1
Acrylic 2mm	150	100	1
Kraft cardboard	1000	100	1
Leather	500	100	1

Table -1: Testing Machine on different Object

### 4.2 Results

1. Accuracy and Precision: We are expecting the machine to work with almost 60%-70% of accuracy.

2. Software Functionality: The software that we have preferred is Laser GRBL.

3. Safety Measures: As we are dealing with high power laser the most important safety measure is do not go for any direct contact with it and use protective goggles most preferable. Also it is needed to understand the working and actual settings of the software beforehand actual work.



Fig-4[1]: Laser Engraving on paper



Fig-4[2]: Laser Engraving on Metal

## 5. CONCLUSION

The concept was converted into reality along with all its components. It was found out during the conducted experiments that laser is working properly on cardboard, paper, metal as per design. Similarly, LASER cutting machine & Vertical drill machine also working properly. The size of a platform can be increased for bigger projects on the future.

The Engraver is a practical digital system, just like laser cutting machine. It is a programmable machine, By sending G-Code commands, users can control the machine digitally or manually.

#### Advantage:

- Low weight
- Low cost
- Easily transportable
- Easy setup

#### Disadvantages:

- Available for only soft material
- Works only with D.C supply.

## 6. REFERENCE

1. International Journal of Analytical, Experimental and Finite Element Analysis Volume 8, Issue 3, July 2021, pp 76 - 81 <https://doi.org/10.26706/ijaefea.3.8.2021070276> Int. J. of Analytical, Experimental and Finite Element Analysis [www.ame.org.in](http://www.ame.org.in) Dr . Abhinav P. Ninawe Vijeet Khadilkar [vijeetkhadilkar@gmail.com](mailto:vijeetkhadilkar@gmail.com) Mohammed Muzammil [muzzu3952@gmail.com](mailto:muzzu3952@gmail.com) Nihal Mankar Yash Tiwari Ankit Thakre Department of Mechanical Engineering, KDK College of Engineering, Nagpur, India Design and Development of CNC Foam Cutter.

2. Jayaprasad V C, G Sahajananda , Lohith K S, Harishankara P, Karthik. S UG students & Assistant Professor School of Mechanical Engineering. REVA University , Bengaluru , “Design and Development of CNC Based Laser Engraver”.

3. “The Possibility of Creating a Low-Cost Laser Engraver CNC Machine Prototype with Platform” Arduino Štefan Koprda<sup>1</sup> , Zoltán Balogh<sup>1</sup> , Martin Magdin<sup>1</sup> , Jaroslav Reichel<sup>1</sup> , György Molnár<sup>2</sup> .

4. Laser Engraving: Engraving at the Speed of Light

- Spence, J. Stephen (Author)
- English (Publication Language)
- 258 Pages - 09/13/2019 (Publication Date) .
- 

5. Laser Engraving: Guide to Using Scarve Engraving Software

- Talbott, Douglas (Author)
- English (Publication Language)
- 59 Pages - 09/02/2017 (Publication Date) .

6. “Manufacturing System Design of a CNC Laser Engraver”.