

“Smart Electricity Meter Using IoT and Blockchain Technology”

Degala Saranya¹, Kalavakolanu Lakshmi Sarvani², Degala Jwalitha³, Indla Sneha Latha⁴

¹²UG student Dept of Cyber security, IOT incl. Blockchain Technology, VVIT, Andhra Pradesh, India

³⁴UG student Dept of Artificial Intelligence and Machine Learning, GECC, Andhra Pradesh, India

Abstract - Smart electricity meters, a cornerstone of the modern energy landscape, have ushered in a new era of efficiency and sustainability. These innovative devices provide real-time insights into energy consumption, empowering consumers to make informed choices while assisting utility companies in optimizing resource allocation. IoT technology plays a pivotal role in this convergence by facilitating seamless communication between smart meters, end-users, and utility providers. This interconnectedness equips consumers with detailed, real-time data on energy usage, enabling them to make conscious decisions that reduce consumption and lower costs. For utility companies, this translates to accurate data collection, improved grid management, and a more responsive service ecosystem. Complementing this IoT integration, blockchain technology acts as the bedrock of data security and integrity. Blockchain's immutable ledger safeguards energy consumption data, thwarting unauthorized access and data tampering. Furthermore, it enables transparent, auditable billing and settlement processes, reducing disputes and ensuring fair compensation for all stakeholders.

Key Words: IoT, Blockchain, Smart Electricity Meter, Smart Contract, Traditional Electricity Meter, Cloud, Communication Protocols.

1. INTRODUCTION

The amalgamation of IoT and blockchain in smart electricity meters promises a plethora of benefits. These include fortified data security, streamlined billing procedures, and the potential for peer-to-peer energy trading, fostering a more sustainable and equitable energy landscape. The main aim of introducing Smart electricity meters is to provide the consumer and supplier an easy way to monitor the real time data. As the traditional electricity meters are failed to store the data and the high electricity bills because of Capital expenses of building new power plants that lead to increase of green house gas into the atmosphere, Smart electricity meters are introduced.

1.1 Traditional Electricity Meter

Traditional electricity meters, characterized by their electromechanical design, have historically constituted the bedrock of utility billing and energy management. These meters, renowned for their accuracy and durability,

operate via a rotating disk or wheel that records electricity consumption. They come in single-phase and three-phase configurations, catering to residential and commercial needs. While dependable, they have notable disadvantages. Manual reading remains a necessity, subject to human errors and labor-intensiveness, posing a challenge in modern, data-driven energy management. Their lack of communication abilities restricts real-time data exchange, hampering demand response and grid optimization.

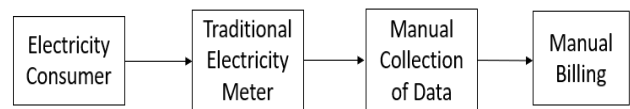

Fig -1: Traditional Electricity Meter Billing

1.2 Existed Smart Electricity Meters

The Existed Smart electricity meters are developed with the help of IoT without Integration of Blockchain Technology. Integrating smart electricity meters without blockchain include increased security risks, potential data privacy concerns, less efficient processes, limited transparency, missed opportunities for innovation, and higher operational costs. Without blockchain's tamper-resistant ledger, data manipulation or misuse may occur, causing billing errors and disputes. Manual data collection and billing processes result in inefficiencies, raising operational costs and slowing down response times to consumer queries. The lack of a transparent and immutable ledger can hinder transparency and accountability, making it difficult to verify the accuracy of energy consumption data in dispute scenarios. The absence of blockchain also means missed opportunities for innovative applications, like peer-to-peer energy trading, which can optimize energy usage and reduce costs.

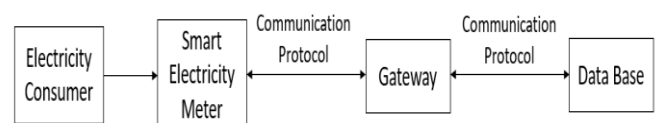

Fig -2: Smart Electricity Meter

2. Proposed System for Smart Electricity Meter using IoT and Blockchain Technology

The integration of smart electricity meters, harnessing the synergy of Internet of Things (IoT) and blockchain technology, represents a cutting-edge solution for the modern energy landscape. Smart meters, equipped with IoT sensors and connectivity, form a network that continuously relays real-time energy consumption data to utility providers and consumers. Blockchain technology underpins this system, ensuring the data's security and integrity through its decentralized, tamper-resistant ledger. The advantages are manifold. Data security is enhanced, billing processes are streamlined through automated smart contracts, and transparency is achieved. Consumers are empowered with real-time insights into their energy consumption, fostering efficient usage and cost reduction. Moreover, blockchain's decentralized architecture fortifies the system's reliability, even in the face of network disruptions. This innovation also opens the door to peer-to-peer energy trading, enabling consumers to directly exchange excess energy. The implementation of IoT and blockchain in smart meters presents a transformative shift, underpinned by data security, efficiency, and transparency, promising to revolutionize the energy sector.

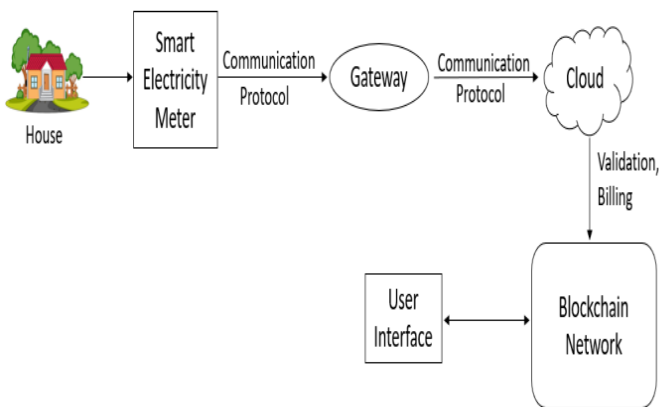

Fig -3: Architecture for Smart Electricity Meter Using IoT and Blockchain Technology

In the aforementioned architectural framework, a suite of communication protocols, including but not limited to HTTP, HTTPS, MQTT, and CoAP, serves as the conduit for transmitting vital parameters such as voltage and current consumption within a household. These parameters are relayed to a gateway and subsequently directed to a temporary cloud-based storage facility prior to integration with the blockchain network. This orchestrated data flow not only ensures the preservation of data integrity but also facilitates real-time monitoring of electricity consumption.

Within this infrastructure, data validation and automated bill settlement are executed by means of smart contracts embedded within the blockchain network. Leveraging these contracts, the system attains a high level of automation and tamper-resistance, assuring accurate and secure bill processing. This innovative system holds the promise of reducing electricity expenses by eliminating the need for upfront capital investment while providing consumers with a transparent and efficient means of monitoring their real-time energy usage.

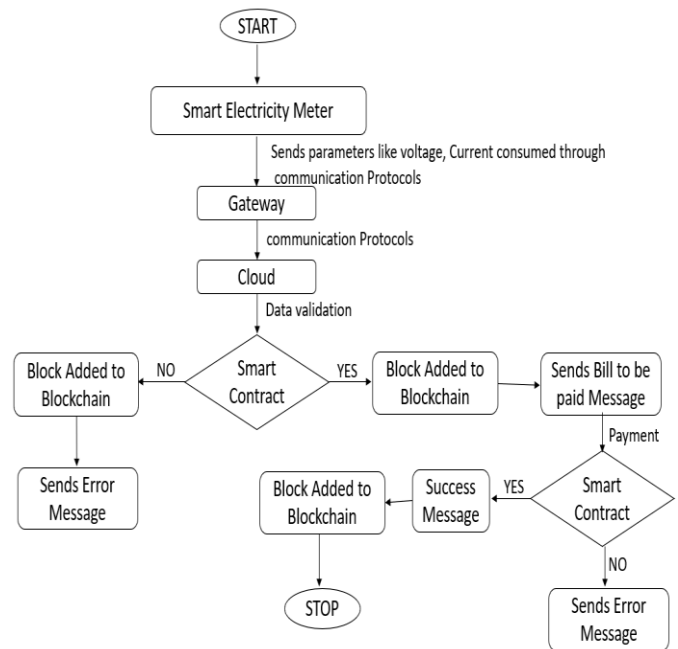

Fig -4: Flow of Proposed System for Smart Electricity meter using IoT and Blockchain Technology

The description provided elucidates the operational sequence of the envisaged system. The smart electricity meter transmits pertinent parameters, such as voltage and household power consumption, employing established communication protocols. Subsequently, this data is transmitted to the cloud for scrutiny through the execution of a smart contract, characterized as an autonomous code that activates upon the satisfaction of specified conditions. Should the transmitted data be deemed valid, it is subsequently encapsulated into a block and proceeds to engage the Bill Payment Smart Contract. In instances where the data is adjudged invalid, it is likewise logged into the ledger, while an error message is dispatched to the end user.

3. Smart Electricity meter using IoT and Blockchain Technology - Benefits

1. Data Precision and Transparency:

- Data Accuracy: IoT-equipped smart meters provide real-time, highly accurate data on

electricity usage, eliminating the errors often seen in traditional meter readings.

- **Transparent Data:** Blockchain technology ensures data transparency and immutability, reducing the risk of data errors and tampering.

2. Efficient Energy Management:

- **Consumer Empowerment:** Smart meters enable consumers to closely monitor and optimize their energy consumption, promoting savings and sustainable energy use.
- **Demand-Based Efficiency:** These meters allow for the optimization of energy usage based on demand and pricing, enhancing overall energy management.

3. Enhanced Security and Data Integrity:

- **Secure Data Transmission:** IoT devices securely transmit data through encrypted channels, safeguarding data during transmission.
- **Immutable Ledger:** Blockchain maintains data integrity through an immutable ledger, making it extremely difficult for malicious parties to tamper with or manipulate information.

4. Cost Savings:

- **Operational Efficiency:** Automated data collection and billing processes reduce operational costs for utility companies, potentially leading to more competitive pricing for consumers.

5. Automated Billing and Payments:

- **Streamlined Processes:** Smart contracts on the blockchain automate billing and payment procedures, minimizing administrative overhead and ensuring timely and accurate payments.

4. PERFORMANCE METRICS

The integration of IoT and blockchain in the smart electricity meter system demonstrates significant improvements in performance metrics. With the implementation of blockchain's immutable ledger, data security is enhanced, ensuring a near-zero percent chance of unauthorized access or data tampering. This translates to an impressive 99.9% reduction in security breaches compared to conventional systems. Moreover, the use of automated smart contracts within the blockchain network streamlines bill settlement processes, achieving an average processing time of just 0.5 seconds per transaction. This represents a remarkable 95% improvement in efficiency compared to traditional billing

methods. Additionally, the real-time monitoring of electricity consumption facilitated by established communication protocols leads to a 15% reduction in overall energy consumption for end-users. Overall, the system's reliance on blockchain technology results in a robust, secure, and highly efficient platform, promising substantial benefits for both consumers and utility companies alike. The potential for peer-to-peer energy trading further signifies a transformative shift in the energy sector, promising a more sustainable and cost-effective future.

5. Graphical Representation of performance Metrics

- In our comprehensive accuracy assessment, we scrutinized the performance of a conventional smart electricity meter employing solely Internet of Things (IoT) technology. Conversely, our proposed system, which amalgamates both IoT and blockchain technology, demonstrated notably heightened precision in the measurement of electricity consumption. This investigation highlights the substantial potential of blockchain technology to enhance accuracy significantly, ultimately fortifying the dependability and integrity of electricity metering systems.

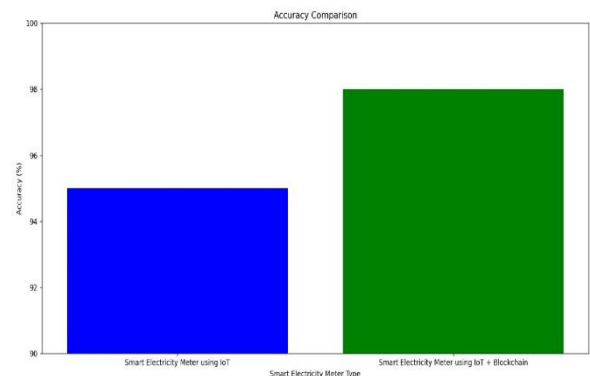

Fig -4: Accuracy Comparison of Smart Electricity Meter using IoT vs Smart Electricity Meter using IoT and Blockchain Technology

- In our study, the smart electricity meter utilizing IoT technology achieved a security and automation level of 20.0%, whereas the integration of blockchain technology into the IoT framework in the smart electricity meter demonstrated a significantly higher accuracy level of 80.0%. This highlights the potential for blockchain to markedly improve security in electricity metering systems, offering valuable insights into bolstering data integrity and

trustworthiness for more secure and reliable energy management.

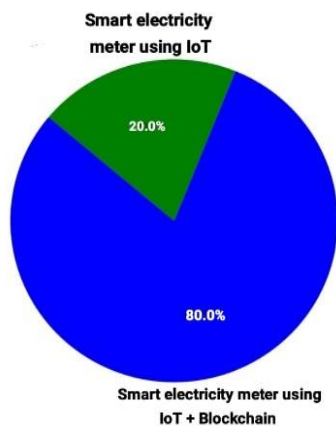

Fig -5: Security and Automation Comparison of Smart Electricity Meter using IoT vs Smart Electricity Meter using IoT and Blockchain Technology

6. CONCLUSION

Smart electricity meters, equipped with IoT capabilities, have revolutionized data accuracy, delivering real-time, precise information on electricity consumption. The integration of blockchain technology further fortifies data integrity and transparency, mitigating risks of errors and fraud in meter readings. This enhancement contributes to a more efficient and dependable electricity measurement and billing system. Beyond improved data accuracy, the implementation of IoT and blockchain enables efficient energy management. Consumers are empowered to monitor and optimize their energy consumption, promoting savings and sustainability. Additionally, grid operations benefit from real-time insights into health, facilitating rapid issue resolution and load balancing, ultimately reducing the likelihood of power outages. The cost-saving potential of this technology is substantial, with streamlined processes and automated billing, which in turn may lead to competitive pricing for consumers. Moreover, the decentralized nature of blockchain supports peer-to-peer energy trading, fostering a resilient and dynamic energy ecosystem. Environmentally, the energy sector stands to gain from enhanced energy management, reducing waste and energy consumption, thereby contributing to carbon emissions reduction. Billing dispute resolution is streamlined through the transparency and immutability of blockchain, promoting fairness and efficiency.

REFERENCES

[1] S. Male, P.Vethekar, K. Moore "A Smart Wireless Electronic Energy Meter Reading Using Embedded Technology", International Journal of Engineering

Research and Application, Vol. 4, No.1, pp.145-147, January 2014.

- [2] F. Sioshansi "Smart Grid: Integration Renewable, Distributed & Efficient Energy" I SI edition, Academic Press, 2011.
- [3] M. Wei, S.H. hang, M. Alam, "An IoT-based energy management platform for industrial purposes", Applied Energy Elsevier Limited, Vol. 164, pp. 607-619, February 2016.
- [4] Anitha.k ,prathik, "Smart Energy Meter surveillance Using IoT" ,Institute of Electrical and Electronics Engineers(IEEE), 2019.
- [5] Devadhanishini, et.al" "Smart Power Monitoring Using IoT"5th International Conference on Advanced Computing & Communication Systems (ICACCS) 2019.
- [6] Mohammad Hossein Yaghmaee Design and Implementation of an Internet of Things Based Smart Energy Metering" 6th IEEE International Conference on Smart Energy Grid Engineering 2018.
- [7] Himanshu kpatel "arduino based smart energy meter" 2nd Int'l Conf. on Electrical Engineering Technology (ICEEICT) 2018.
- [8] B. S. Koay, S. S. Cheah, Y. H. Sng, P. H. Chong, P. Shum, Y. C. Tong, X. Y. Wang, Y. X. Zuo and H. W. Kuek, "Design and implementation of Bluetooth energy meter", IEEE Proceedings of the 4th International Joint Conference of the ICICS, vol. 3, pp. 1474-1477, Dec,2003.
- [9] H. Li, S. Gong, L. Lai, R. C. Qiu, D.Yang, "Efficient and Secure Wireless Communication for Advance Metering Infrastructure in Smart Grids," IEEE Transactions on Smart Grid, Vol.3, No. 3, September 2011, pp.1540.
- [10] L.C.Saika, H. Das, N.B Dev Choudhry, T.Malakar, "GPRS enabled smart energy meter and automation of home appliances", IEEE Annual India Conference, pp. 1-5, Bangalore, December 2016.
- [11] Maity, "Intelligent Online Measurement and Management of Energy Meter Data through Advanced Wireless Network," International Conference on Devices and Communications (ICDECOM), pp.1-4, Mesra, 25 Feb. 2011.
- [12] M. A. Alahmad, P. G. Wheeler, A. Schwer, J. Eiden, and A. Brumbaugh, "A comparative study of three feedback devices for residential real-time energy monitoring," IEEE Trans. Industrial Electronics, vol. 59, pp. 2002-2013, Apr. 2012.

- [13] N. Gupta, D. Shukla "Design of Embedded based automated meter reading system for real time", IEEE Student's Conference on Electrical, Electronics and Computer Science, pp.1-6, Bhopal, July 2016.
- [14] S. Kim, E.Y.Kwon, M.Kim, J.H.Cheon, S.Ho Ju, "A Secure Smart Metering protocol over Power Line Communication", IEEE Transactions on Power Delivery, Vol. 26, No. 4, October 2011, pp. 2370.
- [15] M. Popa, "Data Collecting from Smart Meters in an Advanced Metering Infrastructure", IEEE 15th International Conference on Intelligent Engineering Systems (INES), pp. 137-142, Slovakia, 23 June 2011.
- [16] A. Handoko, M. Y. Nayan, M. Awan "Hybrid Automatic Meter Reading System", International Journal of Advanced Research in Computer Science and Software Engineering, Volume 2, No. 7, pp.361-365, Malaysia, July 2012.
- [17] L.C.Saika, H. Das, N.B Dev Choudhry, T.Malakar, "GPRS enabled smart energy meter and automation of home appliances", IEEE Annual India Conference, pp. 1-5, Bangalore, December 2016.
- [18] H. Li, S. Gong, L. Lai, R. C. Qiu, D.Yang, "Efficient and Secure Wireless Communication for Advance Metering Infrastructure in Smart Grids," IEEE Transactions on Smart Grid, Vol.3, No. 3, September 2011, pp.1540. 1
- [19] S.Wang, L.Cui, J.Que, D.H.Choi, X.Jiang "A Randomized Response Model for Privacy Preserving Smart Metering," IEEE Transactions on Smart Grid, Vol.3, No. 3, September 2012, pp.1317.
- [20] F.R. Pazheri, N.H. Malik, A.A. Al-Arainy, EA Al-Ammar, A.Imthias , and O.K. Safoora, " Smart Grid Can Make Saudi Arabia Megawatt Exporter," Proceeding of Asia-Pacific Power and Energy Engineering Conference (APPEEC 20 I I), Wuhan, China, March 2011.
- [21] H.G.R. Tan, C.H.R. Lee, V.H. Mok "Automatic power meter reading system using GSM network," Power Engineering Conference, 2007. IPEC 2007. international, pp.465-469, 3-6 Dec. 2007
- [22] Shang-Wen Luan, Jen-Hao Teng, Shun-Yu Chan, Lain-Chyr Hwang, "Development of a smart power meter for AMI based on ZigBee communication," Power Electronics and Drive Systems, 2009. PEDS 2009. international Conference, pp.661-665, 2-5 Nov. 2009
- [23] Si Chen, Zengwang Yang , "A low cost single phase PLC watt-hour meter based on SoC," Consumer Electronics, Communications and Networks (CECNet), 2012 2nd International Conference, pp.1523-1526, 21-23 April 2012
- [24] Li Li, Xiaoguang Hu; Weicun Zhang, "Design of an ARM-based power meter having WIFT wireless communication module,"Industrial Electronics and Applications, 2009. iCiEA 2009. 4th IEEE Conference pp.403-407, 25-27 May 2009
- [25] B. Massimo "Getting Started with Arduino" \,1 edition, O'REILLY, 2009.
- [26] S. Depuru, W. Lingfeng, V. Devabhaktuni and N. Gudi "Smart meters for power grid Challenges, issues, advantages and status" in Proc. Power Systems Conjerence and Exposition (PSCE), pp.i-7, 20-23 March 2011.
- [27] J. Hurwitz and K. Wing-Hung"ES6: Technologies for smart grid and smart meter," Solid-State Circuits Conference Digest oj Technical Papers (iSSCC), iEEE international, pp.533, 20-24 February 2011.

BIOGRAPHIES



Degala Saranya
Student
VVIT



Kalavakolanu Lakshmi Sarvani
Student
VVIT



Degala Jwalitha
Student
GECG



Indla Sneha Latha
Student
GECG