

FRP Laminated Composite Plate with Central Circular Hole: Structural and Buckling Analysis by FE Method

Kapil Raje¹, Ankur Saxena², Laxmi Jonwar³

¹ Lecturer, Department of Mechanical Engineering, Government polytechnic college sironj vidisha, M.P. 464228 India

² Lecturer, Department of Electrical Engineering, Government polytechnic college sironj vidisha, M.P. 464228 India

³ Research scholar, Department of Computer science & Engineering, NITM Gwalior, M.P. 474006 India

Abstract - The study used finite element analysis (FEA) to Analyze the structural characteristics of thin FRP rectangular composite plates with center holes that were being compressed. FEA was used because of its precision in analyzing complicated geometries and material properties. Under F-F boundary circumstances, the analysis took into account a number of characteristics, including dimension ratio (L/W), stacking structure, and various circle sizes. The results showed that plate deformation and critical load both increased with increasing L/W ratio, with the largest critical load occurring at an L/W ratio of 4. With the exception of mode 2, which exhibited a modest increase in deformation, critical analysis using ANSYS' Eigen value critical tool indicated that the deformation stayed roughly constant with shifting dimension ratios. As the diameter of the circular hole rose, the Critical load gradually Reduced. For various stacking sequences, the Critical load was practically constant for the first and second modes but changed for the third and fourth modes, first decreasing and then increasing. The load behavior of the fifth mode showed a decreasing-then-increasing trend, but the sixth mode displayed more ambiguity with a zigzag pattern. These findings are helpful in the design and study of such structures because they shed light on how composite plates behave under compression loads.

Key Words: Crippling load factor, FEA, FEM, FRP, Round Hole

1. INTRODUCTION

The fundamental objective of laminated composite materials is to combine mechanical properties including stability, ease of handling, low manufacturing costs, high strength/stiffness for lower weight, and improved structure aesthetics. To create ports for mechanical or electrical systems, in order to reduce the weight of the composite materials overall, to join parts inside the building, to act as doors and windows, and other purposes, several sorts of holes are cut into the composite laminated plates. Due to increased stress concentration, high inter laminar stresses, delamination caused by free edges, and a variety of in plane loading circumstances, these cut-outs in laminated constructions lead to collapse. Testing the component under various loading circumstances before it is used can help to reduce this failure.

The several types of structural failure include creep, fatigue, alternative & excessive stresses, bending, and Buckling. The most severe and catastrophic failure that affects composite structures is critical. It is based on the material's stiffness rather than its strength. When structures are subjected to significant axial compressive loads, buckling results in failure. The Critical load is the lowest compressive load that is greater than the maximum load value. Buckling can potentially cause a collapse due to the elastic instability it causes. Investigating the critical behaviour of structures with various characteristics is therefore crucial for the design's dependability and safety under certain operating situations. It is also vital to know the maximum load that the structure can support.

There are many techniques to lessen or eliminate Buckling, such as altering the aspect ratio of plates, raising the buckling load by altering the fibre orientation, or adjusting the applied load. In contrast to numerical methods, which take more time and require equation solving, scientists and engineers have adopted experimental methods to estimate Critical bucking loads since they are less laborious and time-saving. For their experiments, they used an INSTRON tensile testing machine, which is cumbersome, rigid, and only applies uniaxial loads. This work develops a biaxial tensile testing system that can provide loads that are more closely related to actual working conditions.

The Advantages of Composite Materials Composite materials have a relatively high strength to weight ratio when compared to their separate fibers/particles and matrix. Composite materials are very rigid in compared to their individual components. In comparison to conventional materials, vibration amplitude has decreased due to the superior dampening properties of composite materials. Increased wear resistance increases the composite construction's lifespan. For instance, the electrical conductivity of composite materials can be increased by introducing graphite fibers. Composite materials can have a flexible

design. Numerous composite materials benefit from having poor thermal conductivity in application. Composites usually outlast other materials and require less ongoing care than other materials.

LIST OF ABBREVIATIONS:

1	F-F	Fixed-fixed boundary condition
2	FEA	Finite Element Approach
3	FEM	Finite Element method
4	FRP	Fiber reinforced plate
5	CLF	Crippling load factor
6	L	Length
7	W	Breadth
8	K	(L/W) Dimension ratio or size ratio

2. LITERATURE REVIEW

Dona Chatterjee et. al.[1]In this study, the first ply failure analysis of laminated composite clamped skew plates subjected to uniformly distributed transverse static load is discussed. It is described and thoroughly investigated how changing the skew angle affects the first ply failure loads of laminated composite skew plates. Nikhil Aditya et.al.[2]used ANSYS to perform a linear crippling study on a plate to determine the load multiplier for a plate with a V-shaped notch on one edge. They noticed that the load multiplier decreases as the notch angle increases. Additionally, plate Buckling behaviour affects boundary conditions. Juan Carlos Pina et.al.[3]This study examines the Cross-Laminated Timber (CLT)'s ability to buckle under compressive pressures. An optimization-based parameter identification technique is used to calibrate the micromechanical properties of wood in order to enhance the numerical predictions. Dilu Riswana et.al.[4]this studies Cutout location, fiber orientation angle, length to thickness ratio, boundary condition, and Young's modulus ratio are the variables taken into account. The laminated plates under analysis are made of composite materials with carbon fiber reinforcement. Comparing plates with and without circular cutouts, they found that laminated composite plates exhibit less Crippling load. Monica S Swamy et.al.[5]The Buckling behavior of homogeneous and heterogeneous plate elements with and without cracks was examined using numerical analysis, finite element software ANSYS, and Timoshenko's approach, as summarized in this article. Additionally, the impact of aspect ratio on the Buckling behavior with variable plate thickness under various boundary circumstances was also looked at. Shahed Jafarpour Hamedani et. al.[6]Using both traditional and super finite element techniques, this research analyzes the Buckling of stiffened plates. Investigation is done into how varied boundary conditions and biaxial load combinations affect the Buckling characteristics of stiffened panels.K.Mallikarjuna Reddy et.al.[7]The Buckling behavior of laminated composite plates under uniaxial and biaxial compression strain is investigated in this research using commercially available ANSYS software. For three different materials, various finite element calculations have been conducted to investigate the impact of side-to-thickness ratios, aspect ratios, modulus ratios, ply orientation, and boundary conditions on non-dimensionalized Criticalcripling loads.Gowri Sankar Kakani et.al.[8]The current study uses a finite element method based on the Classical Laminate Theory (CLT) to predict the geometric nonlinear behavior of a thin, five-layered, symmetric cross-ply Fiber Reinforced Plastic (FRP) skew laminated composite plate with a circular cutout in the geometric center of the plate. Buket okutan baba[9]The effect of boundary conditions on the Buckling load for rectangular plates with different cutout shapes, length/thickness ratios, and ply orientations is investigated in this work. Considered are boundary conditions that include clamped, pinned, and their combinations.Dr. Hani Aziz Ameen[10]An experimental research was conducted on numerous specimens of composite materials made of E-glass fiber reinforced polyester plastic materials with various numbers of layers using the ANSYS program. The impact of cutoff dictated whether Buckling increased or decreased.

3. Objective

The intended objective of the current study is to analyse using finite element method techniques, to Conduct structural analysis and Buckling functionality of thin FRP rectangular composite plates with circular holes that have been subjected to forces of compression.FEA analysis is used to calculate the eigen value Critical load for a variety of variables that include aspect ratio (L/W), stacking order, and various circle sizes under F-F boundary conditions.

4. Geometric modelling and Methodology

4.1 Geometry

A composite plate model with dimensions of 200 mm in length, 100 mm in breadth, and a 30 mm circular hole in the middle was used in this experiment. To achieve the desired Dimension ratio of 2,2.5,3,3.5,4, the width (W) of the composite plate is set at 100mm and the length (L) is changed to increase by 50mm at every stage here. In the current study, the fixed-fixed(F-F) boundary condition was adopted for analysis.

Using the ANSYS ACP Pre module in ANSYS SOFTWARE, a total of 4 layers with a 1 mm thickness each are produced. Modular geometry is created by using the ANSYS pre design software. The geometry is translated to static structural analysis. After developing model, the FRP composite plate's CRITICAL tendency is then determined by using an eigen value Buckling module.

Table -1 Geometry dimensions of Composite plate

LENGTH(L)	WIDTH(W)	THICKNESS(t)	DIAMETER OF HOLE(d)
200mm	100mm	1 mm	30mm

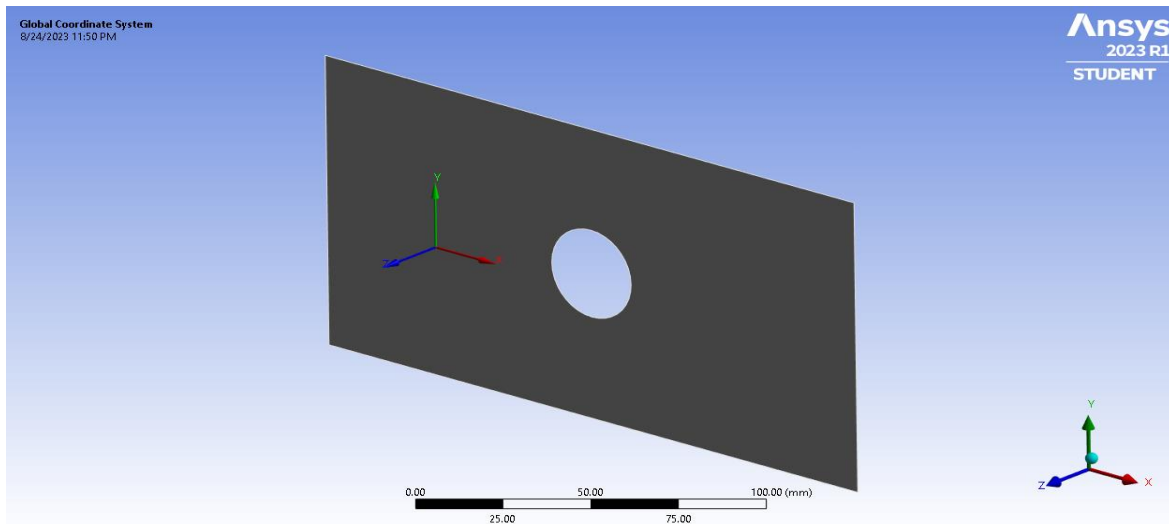

Fig-1 CAD model of composite plate with round hole

4.2 Definition of Material Property

Table -2 composite material's linear orthotropic properties of carbon fibre

ElasticModulus(gpa)			Poission Ratio			Modulus of Rigidity (gpa)		
E12	E23	E13	μ_{12}	μ_{23}	μ_{13}	G12	G23	G13
230	23	23	0.2	0.4	0.2	9	8.214	9

4.3 Meshing and Element definition

For composite plate, a material definition is provided. Carbon composite has been defined as a material. According to table 2 above, the substance is of the orthotropic kind. Hexahedral and quadrilateral pieces make up the mesh of the plate. Model of the composite plate mesh is shown in Figure 5.

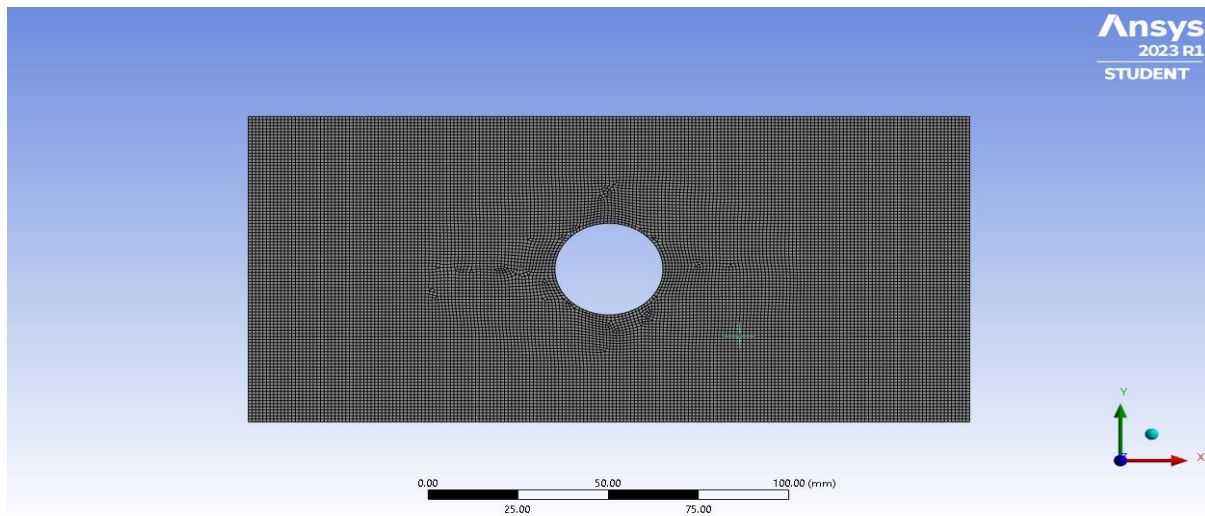

Fig-2 Meshed model of FRP plate

4.4 Stack up definition

A multitude of laminates make up the composite material. There are thickness and orientation angle specifications for each laminate as well as the several design pairings, including L/W.

There Are a total of four separate layers that have been described, each of which has a predetermined thickness value of 1mm and a specific orientation angle. These layers have been Meshes with the necessary rosette and orientated element sets. (0-90-90-0). The structural orientation of various laminates in their various forms is shown in Figure 4.

ACP Model
08/24/23 23:59
Thickness
Element-Wise
Unit: mm
Misc: 4
Misc: 4

Ansys
2023 R1
TEACHING



Fig-3 ACP model of the plate Different laminas with orientation with total thickness of 4mm

4.5 Loads and Boundary Conditions

The critical load is calculated by applying structural loads to a plate. On the top and bottom crucial points of the composite plate, an initial 1000N load is applied. The composite plate's left and right lines are applied with a fixed support. As forces and boundaries have been placed to the structure, a simulation is run. A generalized stiffness vector is produced and put together during the procedure.

4.6 Solution

Selecting the "solve" icon causes the simulation to run after the loads and boundary conditions have been entered. The rigidity matrix for the element is created during the solution procedure, and nodal outcomes are used to interpolate the results over the whole length of the element's edge.

5. Result and Discussion

In the current study, carbon composite material will be used to conduct structural Analysis for L/W ratio of 2,2.5,3,3.5,4,to determine shear stress, principal stress and elastic stress and Buckling analyses in order to determine the Critical load characteristics of composite plates for various size ratios, stacking orders, and circle sizes F-F border conditions.

5.1 Structural analysis

5.1.1 L/W ratio of 2

On a rectangular plate made of carbon composite material with an L/W ratio of 2, a structural analysis was done. Through the use of FEA on a rectangular plate, the shear stress plot in the xy direction is generated. The corners of the plate appear to have the highest xy shear stress, which is measured there to be 2.87MPa in magnitude.

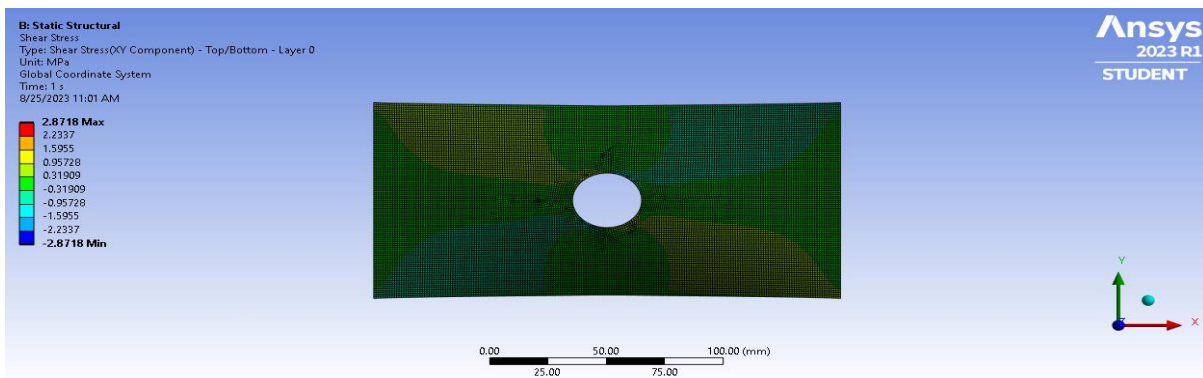

Fig-4: xy shear stress for l/w ratio of 2 value and Carbon CompositeMaterial

For the plate made of composite material, the principal stress magnitude is determined. The maximum principal stress is observed close to the border when it is subject to fixed support boundary conditions. A maximum primary stress of 22.3MPa was obtained from the analysis.

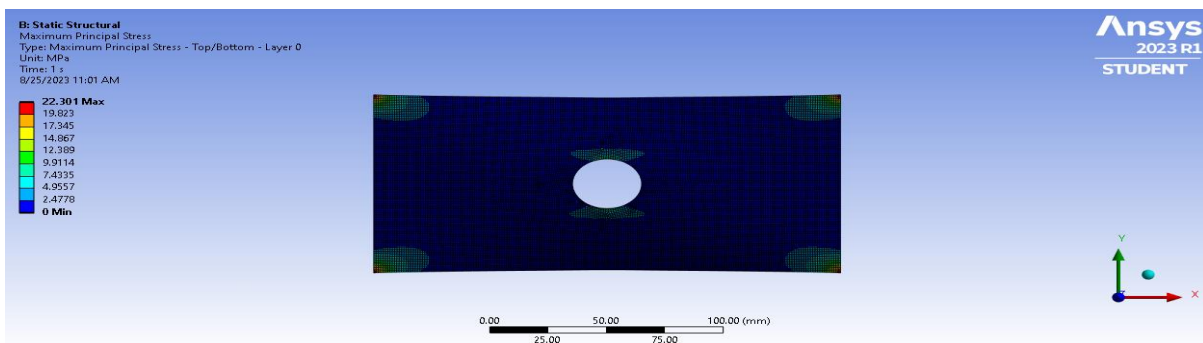

Fig-5: Max. principal stress for L/W ratio of 2 value and Carbon Composite Material

For a carbon composite plate with an L/W ratio of 2, the elastic strain of shear in the xy direction has been calculated. This plate is shown in Figure 9. A maximum xy shear strain of.00014453 mm/mm was determined by the study.

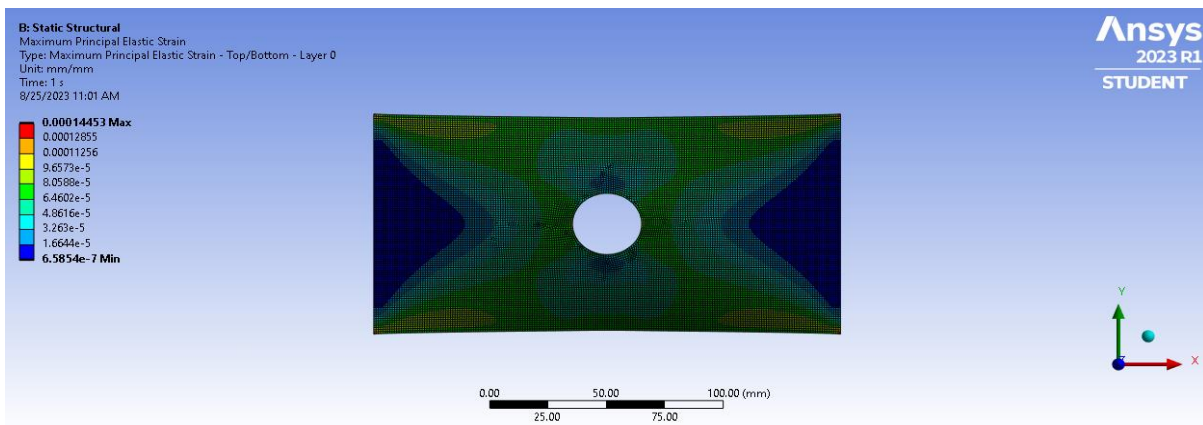

Fig-6:Max. principal elastic strain for L/W ratio of 2 value and Carbon Composite Material

5.1.2 L/W ratio of 2.5

On a rectangular plate made of carbon composite material with an L/W ratio of 2.5, a structural analysis was done. Through the use of FEA on a rectangular plate, the shear stress plot in the xy direction is generated. The corners of the plate appear to have the highest xy shear stress, which is measured there to be 2.2967 MPa in magnitude.

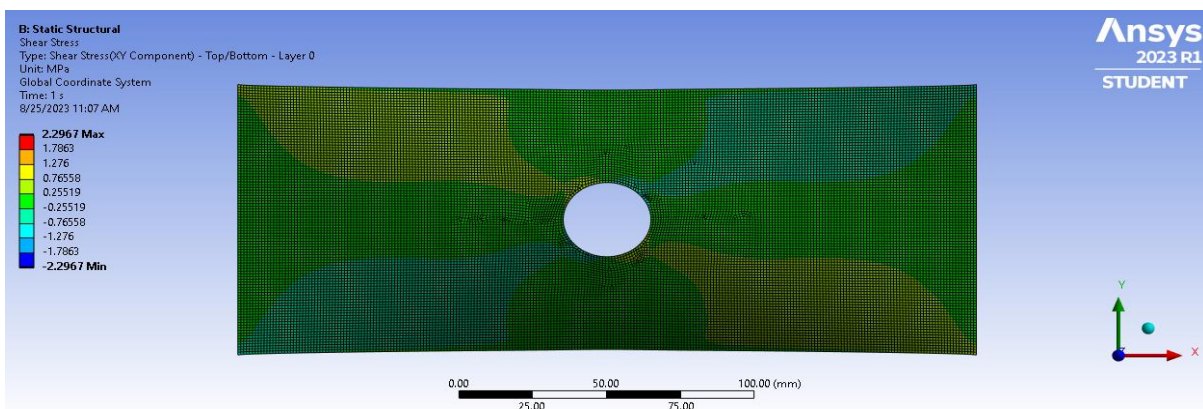

Fig-7: xy shear stress for L/W of 2.5 value and Carbon Composite Material

For the plate made of composite material, the principal stress magnitude is determined. The maximum principal stress is observed close to the border when it is subject to fixed support boundary conditions. A maximum primary stress of 17.435MPa was obtained from the analysis.

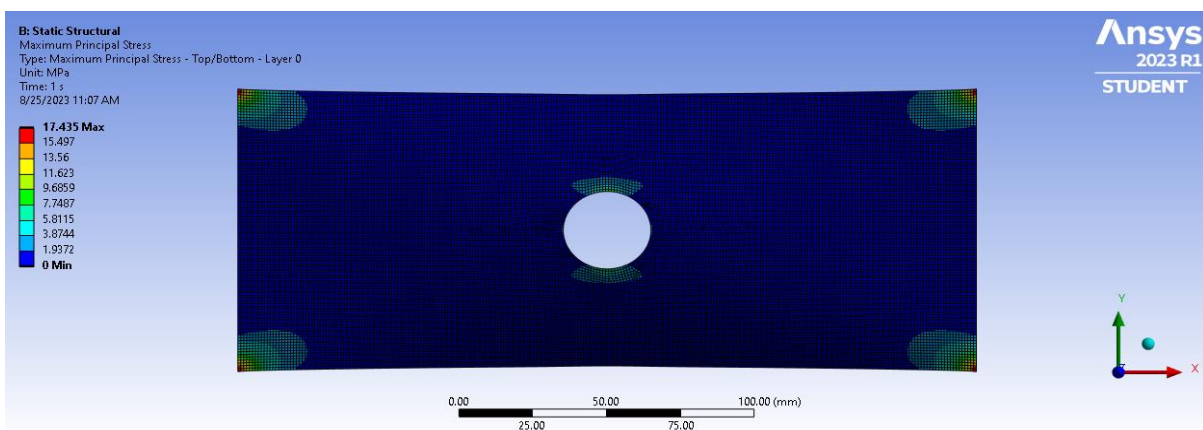

Fig-8: Max. principal stress for L/W ratio of 2.5 value and Carbon Composite Material

For a carbon composite plate with an L/W ratio of 2.5, the elastic strain of shear in the xy direction has been calculated. This plate is shown in Figure 12. A maximum xy shear strain of 0.00011436 mm/mm was determined by the study.

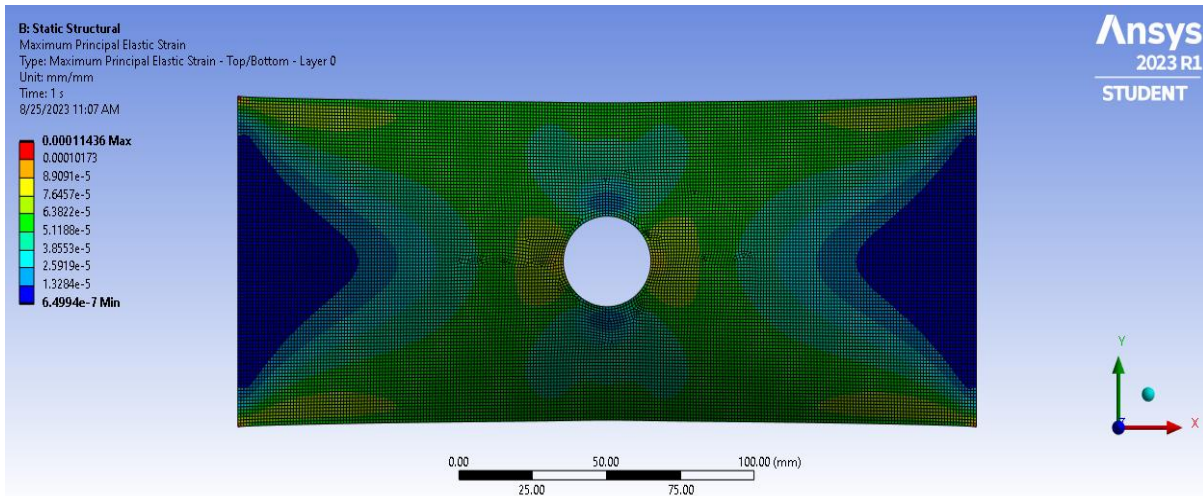

Fig-9: Max. principal elastic strain for L/W ratio of 2.5 value and Carbon Composite Material

5.1.3 L/W ratio of 3

On a rectangular plate made of carbon composite material with an L/W ratio of 3, a structural analysis was done. Through the use of FEA on a rectangular plate, the shear stress plot in the xy direction is generated. The corners of the plate appear to have the highest xy shear stress, which is measured there to be 1.9138MPa in magnitude.

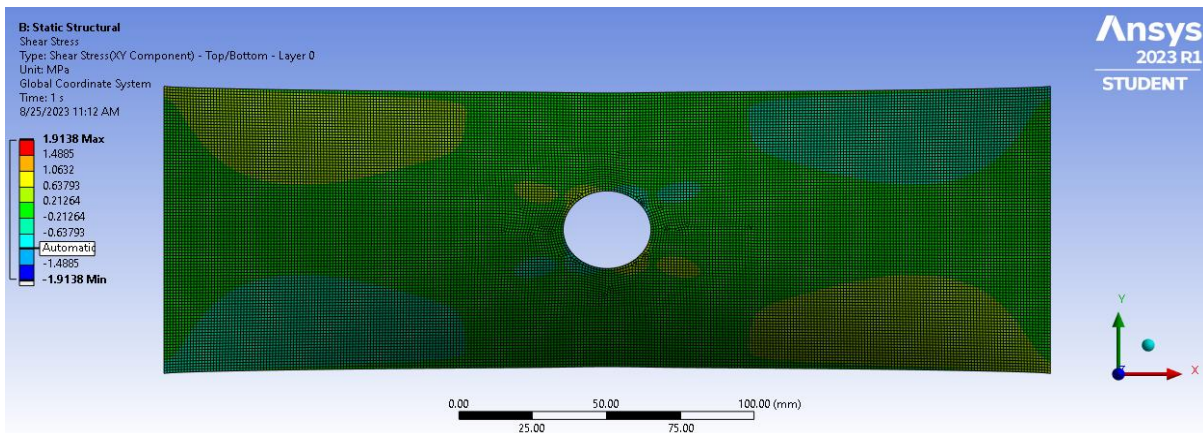

Fig-10: xy shear stress for l/w of 3 value and Carbon Composite Material

For the plate made of composite material, the principal stress magnitude is determined. The maximum principal stress is observed close to the border when it is subject to fixed support boundary conditions. A maximum primary stress of 14.341MPa was obtained from the analysis.

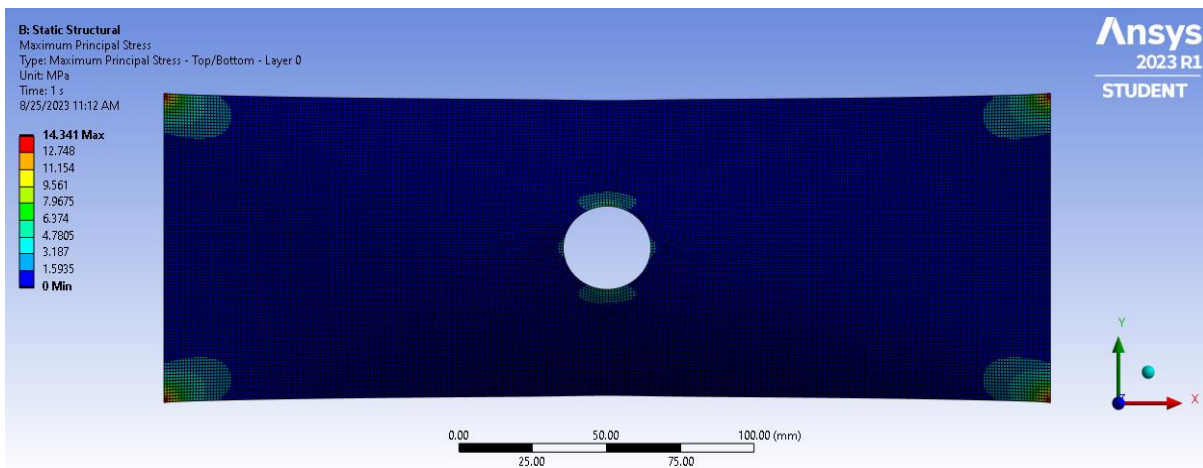

Fig-11: Max. principal stress for L/W ratio of 3 value and Carbon Composite Material

For a carbon composite plate with an L/W ratio of 3, the elastic strain of shear in the xy direction has been calculated. This plate is shown in Figure 15. A maximum xy shear strain of 0.0000947 mm/mm was determined by the study.

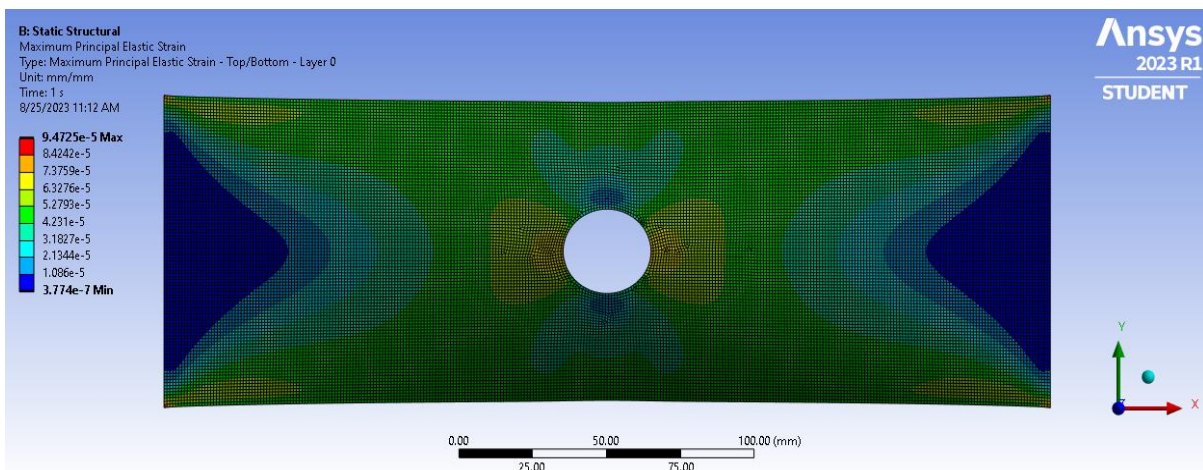

Fig-12: principal elastic strain for L/W ratio of 3 value and Carbon Composite Material

5.1.4 L/W ratio of 3.5

On a rectangular plate made of carbon composite material with an L/W ratio of 3.5, a structural analysis was done. Through the use of FEA on a rectangular plate, the shear stress plot in the xy direction is generated. The corners of the plate appear to have the highest xy shear stress, which is measured there to be 1.6403MPa in magnitude.

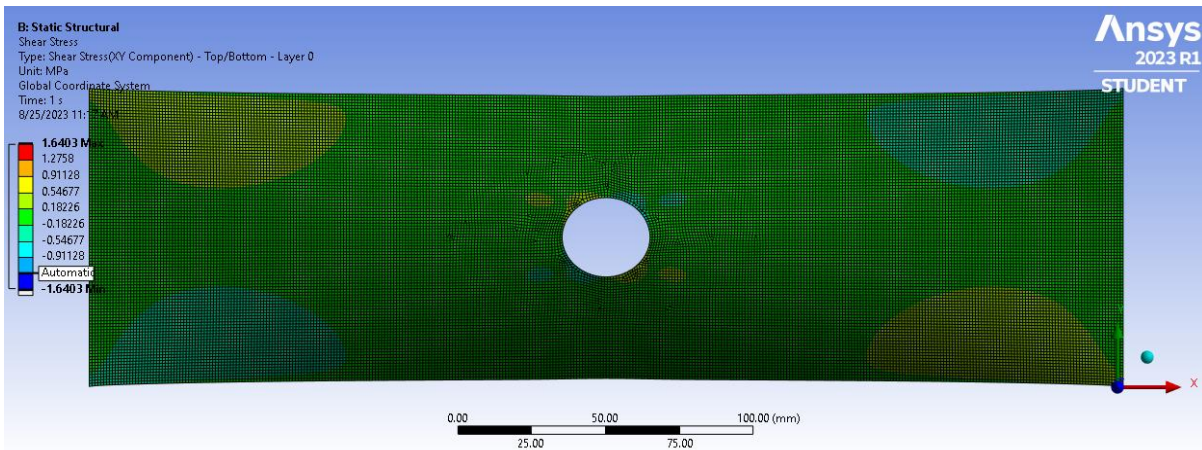

Fig-13: xy shear stress for L/W ratio of 3.5 and Carbon Composite Material

For the plate made of composite material, the principal stress magnitude is determined. The maximum principal stress is observed close to the border when it is subject to fixed support boundary conditions. A maximum primary stress of 12.247MPa was obtained from the analysis.

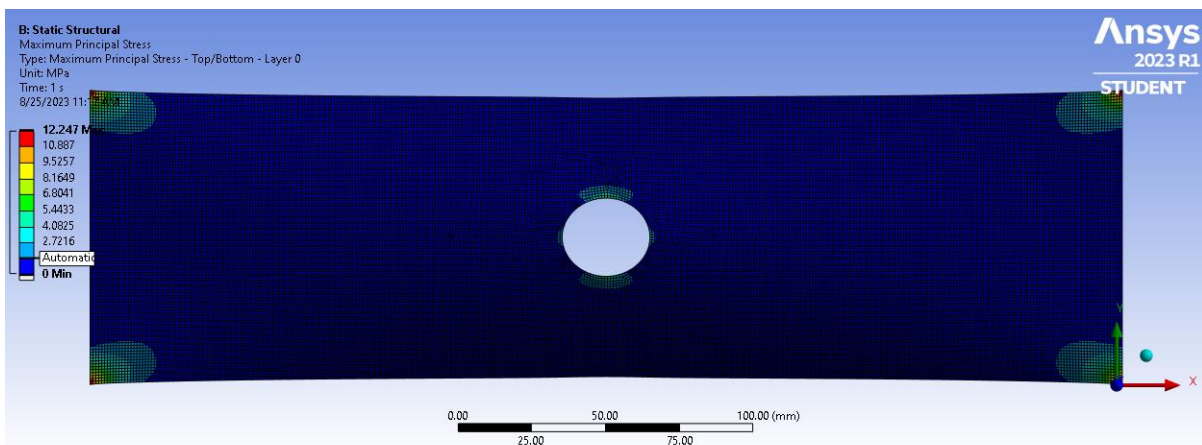

Fig-14: Max. principal stress for L/W ratio of 3.5 value and Carbon Composite Material

For a carbon composite plate with an L/W ratio of 3.5, the elastic strain of shear in the xy direction has been calculated. This plate is shown in Figure 18. A maximum xy shear strain of 0.0000811 mm/mm was determined by the study.

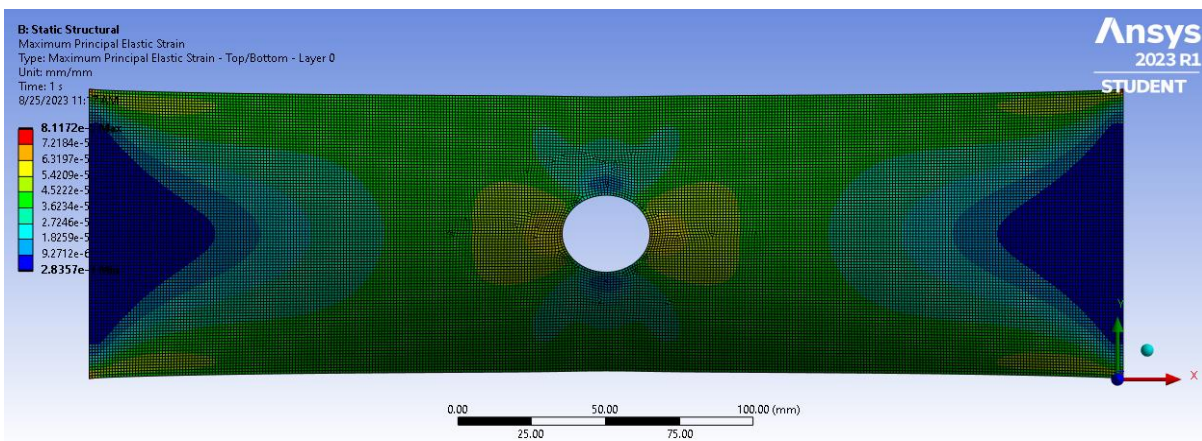

Fig-15: principal elastic strain for L/W ratio of 3.5 value and Carbon Composite Material

5.1.5 L/W ratio of 4

On a rectangular plate made of carbon composite material with an L/W ratio of 2, a structural analysis was done. Through the use of FEA on a rectangular plate, the shear stress plot in the xy direction is generated. The corners of the plate appear to have the highest xy shear stress, which is measured there to be 2.87MPa in magnitude.

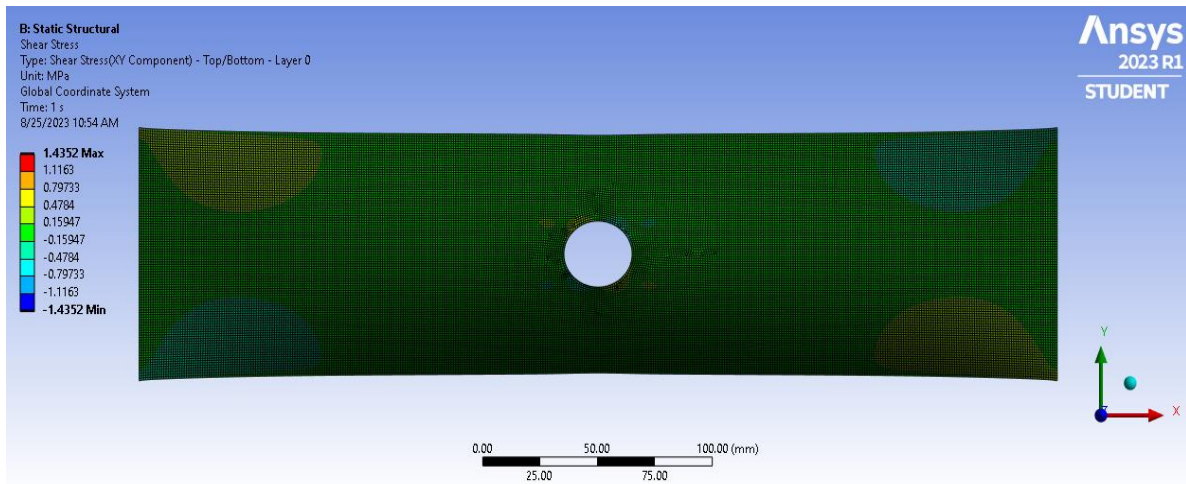

Fig-16: xy shear stress for L/W of 4 value and Carbon Composite Material

For the plate made of composite material, the principal stress magnitude is determined. The maximum principal stress is observed close to the border when it is subject to fixed support boundary conditions. A maximum primary stress of 10.719MPa was obtained from the analysis.

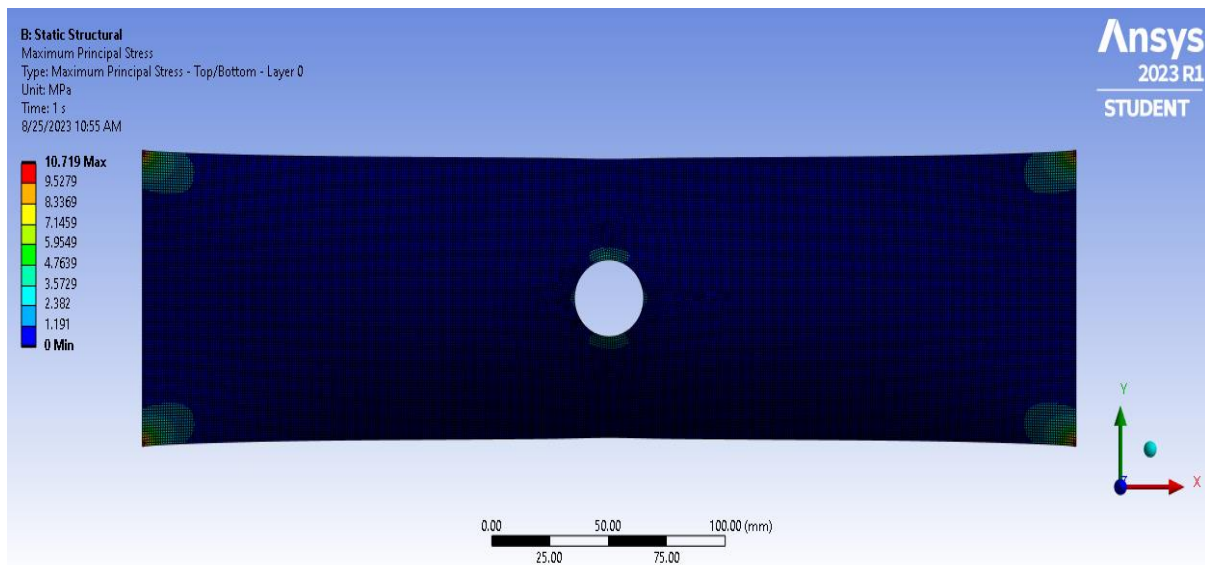

Fig-17: Max. principal stress for L/W ratio of 4 value and Carbon Composite Material

For a carbon composite plate with an L/W ratio of 2, the elastic strain of shear in the xy direction has been calculated. This plate is shown in Figure 21. A maximum xy shear strain of 0.00007099 mm/mm was determined by the study.

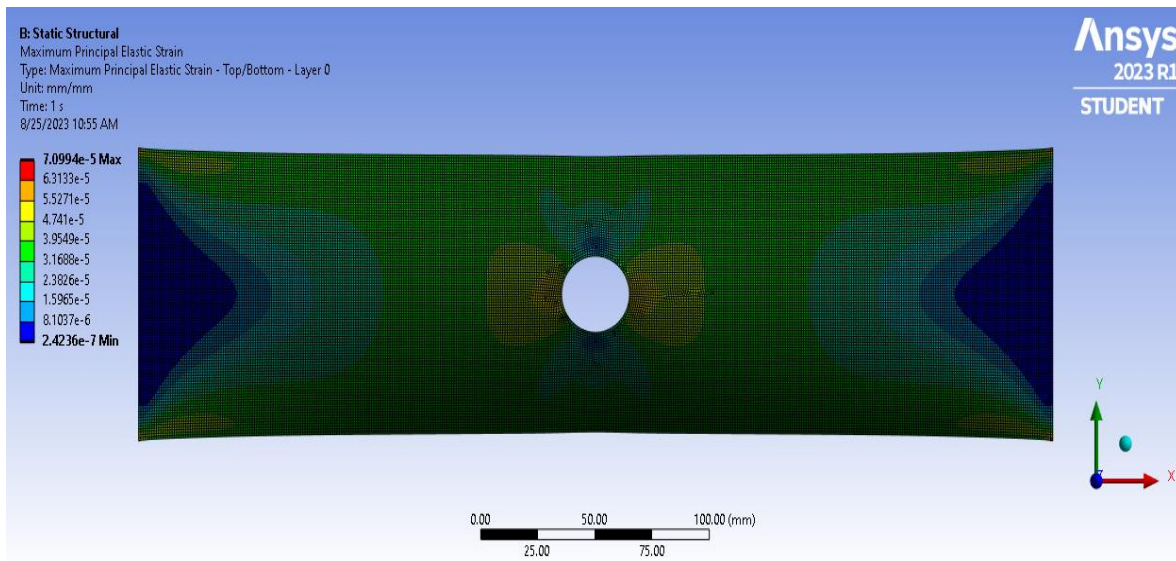

Fig-18: principal elastic strain for L/W ratio of 4 value and Carbon Composite Material

5.1.6 Comparative Research

Comparative studies are conducted between various L/W designs for 2, 2.5, 3, and 4.

Table 5.1: Carbon composite results

Design type	L/W 2	L/W 2.5	L/W 3	L/W 3.5	L/W 4
Shear stress	2.8718	2.2967	1.9138	1.6403	1.4352
Principal stress	22.30	17.435	14.341	12.247	10.719
Elastic strain	0.00014453	0.00011436	0.0000947	0.0000811	0.00007099

According to the comparison plot of shear stress, principle stress, and elastic strain, the shear stress, principal stress, and elastic strain caused on the plate decrease as laminate thickness increases, as shown in the table above. The plate that produces the lowest shear stress, principal stress, and elastic strain has an L/W ratio of 4.

5.2 Buckling Analysis

Any engineering structure like composite plate having circular hole at middle when subjected to compressive load under fixed-fixed boundary condition Buckling is a common phenomenon due to unable to carry maximum load called Critical load

The Buckling analysis is conducted on plate using ANSYS Eigen value Buckling tool for composite material and L/W ratio of 2,2.5,3,3.5,4, layer thickness, stacking sequence, different circle diameter in F-F boundary conditions. For determining crippling load, the FEA analysis is conducted at 1000 N load. The Eigen value Buckling value is determined.

According to figure 22, the deformation reported by FEA analysis of a composite plate with L/W 2 is 1.005mm. The crippling load for a composite plate with L/W of 2 is calculated and is discovered to be 59.32N.

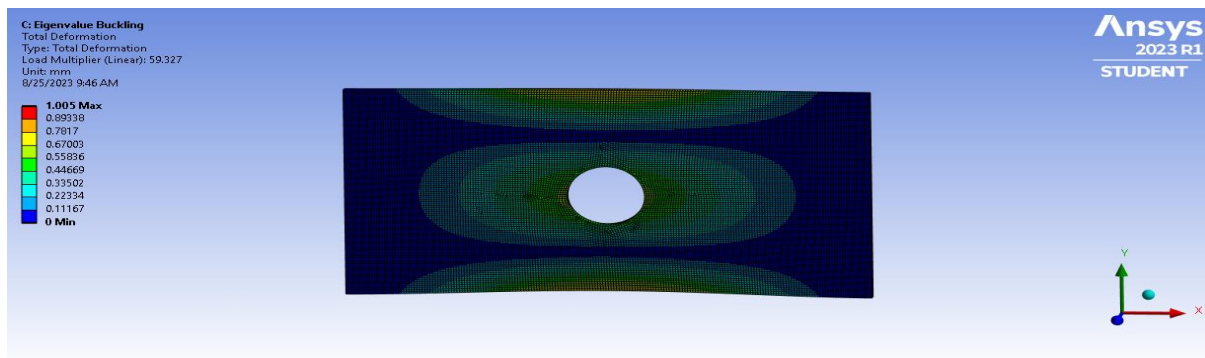

Fig-19: Deformation plot on plate for L/W 2

According to figure 23, the deformation reported by FEA analysis of a composite plate with L/W 2.5 is 1.0009mm. The CRITICAL load for a composite plate with L/W of 2.5 is calculated and is discovered to be 35.991N.

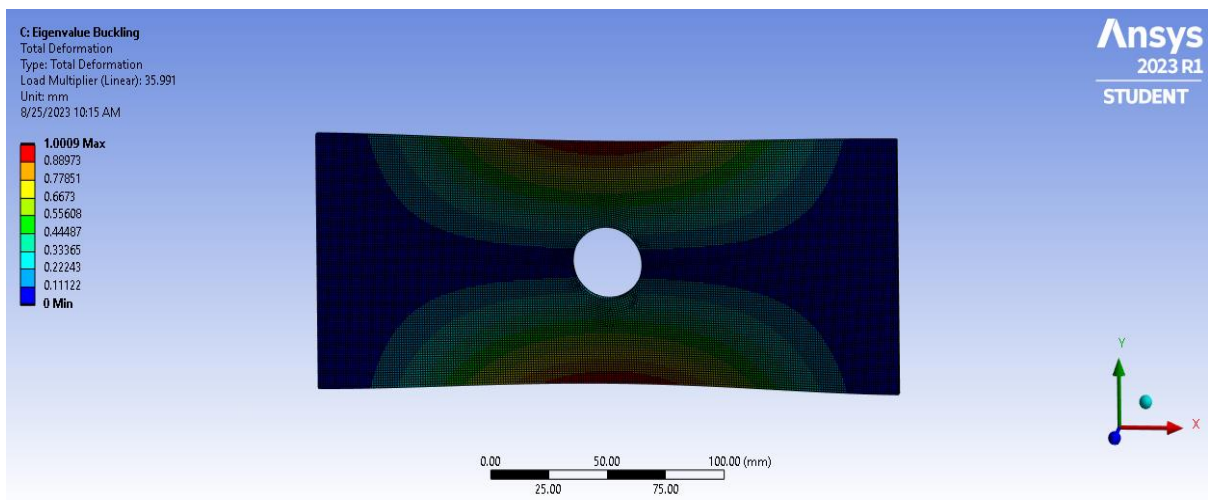

Fig-20: Deformation plot on plate for L/W 2.5

According to figure 24, the deformation reported by FEA analysis of a composite plate with L/W 3 is 1.0009mm. The crippling load for a composite plate with L/W of 2 is calculated and is discovered to be 23.53N.

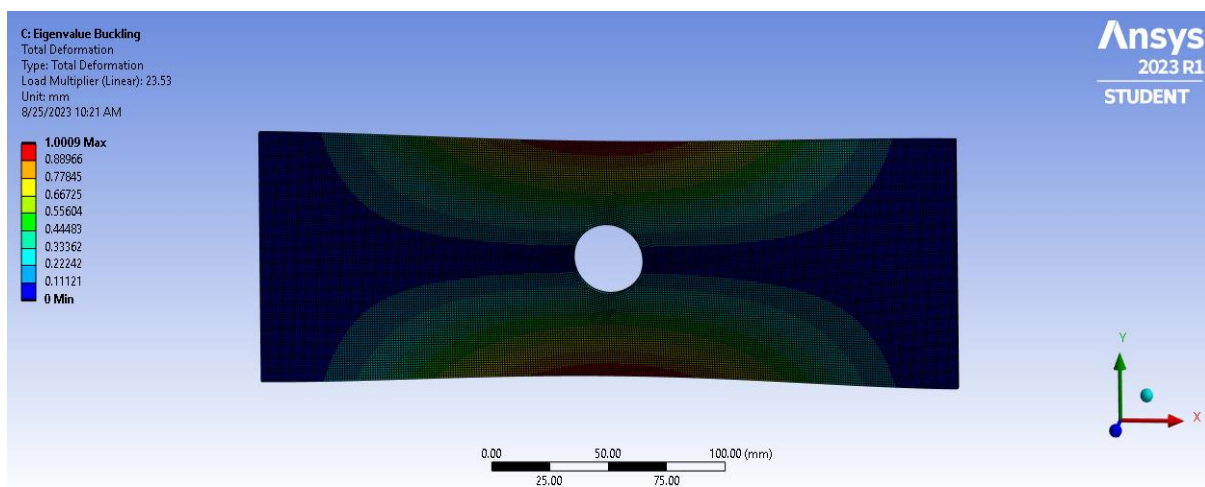

Fig-21: Deformation plot on plate for L/W 3

According to figure 25, the deformation reported by FEA analysis of a composite plate with L/W 4 is 1.0008mm. The Buckling load for a composite plate with L/W of 2 is calculated and is discovered to be 12.513N.

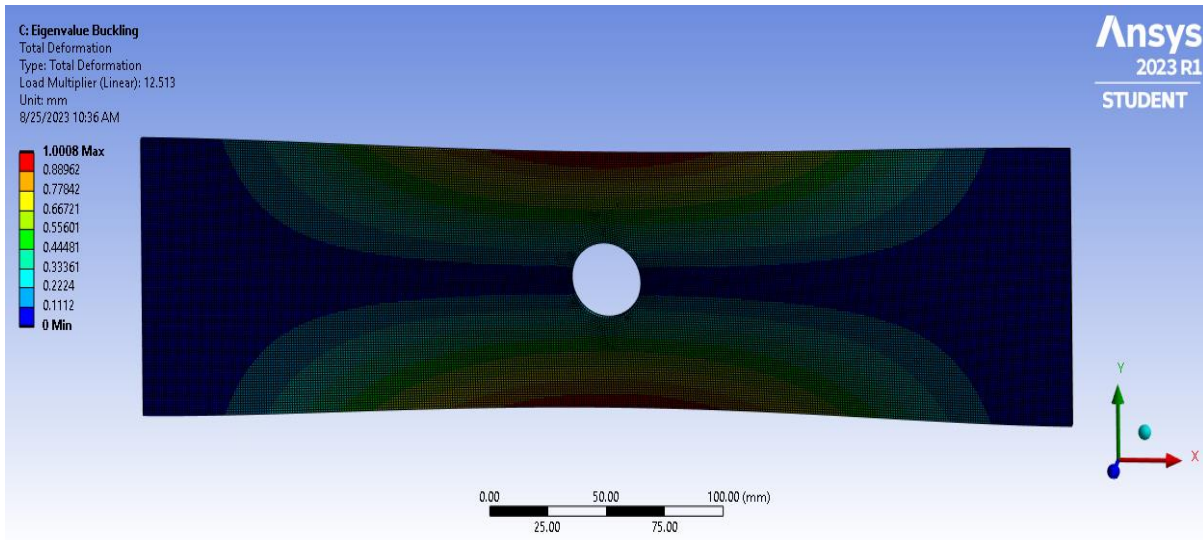

Fig-22: Deformation plot on plate for L/W 4

5.2.4 DEFORMATION VS ASPECT RATIO

With the change in dimension ratio the deformation of plate is approximate constant. for the mode 2 deformation increases little. But for other modes it is constant due to fixing of plate and its rigidity. S shown in graph below.

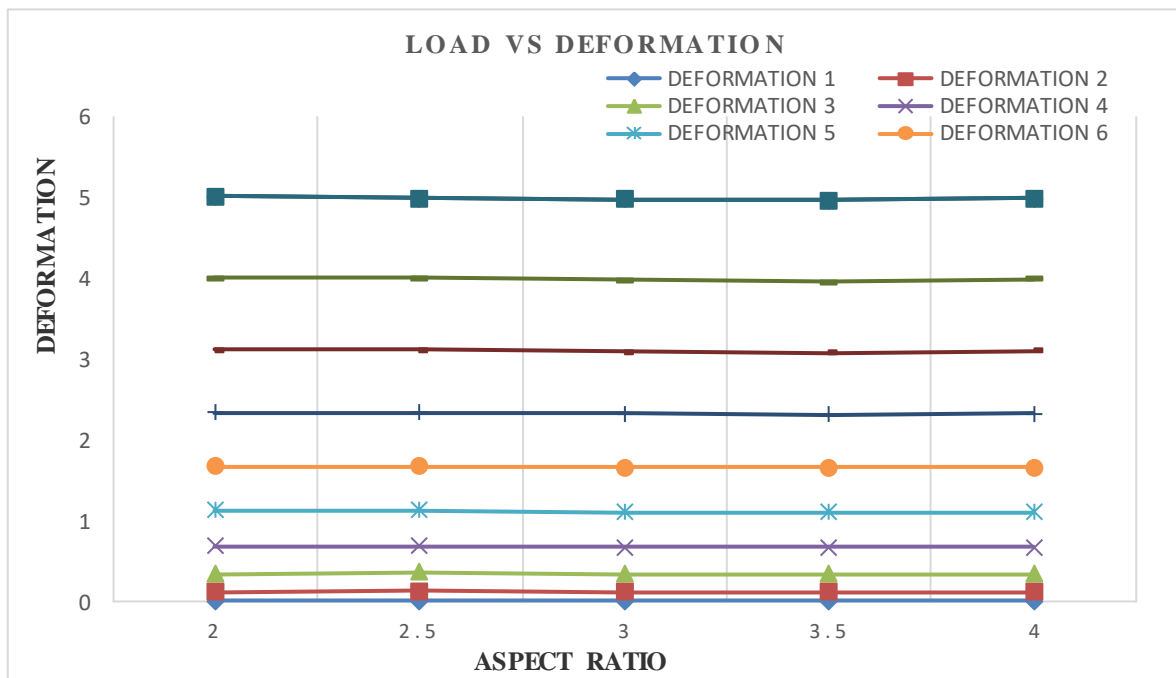

Fig-23: deformation due to different size ratio

5.2.1 Effect of Aspect/Size ratio

Rectangular orthotropic plate with circular hole at middle was investigated using FEM for dimension ratio of 2,2.5,3,3.5, and 4. Width of composite is fixed at 100mm and length is increased by 50mm to make required aspect ratio.

It is evident from graph that with increase in dimension ratio the length of plate increases resulting in reduce in crippling load. Dimension ratio of 2 has the highest Critical load that is maximum load carrying capacity as compared to dimension ratio of 6.

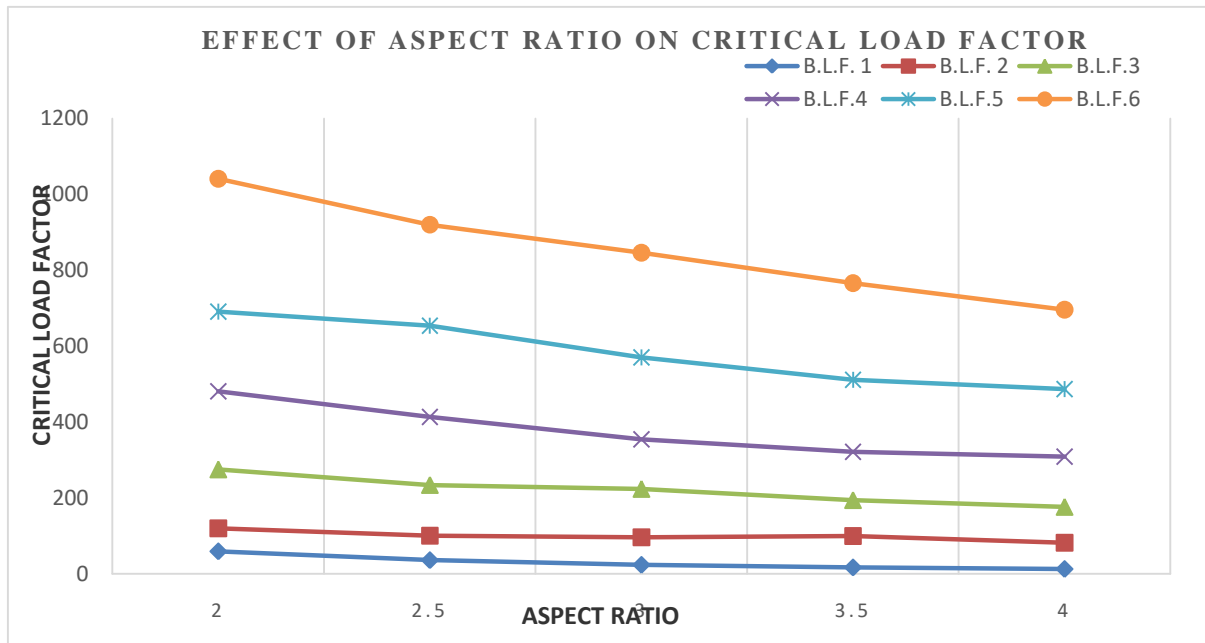

Fig-24 Effect of size/Aspect ratio on the CRITICAL load Under F-F boundary condition

5.2.2 Effect of Hole Diameter:

From the 1st to 6th mode the Critical load decreasing steadily as circular hole diameter increasing. So mode 1 has maximum crippling load as compared to mode 3, mode 3 has more than mode 4 and mode 6 has minimum Critical load as compared to mode 5 due to low stiffness making the plate more unstable.

Figure below shows the behaviour of composite with hole diameter.

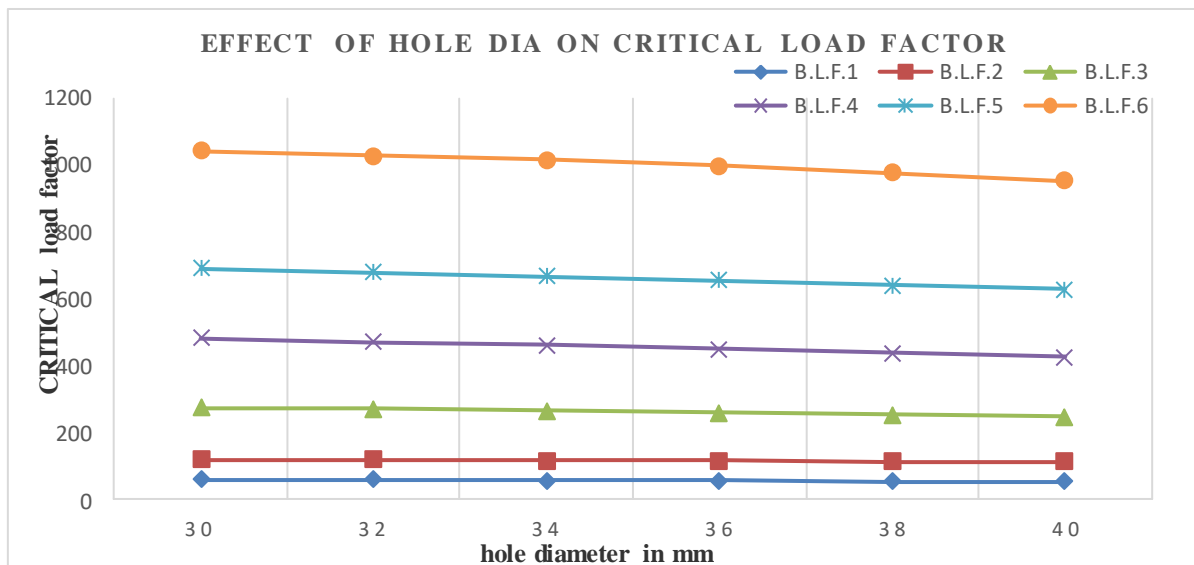

Fig-25 Effect of Hole Diameter on the Critical load Under F-F boundary condition

5.2.5 Influence of Stacking Sequence

4stacking Configuration [0-45-45-0], [45-0-0-42], [0-45-0-45], [45-0-45-0] taken into consideration to how Critical behaviour of composite take place. Stacking configuration is shown below.

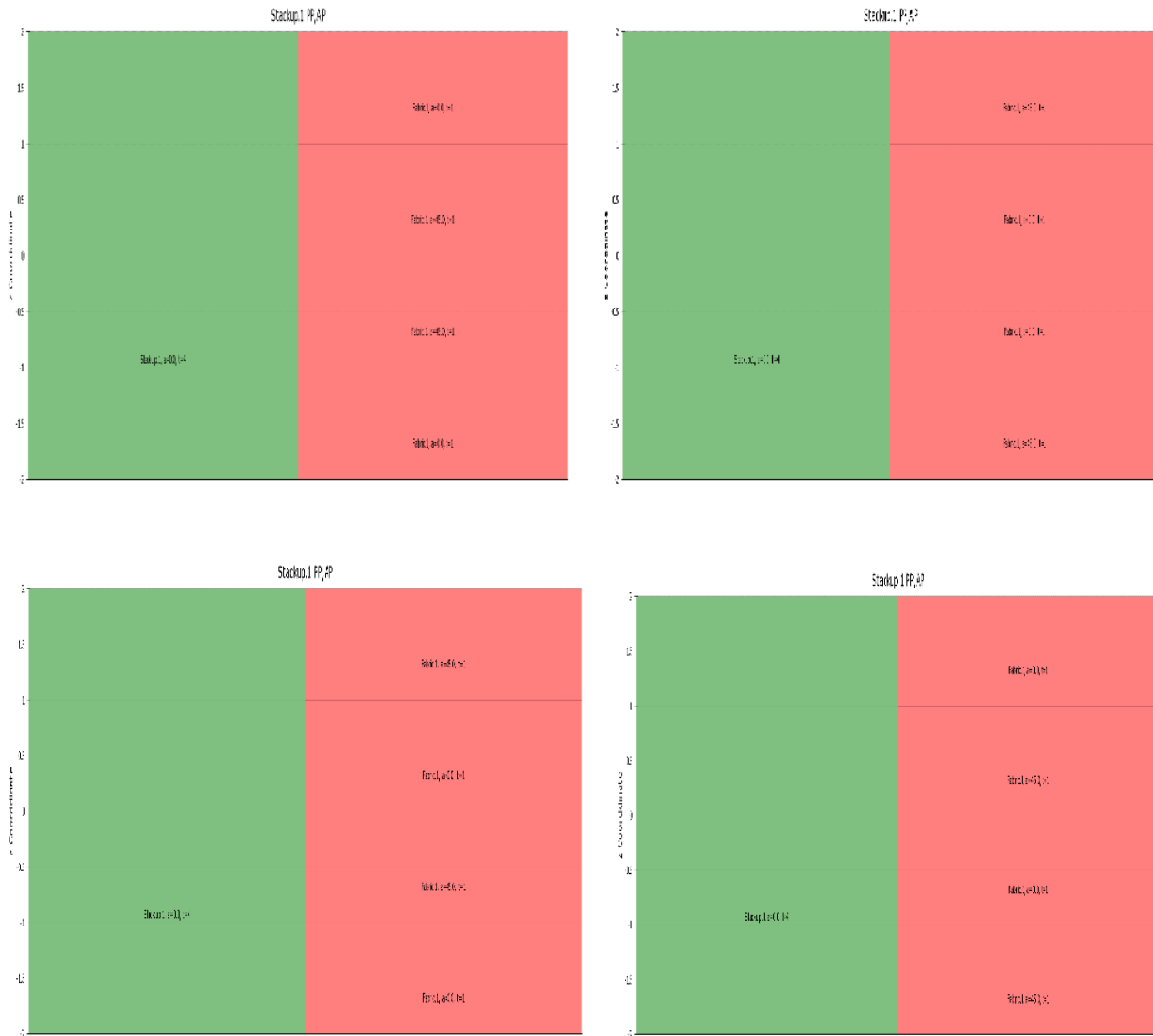

Fig-26 Different Configuration for Different Stacking Sequence

It is clear from the graph that the Critical load is almost remain same for 1st and 2nd mode. for 3rd and 4th mode the Critical load is decreasing and then increasing. For 5th mode the load is decreasing and then increasing at more rate. Mode 6th is more uncertain here the load is decreasing and increasing in zig-zag manner.

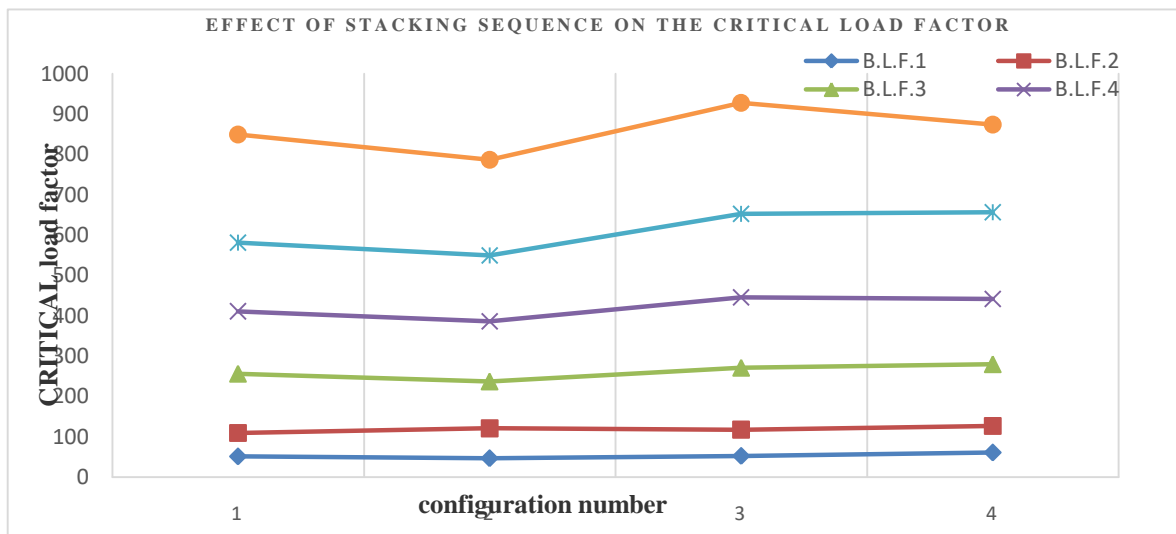

Fig-27 Effect of stacking Arrangement on the Critical load Under F-F boundary condition

6. CONCLUSION

Because it offers accurate and detailed information on how composite structures behave when subjected to different loads, Finite Element Analysis (FEA) is a preferred method for analysing composite plates. Using traditional analytical methods, it is difficult to examine complex geometries and material properties, but FEA makes it practicable for it to do so. The current study's intended target is to examine the structural structural properties of thin FRP rectangle composite plates with holes in the middle that have been subjected to compression stresses utilizing finite element method tactics. Under F-F boundary conditions, FEA analysis uses simulation to figure out the eigenvalue Critical load for a number of aspects, including dimension ratio (L/W), stacking structure, and different circle diameters of various sizes. It was observed that in structural Analysis for L/W ratio of 2,2.5,3,3.5 and 4. The results showed that the plate deformation increased when the L/W ratio was rising. Similar to the principal stress and elastic strain, the crippling load rose as the L/W ratio became bigger, with the greatest crippling load being found at an L/W ratio of 4. The buckling analysis is conducted on plate using ANSYS eigen value buckling tool for composite material and L/W ratio of 2,2.5,3,3.5,4, layer thickness, stacking sequence, different circle diameter in F-F boundary conditions. It was discovered that With the change in dimension ratio the deformation of plate is approximate constant. for the mode 2 deformation increases little. But for other modes it is constant due to fixing of plate and its rigidity. with increase in dimension ratio the length of plate increases resulting in reduce in crippling load. the Critical load decreasing steadily as circular hole diameter increasing. In different stacking sequence the Critical load is almost remain same for 1st and 2nd mode. for 3rd and 4th mode the Critical load is decreasing and then increasing. For 5th mode the load is decreasing and then increasing at more rate. Mode 6th is more uncertain here the load is decreasing and increasing in zig-zag manner.

REFERENCES

- [1] D. Chatterjee, A. Ghosh, and D. Chakravorty, "Nonlinear first ply failure study of laminated composite skew plates," *Mater. Today Proc.*, vol. 45, pp. 4925–4930, 2021, doi: 10.1016/j.matpr.2021.01.370.
- [2] N. Aditya, "Linear CRITICAL behaviour of (30 / - 60) n laminates containing V- shaped edge notch using FEM by Nikhil Aditya," 2021.
- [3] J. C. Pina, E. I. Saavedra Flores, and K. Saavedra, "Numerical study on the elastic CRITICAL of cross-laminated timber walls subject to compression," *Constr. Build. Mater.*, vol. 199, pp. 82–91, 2019, doi: 10.1016/j.conbuildmat.2018.12.013.
- [4] J. Rezaeepazhand and A. M. Darbari, "CRITICAL of composite plates with cutouts," *Compos. Technol.* 2020, pp. 325–330, 2004.
- [5] P. G. Student, C. Engineering, and A. Chunchanagiri, "CRITICAL Analysis of Plate Element Subjected to In Plane Loading Using ANSYS," pp. 3121–3130, 2015, doi: 10.15680/IJIRSET.2015.0405090.

- [6] S. Jafarpour Hamedani and A. Rahbar Ranji, "CRITICAL analysis of stiffened plates subjected to non-uniform biaxial compressive loads using conventional and super finite elements," *Thin-Walled Struct.*, vol. 64, pp. 41–49, 2013, doi: 10.1016/j.tws.2012.12.004.
- [7] K. M. Reddy, B. S. Reddy, and R. M. Kumar, "Impact Factor: 1.852 CRITICAL Analysis of Laminated Composite Plates Using Finite Element Method," vol. 2, no. 11, 2013, [Online]. Available: www.ijesrt.com
- [8] G. S. Kakani and P. P. Prasanthi, "Prediction of Nonlinear Behavior Of Thin Skew Plates With Cut-Out Using Finite Element Analysis," vol. 1, no. 8, pp. 1–9, 2012.
- [9] B. O. Baba, "CRITICAL behavior of laminated composite plates," *J. Reinf. Plast. Compos.*, vol. 26, no. 16, pp. 1637–1655, 2007, doi: 10.1177/0731684407079515.
- [10] H. A. Ameen, "CRITICAL Analysis of Composite Laminated Plate with Cutouts دراسة," vol. 27, no. 8, 2009.