

# Hybrid Renewable Energy Generation System using Artificial Neural Network (ANN)

Madhulika dewangan<sup>1</sup>, Tanu Rizvi<sup>2</sup>, Devanand Bhonsle<sup>3</sup>

<sup>1</sup>Mtech student, Department of electrical engineering, SSTC, Bhilai

<sup>2</sup>Assistant Professor, Department of electrical engineering, SSTC, Bhilai

<sup>3</sup>Sr. Assistant Professor, Department of electrical engineering, SSTC, Bhilai

\*\*\*

**Abstract** - This study introduces a novel methodology for addressing load demands through the implementation of a dual renewable energy generation system that combines wind and solar sources. The evaluation of energy stability in the selected Scheme is performed via an Artificial Neural Network (ANN). The present investigation utilises a Multilevel Feed Forward Network (FFN), which is a form of artificial neural network, for the purpose of controlling the functioning of a hybrid renewable energy system. The resolution of the divergent operational approaches of the hybrid system in relation to time-varying factors may be accomplished with a considerable degree of ease and straightforwardness. The fuzzy logic controller, a renewable resource, is computed and transmitted to the fuzzy controller. Subsequently, the fuzzy controller utilises the received information to generate control signals for the purpose of modifying power generation. The controller exhibits a satisfactory level of intelligence to independently ascertain the suitable modifications in the operational state of the solar and wind systems in reaction to dynamic fluctuations. The proposed system is implemented with the MATLAB SIMULINK software package.

**Keywords**—Power generation system; Fuzzy logic controller; Operating point

## I. INTRODUCTION

In the context of small-scale enterprises and residential applications, there exists a requirement for alternative sources of electricity that can be sustained through the use of renewable energy. One of the primary benefits associated with the utilization of renewable energy lies in its numerous and sustainable sources, such as solar power, which harnesses the energy emitted by the sun. Additionally, renewable energy sources, such as hydrogen, provide a greater capacity for power generation due to their inherent composition. The primary energy sources encompassing solar, wind, and tidal energy are well recognized in academic discourse [1]. The use of wind and solar energy constitutes the predominant means of generating power from

renewable resources. The significance of wind power generation in India is increasing as a result of its favorable geographical location and the influence of the monsoon season, which facilitates the presence of strong wind currents. Solar energy is a plentiful and widely accessible source of electricity that can be harnessed without the need for any preprocessing techniques. There is a prevailing inclination towards the generation and regulation of electricity through the use of renewable sources, such as wind and solar energy. Solar and wind energies are subject to intermittent availability due to their reliance on climatic conditions, hence limiting their ability to provide a constant energy supply to the grid[2]. Therefore, the functionality of the system is contingent upon the presence of a storage component, such as batteries. Storing the generated electricity is not a cost-effective proposition. In order to mitigate expenses associated with investing in a storage system, a hybrid system is employed, including both solar and wind energy generation methods in response to variations in climatic conditions. In order to optimize the return on investment, it is imperative to maximize the power output from solar panels and windmills. This may be accomplished by operating the system at its optimal operating point, so ensuring the system's efficiency is maximized. Given the substantial initial investment required for these renewable energy sources, it is crucial to extract the maximum power output from them to fully capitalize on their potential. The objective of this study is to determine the optimal operating conditions in order to maximize power extraction from the solar and wind subsystems. The suggested solution involves optimizing the operation of the current wind and solar units in order to achieve their maximum power output and extract the highest possible amount of power.

A supervisor must be built for system control. The supervisor uses an ANN model to determine flywheel energy storage system energy transmission. This involves deciding whether to charge, discharge, or not transmit energy. The supervisor is also vital in detecting diesel generator ON/OFF status. These generators are carefully selected to regulate the flywheel energy storage system's motor/generator control mode and diesel generator intervention. The supervisor's inputs include hybrid system reference power, wind generator power,

and flywheel energy. Controlling and supervising the hybrid system involves achieving its power output, managing energy transfer between the hybrid system and the AC grid, optimizing wind energy use, and reducing generator diesel fuel consumption. The inputs and outputs for training the Artificial Neural Network (ANN) model were stored in a full database (Reference 4). This database covers all system situations. The Matlab "new" function trains the artificial neural network (ANN). After testing, the ANN's final parameters and architecture were determined..

A. Pv module

The solar photovoltaic (PV) module is a device that converts sunlight into electricity through the use of photovoltaic cells. Solar panels are capable of harnessing the energy of photons emitted by the sun and then converting it into electrical energy through the utilization of the photovoltaic (PV) effect principle. PV modules are manufactured using either thin-film or silicon materials. This technology offers a consistent power output at a relatively cheap expense, while also being environmentally friendly. A typical photovoltaic (PV) cell has a maximum power output of 3 watts, operating at an approximate direct current (dc) voltage of 1/2V. The configuration of photovoltaic (PV) cells, whether coupled in series or parallel, in order to form a PV module[5]..

B. Solar Cell Characteristics

The solar cell primarily consists of photovoltaic (PV) wafers that convert solar irradiation's light energy into voltage and current, enabling the powering of loads. Additionally [6], it carries electricity without any electrolytic effects. The generation of electric energy occurs by the direct use of the PN interface of the semiconductor, hence leading to the solar cell being commonly referred to as a photovoltaic (PV) cell. The schematic representation of a solar cell, as seen in Figure 1, illustrates its equivalent circuit [12].

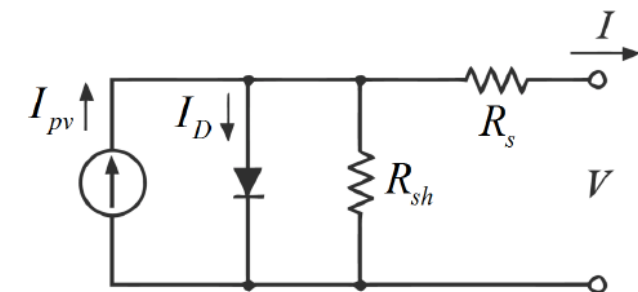

Fig.1 Equivalent circuit of PV array

The existing source The symbol "Iph" is commonly employed to denote the current generated by a photovoltaic cell. The symbol "Rj" is utilised to represent

the nonlinear resistance associated with the p-n junction. Additionally, the symbols "Rsh" and "Rs" are employed to indicate the intrinsic shunt and series resistance, respectively. Typically, the resistance value of Rsh is somewhat greater, whereas the resistance value of Rs is considerably smaller. Therefore, both of these factors might be disregarded in order to streamline the study. Photovoltaic (PV) cells are organised into bigger components known as PV modules. The PV arrays are formed by interconnecting them in a series-parallel combination[16]. The mathematical representation employed to simplify the photovoltaic (PV) array is denoted by the equation[8].

$$I = n_p I_{ph} - n_p I_{rs} \left[ e^{\left( \frac{q}{kT A} \frac{V}{n_s} \right)} - 1 \right]$$

Let I represent the current output of the photovoltaic (PV) array, V denote the voltage output of the PV array, ns signify the quantity of series cells, np indicate the number of parallel cells, q symbolize the charge of an electron, k represent the Boltzmann constant, A denote the ideality factor of the p-n junction, T signify the temperature of the cell, and Irs represent the reverse saturation current of the cell. The factor A is responsible for determining the extent to which solar cells deviate from the ideal features of a p-n junction. The value of the variable varies from a minimum of one to a maximum of five. The photocurrent, denoted as Iph, is contingent upon the solar irradiance and the temperature of the cell, as indicated in the following manner [7].

$$I_{ph} = [I_{scr} + K_i(T - T_r)] \frac{S}{100}$$

The cell short circuit current at the reference temperature and radiation is denoted as Iscr, while the short circuit current temperature coefficient is represented by Ki. Additionally, S represents the solar irradiance measured in milliwatts per square centimeter. Figure 4 displays the Simulink model representing the photovoltaic (PV) array. The model consists of three subsystems. There is a subsystem designed to represent the photovoltaic (PV) module, as well as two other subsystems intended to mimic the parameters Iph and Irs[15].

C. Wind Energy

The kinetic energy is transformed into mechanical energy by the wind turbine, which is subsequently turned into electrical energy through the use of an electrical generator [9]. Various types of generators are employed in wind power systems for the purpose of generating electrical power. These include induction generators, synchronous generators, and others. Typically, the apparatus employed in the implementation of wind energy systems consists of a

wind turbine, gearbox, and generator, along with an AC-to-DC converter [10].

PROPOSED SYSTEM

The block diagram illustrating the proposed system is seen in Figure 1.1. The windmill utilizes an alternating current (AC) power source to accumulate surplus

voltage, which is then stored in a battery by the implementation of a bridge rectifier. The solar cell produces a direct current (DC) voltage, which is then transferred straight to the battery as surplus voltage. In the current study, the focus is not just on the depletion of battery power in situations when there is an excessive demand for load[11].

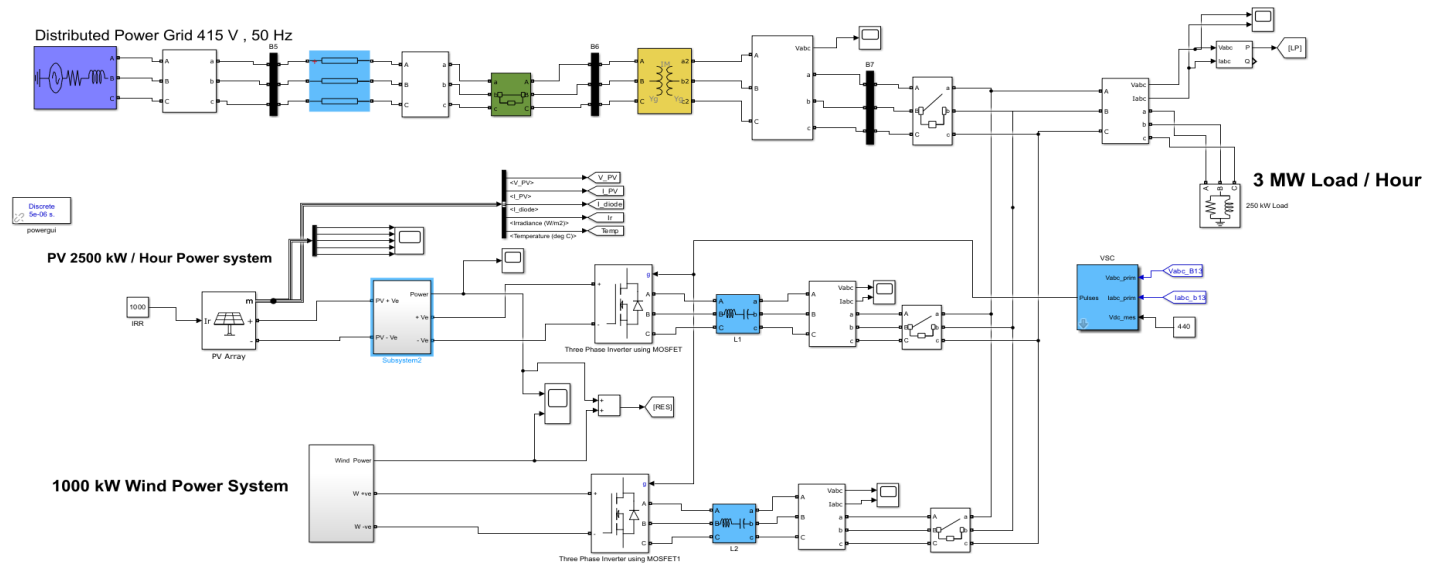

Figure1.1 Block Diagram for the proposed system.

The process of developing a hybrid renewable system the maximum power point tracking (MPPT) technique [13] is employed to ascertain the highest power output produced by photovoltaic cells. Additionally, the energy consumption of hybrid systems may be monitored either concurrently or independently, depending on the application of fuzzy logic principles [14]. The MPPT method is commonly utilized in the context of photovoltaic cells, mostly due to the nonlinear voltage-current (VI) characteristics shown by solar panels. This technique is specifically designed to identify the optimal operating point inside the PV cell array, where the highest power output may be extracted [16]. The operating point of a solar panel is contingent upon the level of irradiance it receives, which may be influenced by environmental variations, as well as the amount of heat dissipated by the panel during the power generating process. Photovoltaic (PV) arrays exhibit a voltage-current characteristic that is nonlinear in nature, with a distinct point at which the power generated reaches its maximum value [8]. The validity of this assertion is contingent upon the temperature of the panels and the prevailing irradiance circumstances. Both conditions undergo diurnal fluctuations and exhibit seasonal variations. Moreover, the level of irradiation might undergo significant fluctuations as a consequence of variations in meteorological conditions, such as the

presence of clouds. Accurate tracking of the maximum power point (MPP) is of utmost significance across all conceivable scenarios to ensure the consistent attainment of the highest available power [18]. The hybrid renewable energy system has been developed with the intention of harnessing electricity from two renewable sources, namely wind and solar energies. The hybrid system is comprised of solar, wind, and battery components. The equation for the hybrid system is shown here in.

$$Y=W+S+B$$

(1) In equation (1), Y stands for output power reference, W, S, and B stand for power generated from wind, solar, and battery sources, respectively.

a. Wind Subsystem Design

The subsystem consists of a multi-polar permanent magnet synchronous generator (PMSG) and a wind turbine. The windmill produces electrical output in the form of alternating current (AC), but the battery is designed to exclusively receive direct current (DC). In order to enable this transformation, a rectifier is employed. Furthermore, the implementation of a low pass filter is utilised, incorporating an initial direct current (DC) signal of 0.4 and an alternating current (AC)

signal characterised by a magnitude of 0.8, a phase of -25 degrees, and a frequency of 60 Hz. The inputs of the subsystem comprise a pitch angle of 0°, a base rotor speed of 12 m/s, and a wind speed of 9 m/s. Figure 1 illustrates the schematic architecture of the proposed system. The produced voltage is evaluated in comparison to a pre-established threshold value. In the event that the produced voltage decreases below the specified threshold, the fuzzy controller will be engaged to effectively manage the generating system and the flow of battery charge. The mathematical formulation of the wind subsystem in the rotor reference frame is illustrated as shown in reference [3]:

$$i_q = -\frac{R_s}{L} i_q - \omega_e i_d + \frac{\omega_e \varphi_m}{L} - \frac{\pi v b i q u w}{3\sqrt{3}L\sqrt{i2q + i2d}}$$

$$i_d = -\frac{R_s}{L} i_d - \omega_e i_q - \frac{\pi v b i q u w}{3\sqrt{3}L\sqrt{i2q + i2d}}$$

$$\omega_e = \frac{P}{2J} (Tt - \frac{3}{2} \frac{P}{2} \phi m i q)$$

In equation (2), the  $i_q$  and  $i_d$  current refer to quadrature and direct current of the rotor.

$$P_m = c_p(\lambda, \beta) \frac{\rho A}{2} v_{wind}^3 \tag{2}$$

The power characteristics shown by the turbine during the steady-state operation. The turbine's generator is equipped with an infinite drive train and inertia, while the friction factor is provided. Equation (3) represents the expression for the output power. The prime minister (PM) is responsible for overseeing the distribution of electricity generated by the turbine. The performance coefficient of the turbine is denoted as  $C_p$  [17].

### Artificial Neural Network(ANN)

Supervisory management of hybrid systems in the context of artificial neural networks. In recent years, artificial neural network (ANN) models have been extensively employed in renewable energy conversion systems, including photovoltaic (PV) systems,[20] wind systems, and hybrid systems. This article presents a proposed artificial neural network (ANN) model for the control of hybrid renewable energy systems. The control of the flywheel energy storage system necessitates the identification of an energy transfer sign based on the overall state of the system.

The creation and functioning of artificial neural networks (ANNs) The architectural configuration of an Artificial Neural Network (ANN) has three fundamental layers of neurons, specifically the input layer, the hidden layer, and the output layer. The artificial neural network (ANN) model may be observed in several topological configurations. Simpson provides an extensive analysis of many notable artificial neural network (ANN) paradigms, with thorough comparative evaluations, practical applications, and real-world implementations of these paradigms. Out of the available alternatives, the

backpropagation paradigm is the most frequently employed. Every layer (i) consists of  $N_i$  neurons that receive inputs from  $N_{i-1}$  neurons in the preceding layer. Every synapse is linked to a synaptic weight, which functions to amplify the input values ( $N_{i-1}$ ) and subsequently combine them at the neuron level i. The aforementioned procedure might be likened to the act of multiplying the input vector with a matrix of transformations. The procedure of constructing a neural network with several layers entails the sequential application of diverse transformation matrices. The simplification of this problem can be achieved by consolidating these matrices into a unified matrix. Furthermore, it is worth noting that each layer of the system integrates an output function, which serves to introduce nonlinearity at every stage. This highlights the significance of selecting an appropriate output function, as a neural network that produces linear outputs lacks value or relevance. Within the framework of backpropagation architecture, it is seen that every individual neuron is subjected to receiving inputs originating from the real-world environment[19].

The training phase of artificial neural network (ANN) development is widely regarded as a particularly captivating aspect. The initial phase of this training programme involves the creation of a database to facilitate the storage and retrieval of desired input and output data. The artificial neural network (ANN) is taught to discern and establish the correlation between input data and output data. The backpropagation algorithm employs a form of supervised training methodology. In this methodology, the starting values of the interlayer connection weights and the processing elements thresholds are set to tiny random values[20]. Prior to establishing the network, we constructed a comprehensive database that encompasses all potential scenarios that may arise inside the hybrid system. The artificial neural network (ANN) model employed consists of a total of two input nodes and two output nodes. The input consists of two nodes, namely  $P_{ref}$  -  $P_{wind}$  and the X parameter. The output consists of two nodes, namely "ksign" and "kstat".

### Architecture of Artificial Neural Network

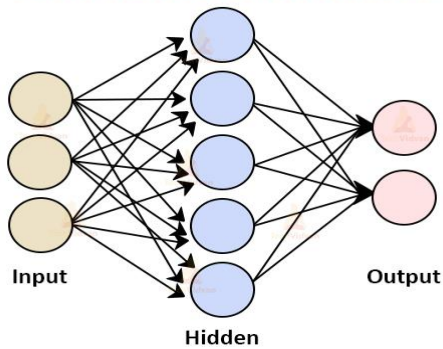

Fig.4 -The architecture of the ANN model.



Figure 7. Analysis of the battery.

### SIMULATION RESULTS

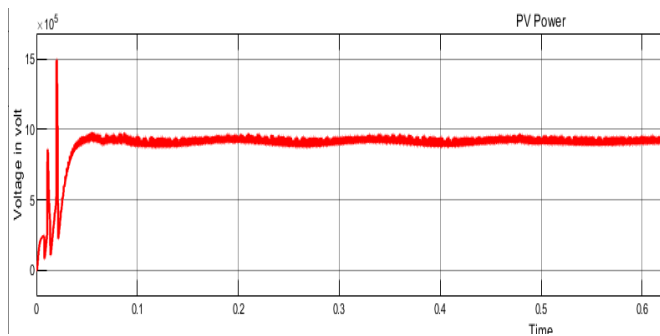

Fig5: The power generated by Solar Power

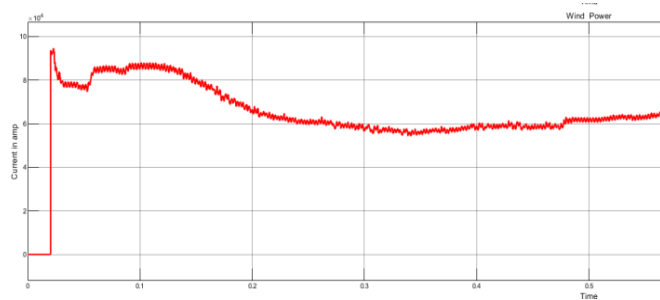

Fig 6: The power generated by Wind Power

Figures 5 and 6 present an illustration of the power generation resulting from the use of wind energy and solar energy, respectively. The total amount of electricity that can be generated by the hybrid systems is equal to 2200 kilowatts. Figure 7 provides a visual representation of the dynamic temporal evolution and current charge status of the battery. This depiction includes both the activation and discharge processes.

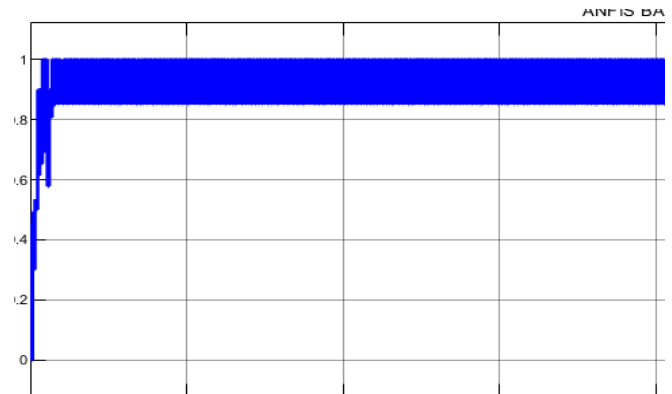

Figure 8. Control of the voltage at the PWM.

The process of regulating the voltage in the inverter is depicted in Figure 8. Figure 9 demonstrates that the controller has successfully satisfied the requirements for a variety of load scenarios, including those with 0%, 50%, and 100% of the load. The power that is active and reactive inside the hybrid systems is represented by the red line, while the power that is stored in the battery is depicted by the yellow line. The electricity generated by each of the hybrid systems is depicted in the previous two lines..

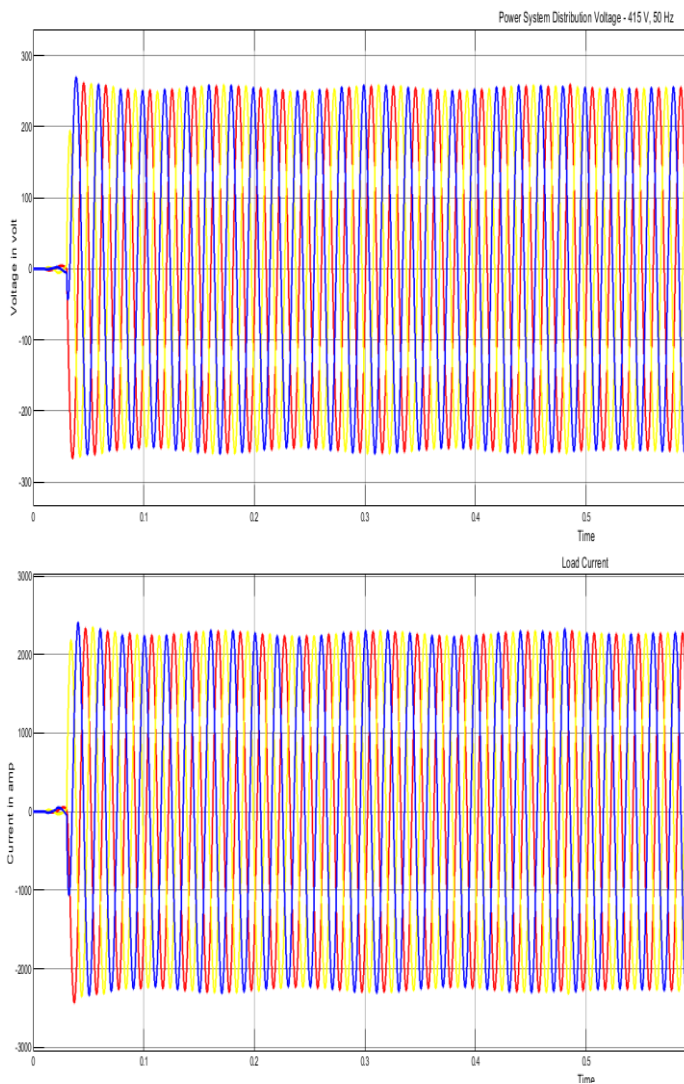

Figure 9(a-b): Existing MPC controller (a) and proposed system (b) power generation and consumption under varying loads.

Figure 9 (a) depicts the implementation of Model Predictive Control (MPC) under varying load situations. Between time steps 0.05 and 0.8, the power output is observed to decrease below the reference power level, leading to the depletion of the battery to meet the power need of 9000 units. In Figure 9(b), the control mechanism of the proposed system is depicted. During the time interval from ts 0.3 to 0.5 seconds, the generated power exhibits a decline below the reference power value of 22000. Consequently, the controller initiates the discharge of the required power from the battery. The figure presented in Figure 10 illustrates the power generated by the system under various load situations, as well as the system's reaction to changes in reference power. These measurements were conducted throughout several time windows, accounting for variations in both solar and wind energy.

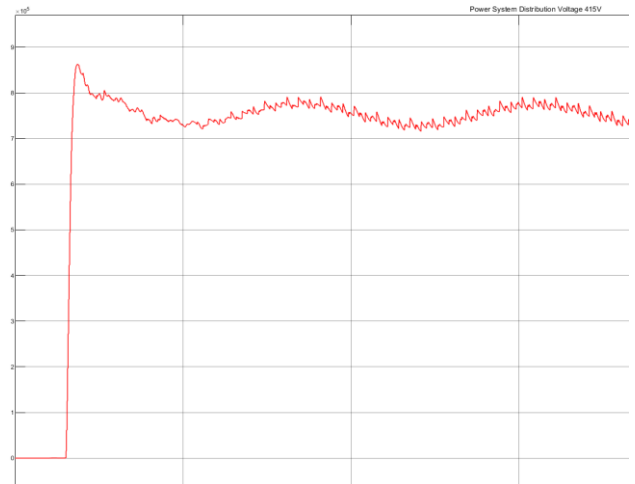

Figure 10. The amount of energy produced by the proposed system throughout various time periods.

## CONCLUSION



In this study, we suggest using an ANN to regulate a hybrid setup. The suggested framework is superior to existing solutions for energy management and efficient hybrid system operation. The article outlines the process of creating the three subsystems, a controller that regulates the hybrid system's power management, and an illustrated overview of the system's results. This study proposes and models a hybrid renewable energy system, and then determines the local control techniques that will be used for the various subsystems that make up energy production. In order to achieve efficient utilization of wind energy and reduce fuel consumption of diesel generators, a supervisor is developed based on an artificial neural network model. This supervisor is meant to regulate the system and ensure that the power required by the AC grid is met. Subsequently, the use of Mat lab Simulink is employed to validate the control regulations. The issue of managing consumption and production in wind generators, which are decentralized sources of energy, can potentially be addressed by the implementation of a hybrid renewable energy system and its corresponding control mechanisms. This assertion is supported by the findings obtained from the simulation results. This method increases the proportion of wind generators in power grids without endangering the reliability of such networks, and so enhances the quality of wind power.

## REFERENCE

- [1] Wei Qi, Jinfeng Liu, Xianzhong Chen, and Panagiotis D. Christofides, "Supervisory Predictive Control of Standalone Wind/Solar Energy Generation Systems, IEEE TRANSACTIONS ON CONTROL SYSTEMS TECHNOLOGY, VOL. 19, NO. 1, JANUARY 2011.

- [2] LI Suzhen, LIUXiangjie, YUANGang, "Application of Hierarchical Control in Supervisory Predictive Control", Proceedings of the 33rd Chinese control conference July 28-30, 2014, China.
- [3] Doris S´aez, Senior Member, IEEE, Freddy Milla, Member, IEEE, and Luis S. Vargas, "Fuzzy Predictive Supervisory Control for Gas Turbines of Combined Cycle Power Plants.
- [4] V. Yaramasul, B. Wul, M. Rivera, and J. Rodriguez, "Enhanced Model Predictive Voltage Control of four-leg Inverters with Switching Frequency Reduction for Standalone Power Systems.
- [5] Amir borough and Sadegh borough "Different Kind of Renewable Energy and exergy Concept" International journal of multidisciplinary sciences and engineering Vol.2, No.9, December 2011
- [6] Zuhairuse Md Darus, Nor Atikah Hashim, Sitig Nurhidayah Abdul Manan, Mohd Azhar Abdul Rahman, Khairul Nizam Abdul Maulud, and Othman Abdul Karim, " The Development of Hybrid Integrated Renewable Energy System (Wind and Solar) for Sustainable Living at Perhentian Island, Malaysia", European Journal of Social Sciences, Vol.9, No.4, pp.557563, 2009
- [7] Onyemaechi Chukuezi, "Gender and renewable energy in rural Nigeria", International NGO Journal Vol.4, No.7, pp.333-336, July 2009
- [8] Md.Zakaria Mahbub, Husnain-Al-Bustan, M.M.Suvro Shahriar, T.M. Iftikhar Uddin, and Md. Abrar Saad, "Comparison between Conventional Power Generation and Renewable Energy Power Generation In Bangladesh", International journal of engineering research and applications (IJERA), Vol.2, No.2, pp.896-902, Mar-Apr 2012
- [9] J Ding and J S Buckeridge "Design considerations for a sustainable hybrid energy system" IPENZ Transactions, Vol.27, No.1, May 2000
- [10] J. A. Peças Lopes, F. J. Soares, P. M. Almeida and M. Moreira da Silva "Smart Charging Strategies for Electric Vehicles: Enhancing Grid Performance and Maximizing the Use of Variable Renewable Energy Resources" EVS24 Stavanger, Norway, pp.1-11, May 2009
- [11] Rizvi. T.,Dubey. S. P.,Tripathi. N. and Makhija. S. P.2023. FSPV-Grid integrated system for efficient electrification of industrial subsections with grid price sensitivity analysis.IEEE Sponsored Second International Conference on Advances in Electrical, Computing, Communications and Sustainable Technologies (ICAECT 2023).
- [12] Rizvi. T.,Dubey. S. P.,Tripathi. N. and Makhija. S. P.2022.A Comparative Analysis of FSPV-Grid and Grid-only systems for an Industrial Subsection.IEEE Sponsored Second International Conference on Advances in Electrical, Computing, Communications and Sustainable Technologies (ICAECT 2022).
- [13] Rizvi. T.,Dubey. S. P.,Tripathi. N.,Srivastava.S., Makhija. S. P. and Mohiddin. Md. K.2023.FSPV-Grid system for an Industrial subsection with PV price sensitivity analysis. Sustainability2023,15(03):1-18.
- [14] Rizvi. T.,Dubey. S. P. and Tripathi. N.2021.Designing of a Feasible Low Pollutant Grid Integrated System for Steel Plant. CSVTU Research Journal, 10(02):144-154.
- [15] Rizvi. T.,Tripathi. N. and Dubey. S. P. 2020 Feasibility Analysis of a Grid Integrated Renewable Energy Systems in Heavy Industries. Jour of Adv Research in Dynamical & Control Systems (JARDCS),12(06):2289-2302.
- [16] Rizvi. T.,Dubey. S. P. and Tripathi. N.2022.Reconceptualizing the Application of Renewable Energy Sources in Industry: A Review. International Research Journal of Engineering and Technology (IRJET), 09(01):514-518.
- [17] Nirmal. S. & Rizvi. T.2022.A Review of Renewable Energy Systems for Industrial Applications. International Journal for Research in Applied Science & Engineering Technology (IJRASET), 10(9): 1740-1745.
- [18] Chandra. S. & Rizvi. T. 2022.Detailed Energy Audit of Thermal Power Plant. International Journal for Research in Applied Science & Engineering Technology (IJRASET), 10(5): 1836-1846.
- [19] Chandra. S. & Rizvi. T. 2022. Energy Audit of Thermal Power Plant : A Literature Survey i-Manager Journal on Power System Engineering, 09(04): 36- 40.
- [20] Verghese.M. and Rizvi. T. 2023.Optimal DG Placement for Loss Minimization and Voltage Profile Improvement using Optimization Techniques: A Review, International Journal of Innovative Research in Engineering (IJIRE),4(2):359-363.

**BIOGRAPHIES**

S. No.	Name	Bibliography	Photo
1	Madhulika dewangan	<b>Madhulika dewangan</b> has done her B.E in Electrical engineering in 2017 from Parthivi college of engineering and management bhilai( Chattishgarh swami vivekanand technical university, bhilai). Currently she is doing her MTech in power system engineering from SSTC bhilai.	
2	Ms. Tanu Rizvi	Tanu Rizvi received her B.E. in Electrical & Electronics Engineering(EEE) from Pt. Ravishankar Shukla University, Raipur in 2008, M. E. in Power System Engineering (EE) from CSVTU, Bhilai in 2013 and pursuing PhD in EE from CSVTU, Bhilai. Presently She is working as Assistant Professor in SSTC, Bhilai since 2008. Her area of research is renewable energy. She published many research papers in various journals and conferences. She contributed 2 book chapters in reputed publications. She is college level coordinator of spoken tutorial IIT Bombay and professional member of IFERP.	
3	Dr Devanand Bhonsle	<b>Dr. Devanand Bhonsle</b> received his B.E. in Electronics & Telecommunication (ETC) from Pt. Ravishankar Shukla University (PRSU), Raipur in 2004, M. E. (ETC) from CSVTU, Bhilai in 2008 and Ph.D. (ETC) from CSVTU, Bhilai in 2019. Recently he is working as Sr. Assistant Professor in Shri Shankaracharya Technical Campus (SSTC), Bhilai with experience of 17 years. His research area is digital signal and image processing. He published 45 research papers in various journals and conferences. He contributed 4 book chapters in reputed publications. He is the reviewer in IEEE access, IET image processing, Electronics letters and IGI global publications. He is the professional member of IFERP.	