

# Design and Fatigue Analysis of a Typical Aircraft Wing fuselage Lug attachment structure

Sonu Kumar<sup>1</sup>, Amit Kumar Jha<sup>2</sup>, G R Kesheorey<sup>3</sup>

<sup>1</sup> M. tech Student, Department of Mechanical Engineering, Vindhya Institute of Technology & Science Indore (MP)

<sup>2</sup> Senior Manager, Hindustan Aeronautics Limited, Bengaluru

<sup>3</sup> Professor, Department of Mechanical Engineering, Vindhya Institute of Technology & Science Indore (MP)

\*\*\*

**Abstract** - The structure of a fighter jet is quite complicated. The aeroplane is required to do challenging manoeuvres while fighting off enemies. During that, high magnitude stresses will be placed on the wings as a result of the combination of high level acceleration and challenging maneuvers. The fighter aircraft often has multiple wing-fuselage attachment points. An aircraft rarely has a static overload-related failure during its service life. Fatigue and damage tolerance design, analysis, testing, and service experience correlation are crucial for maintaining an aircraft's airworthiness during its entire economic service life. The fatigue loading that occurs during service on lug type joints completes load transmission through the pin. This is why the wing-fuselage lug joints are regarded as the aircraft structure's most fracture-critical parts.

In the current project, an attempt is made to predict the fatigue life of a wing-fuselage attachment bracket of a fighter aircraft to meet the stress and fatigue design considerations. Subsequently, linear static analysis is carried out. The stress results of finite element analysis show that stress levels of lug structure meet the strength requirement. Furthermore, utilizing constant amplitude S-N data for various stress ratios and local stress history at stress concentration, fatigue life computation is carried for a typical service loading. The lug structure's computed damage factor for the given load spectrum comes out to be less than one. This demonstrates that the wing lug structure is safe to use and that the crack has not initiated.

**Keywords:** Fatigue life, Damage, Aircraft, Wing, Lug design, Static analysis.

## 1. INTRODUCTION

An aircraft is a sophisticated human-made flying machine that serves that function. The fuselage, wings, empennage, landing gear, power supply, and control surfaces are depicted in Fig. 1 as the majority of the aircraft's components [1].

Wings and the fuselage are joined by lugs, which are also used to join engines to engine pylons, flaps, ailerons, and

spoilers to the wings. For receiving large, focused loads, lug joints are frequently employed. Additionally, while in use, lug-type joints experience cyclic loading; all loads are transmitted through the pin. During cyclic loading, high-stress concentration and fretting at the pin-to-lug interface may lead to fracture initiation and crack growth. As a result, the wing-fuselage lug connection of a typical aircraft can be analyzed using finite element static analysis and fatigue life computation.

Previously, lugs connecting to wing-fuselage and vertical tail-fuselage for an aircraft airframe structure defined geometry was submitted to finite element analysis [2-3]. As a result of the fast acceleration and complicated motions, the wing surface will be subjected to severe loads [4]. The root of the wing will experience the highest stress concentration due to the maximum bending moment [5]. Brackets are used to attach the wings to the fuselage framework. The bending moment and shear stresses of the wing were transferred to the fuselage by these attachments [6]. Furthermore, fatigue is the continuous decrease of structural component strength during operations, with failure occurring at much lower levels of ultimate stress. This is due to the fact that repeated loads operate for a longer period of time. Based on static structural analysis, fatigue life calculations utilising the stress life technique and Goodman's criterion predict that the geometry is safe [7]. As a result, the wing-fuselage lug attachment structure is designed using a finite element analysis and fatigue life calculation approach.

## 2. METHODOLOGY

The present work is focused on the modeling and the static analysis of aircraft wing fuselage attachment lugs. Additionally, fatigue life estimation is also carried out to study the behaviour of lugs because of repeated cyclic loading. The methodology and workflow carried out in the present work are as shown in Fig 2.

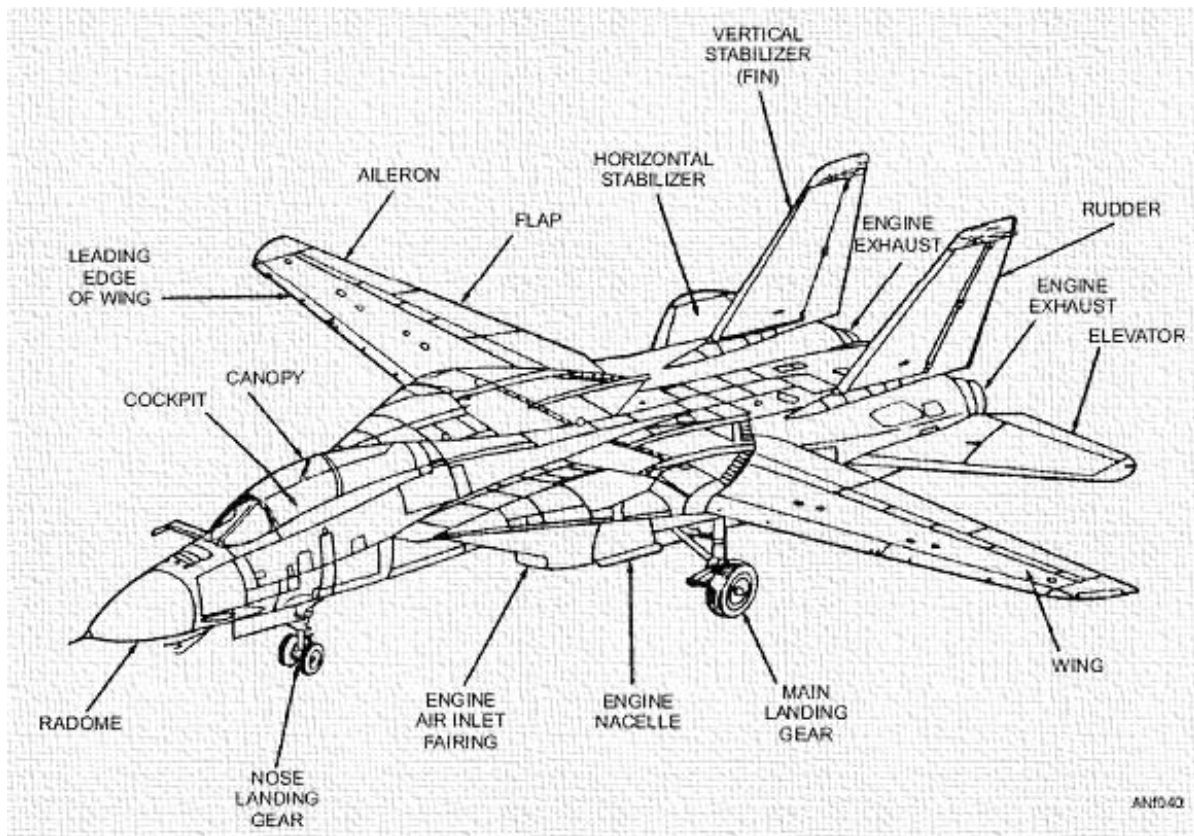

Fig- 1: aircraft with components [1]

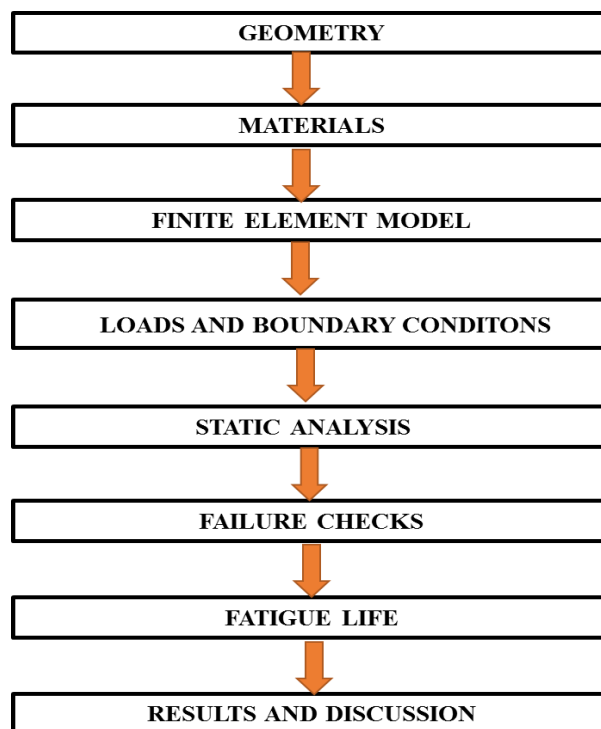

Fig- 2: Static and Fatigue life methodology

### 2.1 Geometry configuration

The geometric dimensions of the wing fuselage lug attachment bracket is shown in Fig 3.

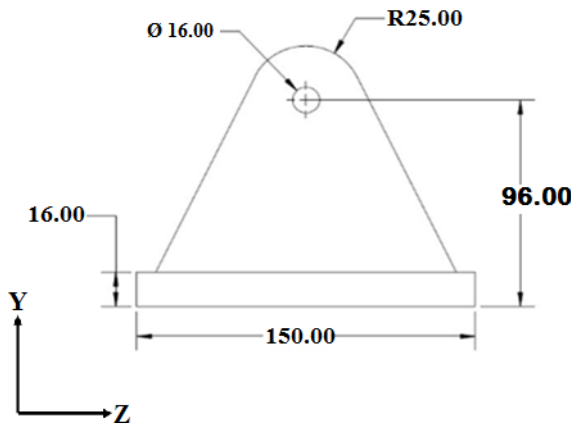

Fig-3: Front view of a wing fuselage lug attachment (mm)

A three dimensional view of the lug attachment bracket is shown in Fig 4.

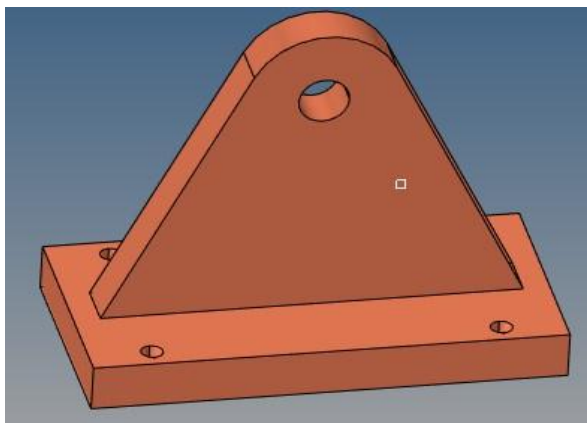

Fig- 4: Three dimensional model of LUG Bracket

### 2.2 Materials

The combination of strength and lightweight is most important in material selection in aeronautical applications [8]. In many cases, trials and errors can be costly, thus a proper project and design are vital. As a result, the following material properties should be considered for structural applications [9-10]:

**Elasticity:** It is the property by virtue of which a material deformed under the load is enabled to return to its original dimension when the load is removed. Some examples are Mild Steel etc. and may be considered to be perfectly elastic within a certain limit.

**Ductility:** It is the property which permits a material to be drawn out longitudinally to a reduced section, under the action of tensile force.

**Yield stress:** The yield stress is a measure of elastic deformation resistance. In structural applications, yield stress is usually more critical than tensile strength because once it is exceeded, the structure has deformed over and above acceptable limits. The material follows the stress up to the hooks law, also known as the proportionality limit, where stress equals strain and is known as Yield stress.

**Ultimate stress:** When the lower yield point is crossed out, there is a gradual increase in stress with respect to the strain; this increase follows the parabolic curvature until failure, but failure occurs at a point where it is going down the uppermost part of the gradually increasing curve, which is the point of ultimate Stress.

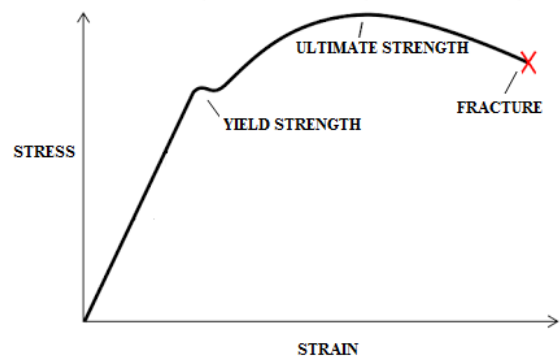

Fig- 5: Stress Vs strain [9]

Table- 1: Material Properties of an aircraft wing lug [8, 11]

Material	Parameters	Values
Aluminum Alloy – 2024- T3	Young's Modulus (N/mm <sup>2</sup> )	70000
	Poison's Ratio	0.30
	Density (Rho) (kg/mm <sup>3</sup> )	2800
	Ultimate Tensile Strength (σ <sub>ult</sub> ) (N/mm <sup>2</sup> )	485
	Yield Stress(σ <sub>y</sub> ) (N/mm <sup>2</sup> )	345
	Ultimate Shear Strength (σ <sub>sult</sub> ) (N/mm <sup>2</sup> )	291

	Ultimate Bearing Strength ( $\sigma_{bult}$ ) (N/mm <sup>2</sup> )	582
NCM Steel	Young's Modulus (N/mm <sup>2</sup> )	210000
	Ultimate Tensile Strength ( $\sigma_{ult}$ ) ((N/mm <sup>2</sup> ))	1230

### 2.3 Finite Element Model

#### MSC Patran

MSC Patran is a general-purpose analysis software package with open architecture and interactive graphics that provides a complete computer aided engineering environment for linking engineering design, analysis, and result assessment activities. It is a simulation software environment that aids engineers in the conceptualization, development, and testing of product designs [12]. MSC Patran integrates design, analysis, and outcome evaluation into a single environment. There are pre- and post-processing tools, and sophisticated simulations may be done on virtual components, assemblies, and structures. MSC Patran allows engineers to directly import CAD (computer aided design) geometry from a defining CAD programme of their choice, create meshes, define loads, boundary conditions, visualise the results, and ultimately better understand the relationship between various design decisions and product performance characteristics such as stress, strain, vibration, heat transfer, and many more [12]. MSC Patran users may easily and effectively iterate and analyse various design options, as well as reuse previous designs and findings, without the need for non-value-added manual data cleaning and recreation. MSC Patran can help organizations to reduce the cost and confusion of maintaining various pre- and post-processing techniques used throughout the company to improve goods and accelerate time to market.

#### MSC Nastran

MSC. Nastran is a powerful, general purpose finite element analysis tool with an integrated user interface and model editor which is used to analyse linear and nonlinear stress, dynamics, and heat transfer characteristics of structures and mechanical components [12]. It offers combined sizing, shape, and topology to improve overall design efficiency and lifecycle performance predictability. MSC Nastran captures the complex interactions between multiple disciplines to ensure accurate stimulation of physical phenomena, enabling engineers to correctly stimulate how a design behaves under real-world conditions without having to

solely rely upon costly physical prototypes. It is ideal for highly-engineered products such as automobiles, airplanes, heavy equipment, electronics and other complex products [12].

#### Mesh

Mesh creation is the processing of creating finite elements from curves, surfaces, or solids. MSC PATRAN provides the following automated meshes: isoparametric mesh, Paver, and Tetrahedral (Tet) mesh [12-14]. The lug bracket is meshed using Tet mesh as shown in Fig 5 and tabulated in Table 1.

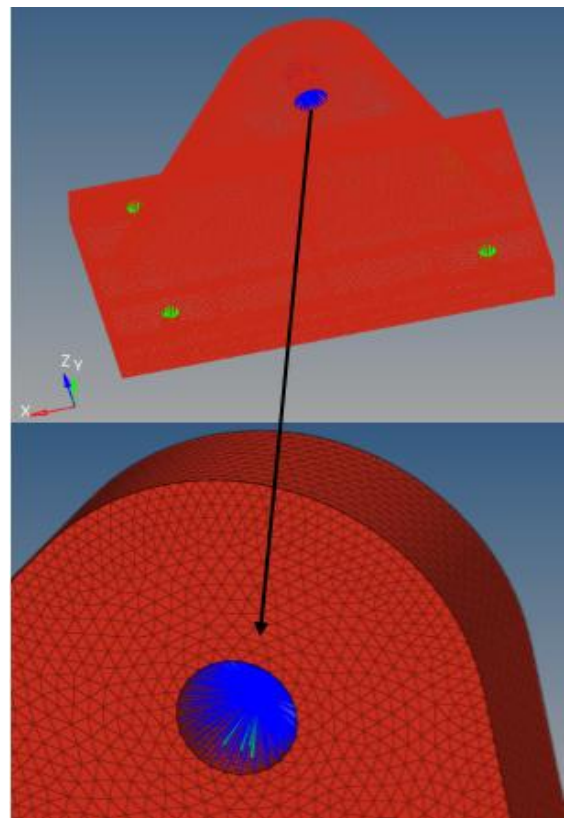

Fig- 6: LUG Bracket mesh

Table- 2: Elements and Nodes Count

Total number of nodes	60314
Total number of elements	296801
Element type	Tetrahedral

### 2.4 Loads and boundary conditions

There are different types of loads acting on an aircraft, such as surface forces, body forces [8]. It can be shown as a schematic chart as below in Fig 6.

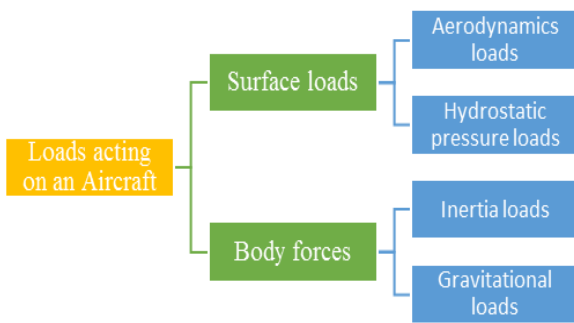

**Fig- 7:** Loads acting on an aircraft

In Fig 7, it depicts the load and boundary conditions applied to the wing fuselage lug attachment bracket [8, 12-14]. The resultant force operating at the bracket's root is computed using a "6g" load factor with factor of safety (FOS) 1.5.

Force in Y direction =  $F_y = 97060 \text{ N}$

Force in Z direction  $F_z = 10613 \text{ N}$

Resultant force =  $F_r = 97638.51 \text{ N}$

The load is distributed to the lug structure by RIGID BODY ELEMENT (RBE3)[12-14]. As maximum lift is created in the wings during take-off, it is injected at one end of the spar beam in an upward direction. At the bracket's root, where the wing and fuselage will be joined, this load will effectively provide the necessary bending moment. All six degrees of freedom are restricted to the semi-circular circumferential area between the top and bottom lug holes of the wing fuselage lug attachment bracket. The centre of bolt holes is connected to the lug structure by RIGID BODY ELEMENT (RBE2)[12-14].

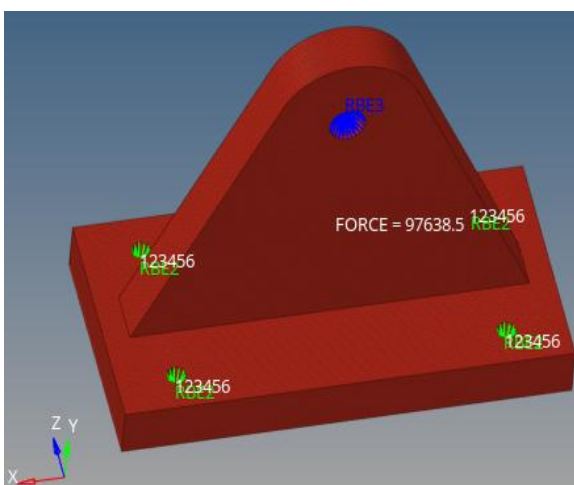

**Fig- 8:** Loads and Boundary Condition

## 2.5 Static analysis

A linear static analysis is one in which a linear relation exists between the applied forces and displacements [12-15]. In practise, this applies to structural problems where stresses remain within the linear elastic range of the material being employed. A static analysis (SOL 101) run can be configured to validate finite element model findings such as displacements, deformation, and stress.

## 2.6 Failure checks

Lug and connected bolt analysis involves several failure modes, associated with different areas of the lug[8,14,16]:

### 2.6.1 Bolt shear ( $\sigma_s$ )

$$\sigma_s = \frac{F_r}{2 \cdot A} \text{ MPa,}$$

where, Area of bolt =  $A = \frac{\pi}{4} \cdot d^2$ ,

and,  $d$  = Diameter of bolt (mm)

### 2.6.2 Tension tear out ( $\sigma_t$ )-Lug

$$\sigma_t = \frac{F_r}{(W-D) \cdot t} \text{ MPa,}$$

where, Width of lug =  $W$  (mm)

and, Diameter of lug =  $D$  (mm)

$$\text{Reserve Factor (RF)} = \frac{\sigma_{tult}}{\sigma_t}$$

### 2.6.3 Shear tear out ( $\sigma_s$ ) -Lug

$$\sigma_s = \frac{F_r}{2 \cdot a \cdot t} \text{ MPa,}$$

where,  $a$  = Shear out distance (mm),

and,  $t$  = Thickness of lug

$$\text{RF} = \frac{\sigma_{sult}}{\sigma_s}$$

### 2.6.4 Bearing out ( $\sigma_b$ )-Lug

$$\sigma_b = \frac{F_r}{D \cdot t} \text{ MPa,}$$

$$\text{RF} = \frac{\sigma_{bult}}{\sigma_b}$$

## 2.7 Fatigue life

Fatigue is the phenomenon of progressive rupture, an element under the influence of fluctuating cyclic loads. In

materials science, fatigue is a process whereby a material is weakened by cyclic loading [16-18]. The resulting stress may be less than the ultimate tensile stress, or even the yield stress of the material, but may still cause catastrophic failure[16-18]. There are various techniques for plotting the results of the fatigue failure test of a member subjected to fluctuating stress. One of them is called the modified Goodman diagram and is shown in Fig 9 [11]. For this diagram the minimum stress is plotted on the abscissa and the maximum stress components on the ordinate.

### 2.7.1 Fatigue occurrence and objective

Fatigue occurs when a material experiences lengthy periods of cyclic or repeated loads [17-20]

- Fluctuating Loads
- Multi-axial Loading
- Vibrations / Excitations

Fatigue objective is to calculate life of structure when it is subjected to repetitive load / random load.

### 2.7.2 Fatigue damage

The failure happens primarily in three stages: fracture initiation, crack propagation, and catastrophic overload failure[17-20]. For fatigue estimates, a damage tolerant design criteria and stress-life techniques were used. Constant amplitude loading is preferable for fatigue calculations. Variable amplitude loads will operate in the issue, but they will be converted to groups of constant amplitude loading at their respective frequencies. If the loading has a constant amplitude, the number of cycles before the part fails due to fatigue is represented.

**Palmgren Miner's Rule** is used to calculate fatigue life for crack initiation as expressed by equation 1[17-18]

Miner's rules:

$$D = \sum \frac{n_i}{N_i} = C \quad \dots (1)$$

where,

D = damage and C = constant equal to 1,

n<sub>i</sub> = number of cycles at a particular stress and,

N<sub>i</sub> = the fatigue life at that stress.

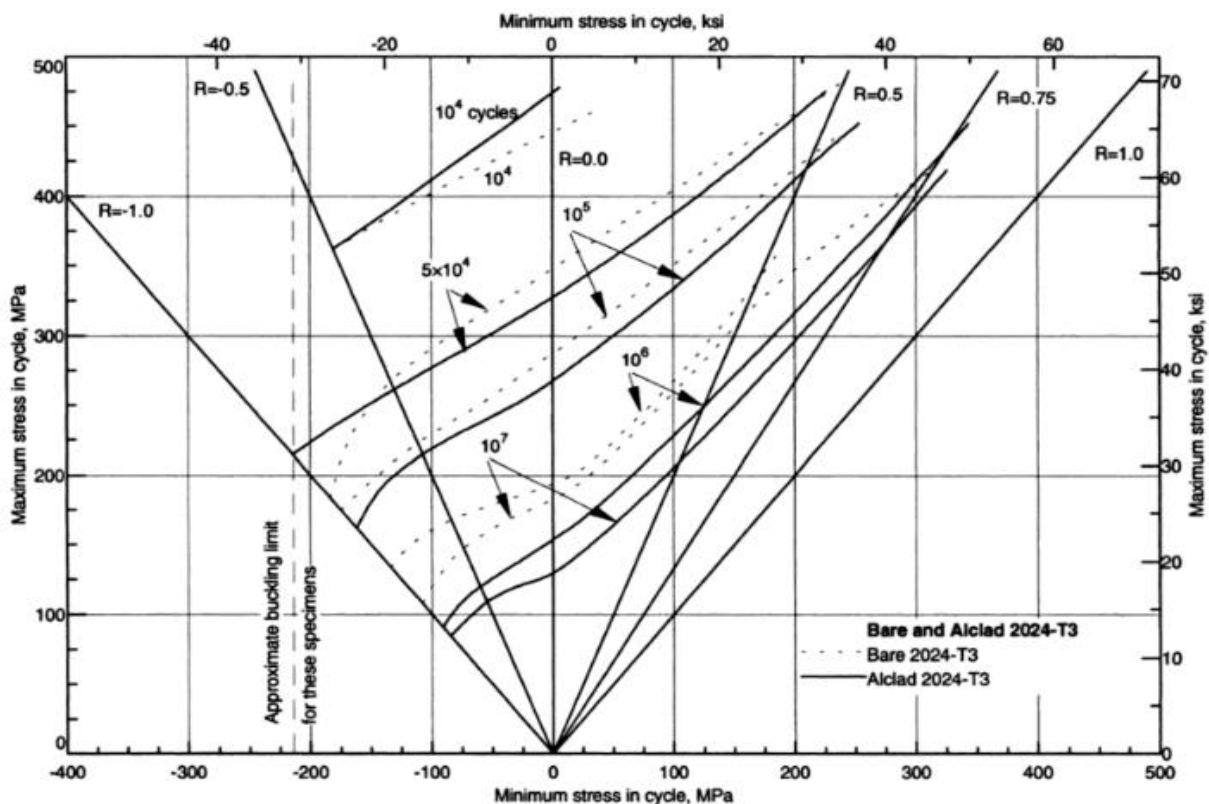

Fig- 9: 2024-T3 modified Goodman diagram (Source Alcoa 1957)[11]

## 2.8 Results and discussion

### 2.8.1 Static analysis

Results of static analysis of the lug are explained in this section. Additionally, convergence criteria for maximum principal stress vs element length is also studied as shown in Fig 10 and Table 3, respectively. Stress values at the lug attachment bracket connecting the bolt hole and the displacement contours are shown in Fig 11 and 12, respectively. The maximum stress near the hole in the connecting bolt of the lug attachment bracket is 463.166 N/mm<sup>2</sup> and 1.459 mm is the total deformation.

**Table- 3:** Convergence criteria of the Lug Joint bracket [5]

Element length (mm)	$\sigma_{max}$ (N/mm <sup>2</sup> )
0.8	367.644
1	367.602
1.5	370.663
2	301.229
3	240.509
4	236.348
6	275.937
8	258.687

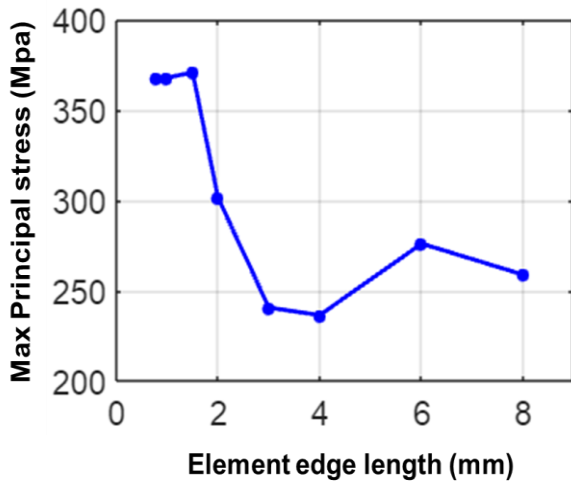

**Fig- 10:** Max. Principal stress (N/mm<sup>2</sup>) V/s element length (mm) [5]

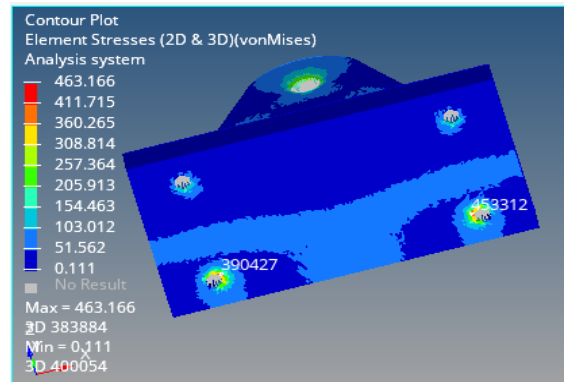

**Fig- 11:** Maximum Stress in Lug Bracket (MPa)

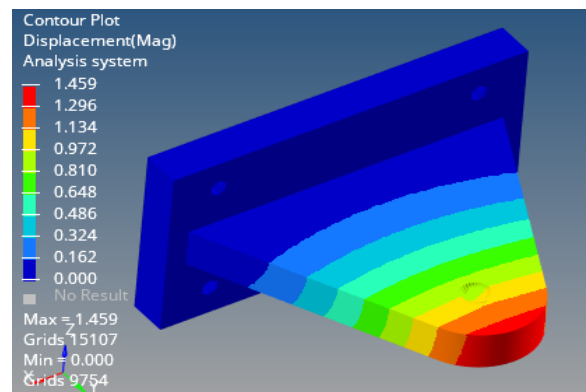

**Fig -12:** Maximum displacement in Lug Bracket (mm)

### 2.8.2 Failure analysis

Forces used in lug design are given below:

Force in Y direction =  $F_y = 97060$  N

Force in Z direction  $F_z = 10613$  N

$$\text{Resultant force} = F_r = \sqrt{97060^2 + 10613^2} = 97638.51 \text{ N}$$

$$\text{Tensile stress} = \sigma_t = \frac{F_r}{\frac{\pi}{4} * d^2}$$

$$d = \sqrt{\frac{4 * F_r}{\pi * \sigma_t}} = \sqrt{\frac{4 * 97638.51}{3.14 * 485}} = 16 \text{ mm}$$

#### Failure Check for Bolt Shear (NCM Steel)

$$\sigma_t = \frac{F_r}{2 * A}, \text{ where, } A = \frac{\pi}{4} * d^2,$$

$$\text{Substituting, } \sigma_t = \frac{F_r}{2 * \frac{\pi}{4} * d^2} = \frac{97638.51}{2 * \frac{\pi}{4} * 16^2} = 242.93 \frac{\text{N}}{\text{mm}^2}$$

$$\text{Reserve Factor (RF)} = \frac{\sigma_{\text{out}}}{\sigma_t} = \frac{738}{242.93} = 3.03 > 1$$

**Failure due to tension tear out**

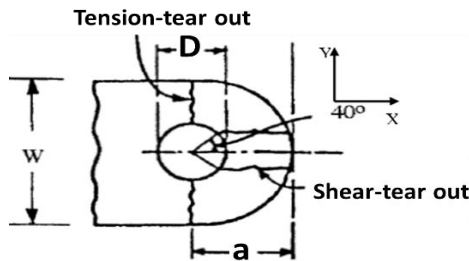

**Fig- 13:** Lug tension and Shear-tear-out [8]

Tension tear out is calculated as expressed in Fig 13:

$$\sigma_t = \frac{Fr}{(W-D)*t} = \sigma_t = \frac{97638.51}{(45-16)*16}$$

where, W = 45 mm & D = 16 mm

$$\sigma_t = 210.43 \frac{N}{\text{mm}^2}$$

Reserve Factor (RF):

$$\text{RF} = \frac{\sigma_{\text{out}}}{\sigma_t} = \frac{485}{210.43} = 2.30 > 1$$

**Failure due to shear tear out**

Shear tear out is calculated as expressed in Fig 13:

$$\sigma_s = \frac{Fr}{2*a*t}$$

where, a = 16.2 mm,

$$\sigma_s = \frac{97638.51}{2*16.2*16} = 188.35 \text{ N}$$

$$\text{Reserve Factor} = \frac{291}{188.35} = 1.55 > 1$$

**Failure due to bearing**

$$\sigma_b = \frac{Fr}{D*t} = \frac{97638.51}{16*16} = 381.4 \frac{N}{\text{mm}^2}$$

$$\text{Reserve Factor (RF)} = \frac{582}{381.4} = 1.53 > 1$$

**2.8.3 Fatigue calculation**

Lug component is subjected to cyclic loading, a fatigue crack will initiate at the point of maximum tensile stress. According to the results of the stress study of the wing fuselage lug bracket, maximum stress point is at one of the lug connecting bolt location. The fatigue load spectrum is tabulated in Table 4 and Table 5, respectively.

**Table- 4:** Fatigue Load

Finite element analysis of lug attachment bracket results- at 6g		
Maximum (ultimate)	370.66	Mpa
Stress (Limit)	247.10	Mpa
Stress (Limit)	35.84	ksi

**Table- 3:** Fatigue damage results from load spectrum and corresponding stress

g max	g min	Occurrences (Ni)	Smax	Smin	Stress Ratio	Seq	Fatigue life cycle (Nf)	Damage (ni)
6	-2	150	35.84	-11.95	-0.33	20.81	>10^6	1.500E-04
5.5	-1.8	250	32.85	-10.75	-0.33	19.03	>10^6	2.500E-04
5	-1.75	350	29.86	-10.45	-0.35	17.45	>10^6	3.500E-04
4.5	-1.4	450	26.88	-8.36	-0.31	15.47	>10^6	4.500E-04
4	-1.26	5000	23.89	-7.53	-0.32	13.77	>10^6	5.000E-03
3.5	-0.7	20000	20.91	-4.18	-0.20	11.49	>10^6	2.000E-02
3	-0.15	15000	17.92	-0.90	-0.05	9.19	>10^6	1.500E-02
2.5	0.3	12000	14.93	1.79	0.12	6.99	>10^6	1.200E-02
2	0.6	10000	11.95	3.58	0.30	4.96	>10^6	1.000E-02
1.5	0.74	25000	8.96	4.42	0.49	3.15	>10^6	2.500E-02
TOTAL DAMAGE								8.820E-02



As from Table 5, the overall damage calculated to the structure is found to be  $8.820E-02 < 1$ . According to Miner's rule if damaged is less than 1 then material is safe. So for all the given fatigue load spectrum the wing fuselage lug bracket is safe and no crack initiation takes place.

### 3.CONCLUSION

The report presents the static analysis and fatigue life estimation of an aircraft wing lug structure to meet the stress and fatigue design considerations. Finite element model is prepared with TET4 elements of lug structure for static analysis. Subsequently, linear static analysis is carried out. The stress results of finite element analysis show that stress levels of lug structure meet the strength requirement. Furthermore, fatigue analysis was carried out to estimate the damage factor. The results of the calculated damage factor of the lug structure for the specified load spectrum is less than one. That shows, there is a safe life design of the wing lug structure and the crack is not initiated.

Future work, which includes optimization, ground testing, and dynamic analysis of the wing lug structure can be planned for further study.

### ACKNOWLEDGEMENT

I am thankful to my friends for their support during my project work.

### REFERENCES

- [1] Metallic Materials for Aerospace Industry, Retrieved from <https://studycorgi.com/metallic-materials-for-aerospace-industry>, September 2022.
- [2] R. S. Harish, et al "Topology Optimization of Aircraft Wing Fuselage Lug Attachment Bracket," International Journal of Innovative Science and Research Technology, Vol. 7, Issue 3, 2022, pp. 274-278,
- [3] K. Siva Sankar, B. Ajnaneyuilu, "Design and Analysis of Lug Joint in an Airframe Structure using Finite Element Method," International Journal of Research in Engineering, Science and Management, Vol. 2, Issue 9, 2019, pp 177-186.
- [4] T.R. Brussat, K. Kathiresan and J.L. Rudd, Damage tolerance assessment of aircraft attachment lugs., Lockheed California Company, Burbank, CA 91520, U.S.A., AT&T Bell Laboratories, Marietta GA 30071, U.S.A., AFWAL/FIBEC, Wright-Patterson Air Force Base, OH 45433, U.S.A.
- [5] R. Rigby, M. H. Aliabadi, Stress intensity factors for cracks at attachment lugs., British Aerospace, Filton, Bristol BS99 7AR, U.K., Wessex Institute of Technology, Ashurst Lodge, Ashurst, Southampton S040 7AA, U.K.
- [6] J. Vogwell and J. M. Minguez , "Failure in lug joints and plates with holes," Engineering Failure Analysis, Vol. 2, Issue 2, 1995, pp129-135.
- [7] Abraham J. , Damodara Reddy, "Design Structural Analysis and Fatigue Calculation of Wing Fuselage Lug Attachment of a Transport Aircraft," International journal & magazine of Engineering, Technology, Management and Research, Vol. 4, Issue 8, August 2017, ISSN: 2348-4845,60-65.
- [8][1] Michael C Y Niu, Airframe stress analysis and sizing, Hong Kong Conmmilit press LTD, 2nd edition, 1999.
- [9][2] R K Bansal, Strength of materials, Laxmi publications, revised 4th edition, 2009.
- [10][3] Richard G. Budynas, J. Keith Nisbett, Shigley Mechanical engineering Design, Mc Graw Hill, 9th edition, 2011.
- [11] Scott D. Henry, et al, Fatigue data book: Light structural alloys, ASM International, 1995, ISBN 0-87170-507-9.
- [12] MSC. Nastran Linear Static Analysis User's Guide, Retrieved from [www.mscsoftware.com](http://www.mscsoftware.com), MSC. Software Corporation, CA, 2012.
- [13] S S Rao, Finite element method in engineering, Elsevier Publications, 4th edition, 2004.
- [14] Nithin S Ghokhale, Sanjay S. Deshpande et al, Practical finite element analysis, Finite to infinite, Pune, India, 1st edition, 2008.
- [15] Robert D Cook, Finite element modeling for stress analysis, John Wiley & Sons, 1st edition, 1995.
- [16] Shashikumar. C, Nagesh. N, Ganesh, "Design and Analysis of Wing fuselage attachment bracket for fighter aircraft," International Journal of Engineering Research And Technology, Vol. 4, Issue 1, January-February 2016, ISSN 2091-2730.
- [17] T L Anderson, Fracture mechanics - fundamentals of application, Taylor &Francis, 4th edition, 2017.
- [18] Sriranga B.k., Kumar R., "Stress Analysis and Fatigue life prediction of wing- fuselage lug joint attachment bracket of a transport aircraft,"

International Journal of Engineering Research And Technology , Vol. 3, Special Issue 03, May 2014.

[19] Madiha Khan, Mohammed Rehman Khan, D. Smitha, "Design and Analysis on Aircraft Wing to Fuselage Lug Attachment," IOSR Journal of Engineering, ISSN (e): 2250-3021, ISSN (p): 2278-8719, 2018, pp 37-42.

[20] Sumanth M H, Ayyappa T, "Comparative analysis of aircraft wing fuselage lug attachment bracket," International Journal of Engineering Research and Technology (IJERT), Vol. 5, Issue 11, July- 2018. pp 2347-4718.