

Design and Implementation of Fuzzy logic based Multilevel Inverter for Micro Grids considering Bidirectional Power Flow through the Interlinking Converters

¹ D. Vyshnavi, ² Dr J. Sreenivasulu, ³Dr. M. Anka Rao

¹PG-Scholar, Department of EEE

^{2,3}Assistant professor, department of EEE

JNTUA COLLEGE OF ENGINEERING, ANANTAPUR, A.P

Abstract:

The research focuses on the bidirectional power flow in ac/dc hybrid microgrid (HMG) using the interlinking converter (IC). The primary difficulty is managing power flows between all sources located on the two types of sub-grids, which is more difficult than earlier attempts created for only ac or dc microgrids. Not much research has been done into this broader spectrum of control. It would require the synchronised operation of dc sources, ac sources, and converters to function properly. The converters might redirect power from an alternating current (ac) to a direct current (dc) sub-microgrid. This converter allows load requirements to be met despite an absence of power in a sub-microgrid comprised of distributed generators (DGs) with droop controllers, which are critical to the system's stability during islanding. In this study, we investigate how the direction of power flow affects the small-signal stability of islanded droop-based HMGs. We begin by developing a linearised state-space model of an HMG. Time-domain simulations in MATLAB/Simulink show that increasing generation on the dc subgrid improves the HMG stability margin overall during islanding.

Keywords: interlinking converter (IC), hybrid microgrid (HMG)

I. INTRODUCTION:

New energy is consumed by microgrids relatively efficiently [1, 2]. More and more research is turning to DC hybrid microgrids [3, 4], which combine the best features of DC and AC microgrids. Converters typically support bus voltages, and the capacity of islanded AC-DC hybrid microgrids is restricted. This means that the converters' interconnections are vital to the reliable operation of AC-DC hybrid microgrids. Recently, the idea of forming a hybrid microgrid by linking isolated ac and dc microgrids via bidirectional ICs has been proposed. [5,6]. A bidirectional interlinking converter (IC) operates in tandem with the ACS and DCS to facilitate power transmission between the two systems in hybrid systems [3]. Power control systems for the management of ACS or DCS are reviewed in [7], and each sub-grid can be run in either grid-connected or islanded mode. Many organisations use decentralised control techniques based on typical droop features. [8]. However, most published power management techniques dealt exclusively with ACS or DCS settings. [9], introduced the idea of a droop controller for ACS. To maintain power sharing in ACSs, a decentralised control technique with an additional droop gain is presented in [10]. Adaptive droop gain using a virtual voltage and frequency frame is provided in [11] to boost the system's efficiency. This technique permits autonomous regulation of power flow.

However, slight variations in ac frequency and voltage output may enhance inter-sub grid circulating currents. Power penetration, control methods, loads, line conditions, etc., are also claimed to affect frequency and voltage [12]. A phase compensation transfer function has been incorporated into the unified power control loop [13] to improve the ac frequency and voltage. [14] presents a droop approach for coordinating power flows and covering adequate power sharing among many sub-grids. The mathematical model of microgrid stability analysis has been the primary focus of work aiming to increase its stability [15]. Maximising droop advantages enhance microgrid reliability. Predictive and computational precision are both impacted by the microgrid model. Microgrid stability analysis needs improvement; however, many studies have been done on proposed methods to trigger DGs' changes in load to make instantaneous adjustments to their output power, allowing them to participate actively in voltage management and microgrid frequency control.

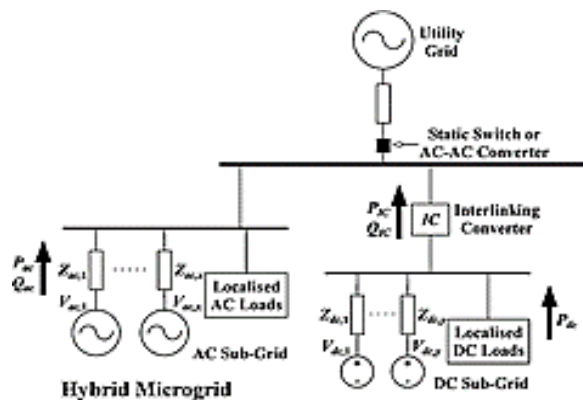

Fig 1: A typical hybrid ac/dc microgrid

Nikos [16] has improved AC/DC hybrid microgrid controller method, which was applied to the model, control, and simulate the microgrid. Employing a linear droop controller such as voltage feedback led to increased microgrid voltage stability in the islanded mode. To account for network dynamics and loads, a small-signal model of the ac and dc subgrids is created [17]. As a further point, the authors of [18] conducted a thorough stability analysis and found that strict management of dc/dc converters in dc subgrids would reduce HMG stability. The effect of droop gains on stability margins was also examined in a work described in [19], which offered a small-signal model of the HMG. Instability may result if the droop constant is more significant, which could cause the dominant modes to move to the right half of the complex plane. Most published works have analysed the effects of droop gains on HMG stability or dealt with the creation of control techniques for the IC. The impact of the two-way flow of power on HMG stability is first examined in this paper. The direction of power flow through the IC can be changed by adjusting the load on the ac and dc subgrids. Through eigenvalue analysis, we examine how the power flow between the ac and dc subgrids affects the HMG's stability margin. To confirm the effect of interconnection coupling (IC) power exchange between subgrids on HMG stability with various topologies, simulations are run in the time domain.

II. SYSTEM STRUCTURE:

Figure 1 depicts a straightforward hybrid ac/dc microgrid. 1. It comprises an ac microgrid with traditional DG sources, a dc microgrid with two dc type sources, and an IC that connects the two microgrids. Individual loads are also included in each of these microgrids. In addition, the ac microgrid connects the hybrid microgrid to the primary utility grid during regular grid operation. In general, microgrids are believed to function in grid-connected or islanding

modes. Power conversion is minimised by similar grouping sources, storages, and loads into smaller, more manageable sub-grids when possible. One or more converters may be used to connect the sub-grids, with the number needed depending on the converter ratings and the sub-grid capacities. However, many converters are used to connect the sub-grids; their primary function is to allow for the bidirectional movement of electricity between the sub-grids in response to changes in supply and demand. Following formation, the hybrid microgrid can be connected to the AC utility mains via an intelligent transfer switch, just as conventional AC microgrids do.

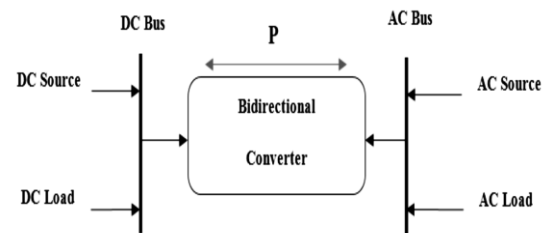

Fig2: The diagram of the AC/DC microgrid structure

The schematic of the microgrid is shown in Figure 2. It consists of two AC sections, one DC section, and an interface converter. When one side of the system's load or generation changes, it might influence the other. Any additional electricity needed to keep everything running smoothly comes from the opposite end of the bus. The DC voltage and AC frequency are stabilised, and the controllers are developed in a decentralised model to create power based on the needs of each component.

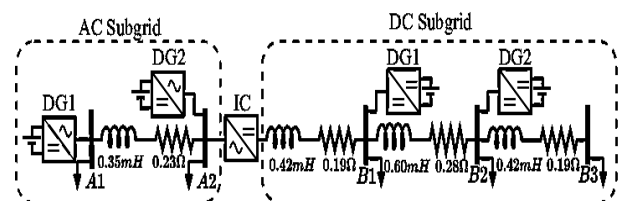

Fig 3: Hybrid microgrid under study.

Fig. 3 shows a simplified schematic representation of a hybrid microgrid (HMG) with ac and dc distributed generators (DGs), ac and dc distributed loads, and an IC. It is possible for a microgrid to function either as a grid-connected or an island system. The central power grid controls voltage and frequency in grid-connected mode. Power sharing across DG units and voltage and frequency regulation are tasks handled by microgrid controllers in the interconnected mode [20]-[22]. Connecting to the microgrid, many DG units use electronic power inverters voltage-sourced converters (VSC) [23], [25]. Improved power quality, voltage regulation, fault current coordination, and reactive

power (VAr) support are the primary benefits of an interface based on power electronics [26]. However, low inertia in inverter-based microgrids makes it harder to keep them stable and dampen oscillations. Both nonlinear and linear methods have been presented for controlling the current or voltage in three-phase VSCs. However, there is no guarantee that nonlinear methods will outperform linear ones, and they add complexity to the system in terms of design and implementation. The two primary categories of linear methods are those that use a stationary reference frame (SRF) and those that use a rotating reference frame (RRF). A large steady-state error is common in SRF-based systems, but RRF-based methods can achieve perfect stability. The most common current and voltage regulators that apply RRF theory are PI-based. PI-based controllers are typically used for zero-level control in inverter-based microgrids. Despite its usefulness, popularity, and ease of tuning, PI control suffers from a slow reaction, a big overshoot, and a lengthy settling period. It's not very sturdy, and the axes aren't decoupled. For microgrids to maximise asset utilisation and prevent violations of operational constraints, voltage, current stability, and transient behaviour must be significantly enhanced. The research uses time-domain simulations of a single DG unit to demonstrate that, compared to PI-based controllers, the FUZZY-based solution provides improved transient performance and is more resistant to uncertainties in system parameters.

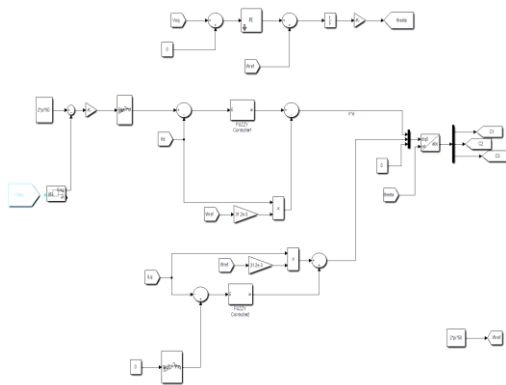

Fig4: Simulink diagram of the proposed system

III. INTERLINKING CONTROL (IC) BETWEEN SUB-GRIDS:

Coordination across sub-grids is necessary for backup purposes regardless of the method used to distribute power equitably within each sub-grid. This must be accomplished before the ac or dc sub-grid sources may be included in the hybrid microgrid's overall power-sharing scheme. The benefits of such a larger scale of power sharing can be summed up as follows.

- Even without a quick communication link between the sources, an overloaded source placed in the hybrid microgrid did not create a single point of failure.
- Regardless of the location where the load transients are triggered, individual source variations are always kept low. Certain sources, like fuel cells, may appreciate smaller modifications; nevertheless, because of their often-delayed responses, these sources should avoid having their parameters changed too much.
- Source capacities can be shared between the two types of sub-grids, hence allowing backup reserve within each sub-grid to be reduced considerably. These advantages cannot be realized by just relying on droop-controlled sources.

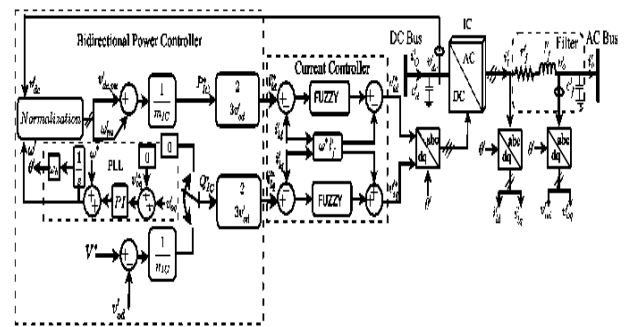
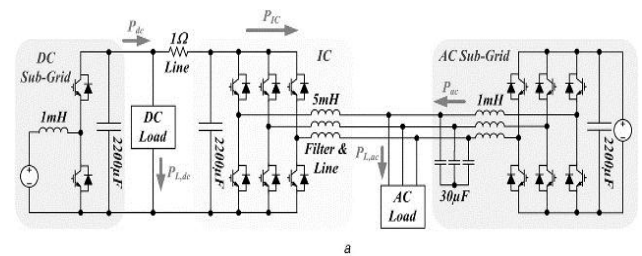
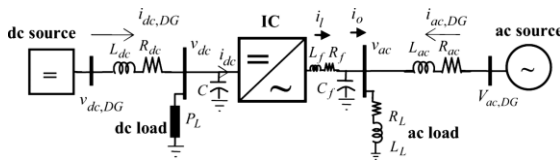

FIG 5: Control structure of the interlinking converter

The interface converter between AC and DC sections should have high rectifier and inverter capabilities. If the output power of the AC side is less than its power consumption, it would be necessary to receive part of the required power through the DC side. In this case, the converter acts as an inverter. Also, if the output power of the DC side is low, it is necessary to receive part of the required power through the AC side. In this case, the converter functions as a rectifier. The converter receives the changes according to DC and AC voltage and frequency and acts accordingly. In the islanding mode of operation, and during light loading of the dc part, the demanded power is shared among the dc sources using the droop characteristics.

3.1 MODELING OF IC IN THE HMG:



The overall structure of the IC is depicted in Fig. 5. This control scheme implements a bidirectional power controller followed by a current controller [28]. The state equations of the IC current controller and the output filter are the same as [9-13] the IC employs a phase-locked loop (PLL) to determine the output ac voltage frequency (ω) and angle (θ) at its ac terminal. The state equation of the PLL is described by

Where θ_p is the integrar term of PLL and where K_{pp} and K_{ip} are the PI gains of the PLL.

$$\theta_p = V_{oq} - V_{oq}^* \dots \dots \dots (1)$$

$$\omega_p = k_{pp}\theta_p + k_{ip}\theta_p + \omega^* \dots \dots \dots (2)$$

Furthermore, the ac frequency (ω) and dc voltage (V_{dc}) are brought to a per-unit range of [-1; 1], through a normalisation process adopted from [9]. The IC is used to transfer power between the ac and dc subgrids. The fuzzy controller can be used instead of a droop controller when only one IC exists where the PI controller is used in the existing system. The IC is primarily concerned with the active power transfer, so the IC reference reactive power (Q^*_{ic}) can be set to zero when the power flows from the dc to ac subgrid. When supporting an ac subgrid with limited reactive power resources, the IC can contribute to reactive power sharing. The stability analysis is mainly directed towards the bidirectional active power flow through the IC.

IV. Fuzzy logic controller:

The fuzzy logic system is a flexible and robust controller that is suitable for all practical applications in every field of technology. It can approximate any nonlinear function to the desired level with high accuracy. Here we are using 49 rules, and the table is given below.

Table 1:

DE/ E	NL	NM	NS	Z	PS	PM	PL
NL	PL	PL	PL	PL	Z	Z	Z
NM	PL	PL	PM	PM	Z	Z	Z
NS	PL	PM	PS	PS	NM	NS	N M
Z	PL	PL	PS	Z	NS	NM	NL

PS	NM	PS	PS	NS	NL	NL	NL
PM	Z	Z	Z	NM	NM	NL	NL
PL	Z	Z	Z	NL	NL	NL	NL

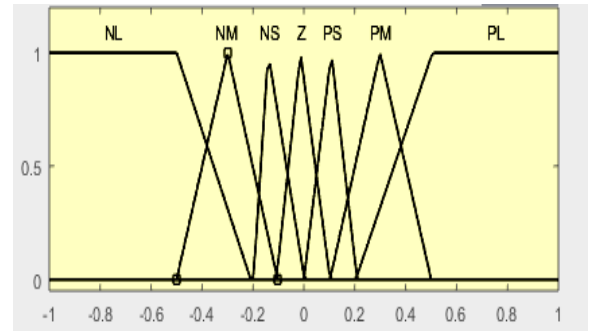

Fig 6 :Input membership function of error signal

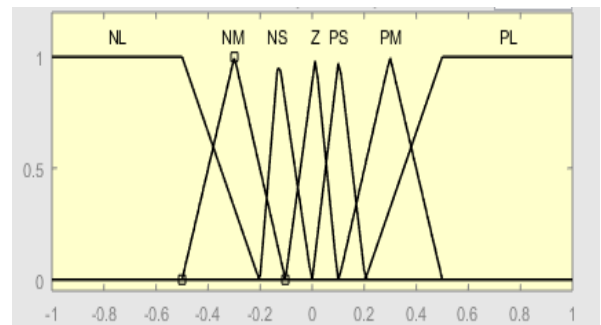

Fig 7: Input membership function of change in error signal

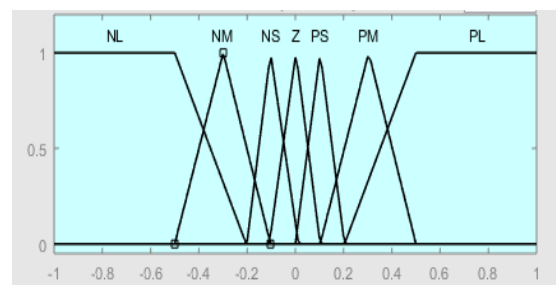
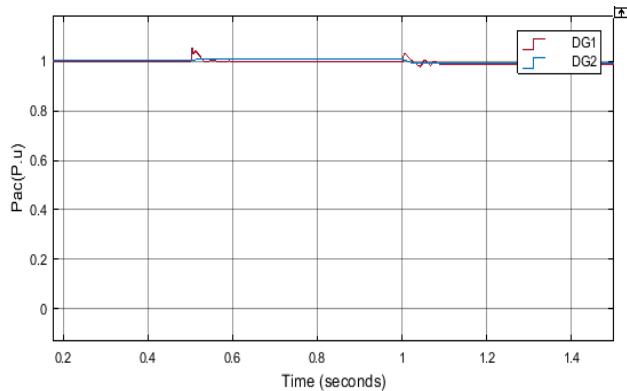
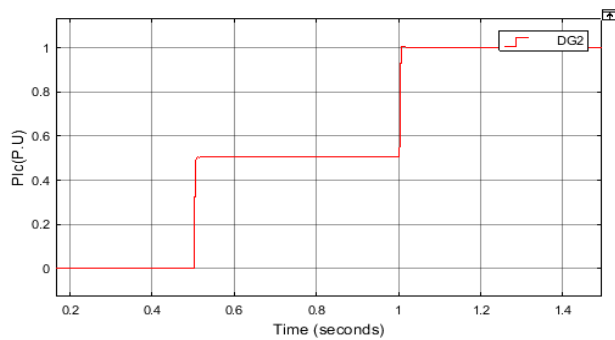

Fig 8 : Output membership function

V.SIMULATION RESULTS:



(a)



(b)

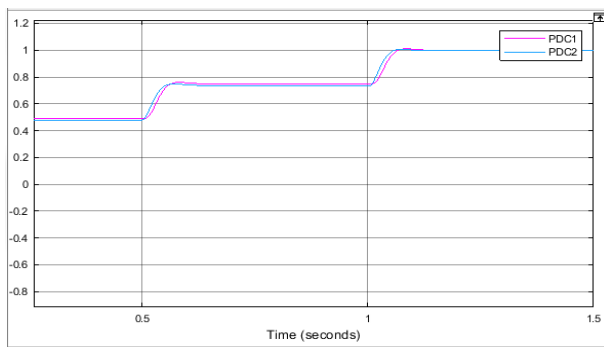

(c)

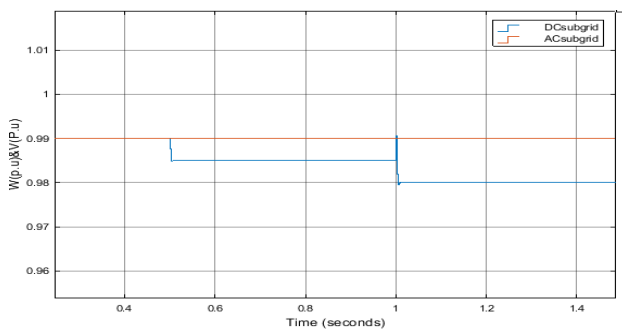

(d)

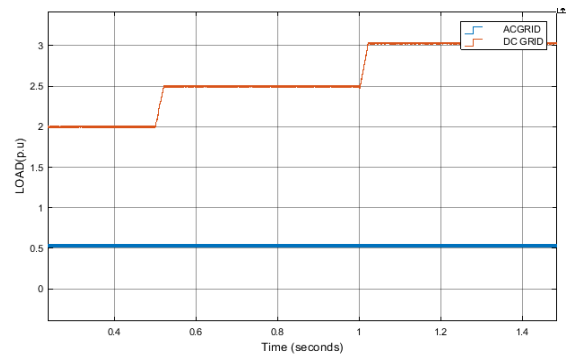

(e)

FIGURE 9. Dynamic responses for dc to ac power flow condition without IC reactive power support.

A total dc power demand of 1 p.u. is applied to the HMG's dc subgrid in Fig. 2. The ac subgrid's ac loads are adjusted so that, from time $t = 0$ to 0.5 s, 2.0 p.u. of ac power is applied. 1) The ac subgrid is loaded with 2.0 p.u. for the duration of time $t = 0$ to 0.5 s. 2) By connecting an additional 0.5 p.u load at Bus-A1, the ac subgrid is overloaded at 2.5 p.u at time $t = 0.5$ s. 3) By adding a second 0.5 p.u load at Bus-A2, the total load on the ac subgrid rises to 3.0 p.u at $t = 1$ s. as shown in 9(e). Additionally, Figs. 9a and 9c show the output power responses of the DGs for the ac and dc subgrids, respectively. Fig. 9b displays the IC's dynamic response to the power flowing through it. Figure 9d shows a plot of the measured dc voltage and ac frequency at the IC terminals. The two DGs in the dc subgrid are found to produce similar amounts of power due to the low dc line resistance. This case study shows that a better dynamic performance may be obtained as the active power flow from the dc to ac subgrid increases.

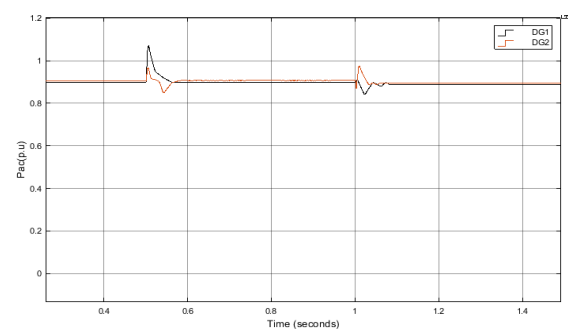

(a)

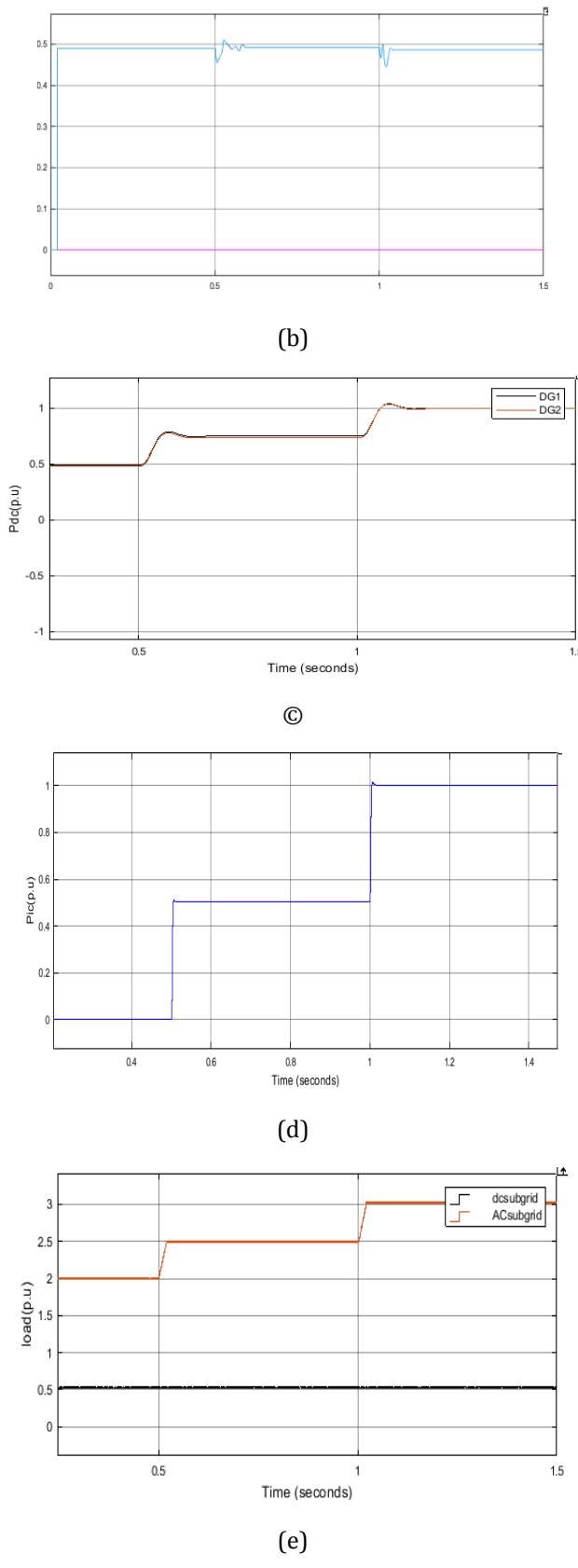

When active power is transferred from the dc to the ac subgrid and the IC is asked to provide reactive power to the ac subgrid, the (QIC-V) droop control loop for the IC is activated. It is found that the IC shares the ac subgrid's need for reactive power in response to an increase in ac load based on its droop characteristics. While the ac subgrid increased its need for power, the IC would continue injecting reactive power as long as its capacity allowed. If the reactive power resources of the ac subgrid are limited, these simulation results confirm to the IC capabilities of the reactive power support. An oscillatory-free dynamic behaviour is maintained using fuzzy controller of the power flow from the dc to the ac subgrid.

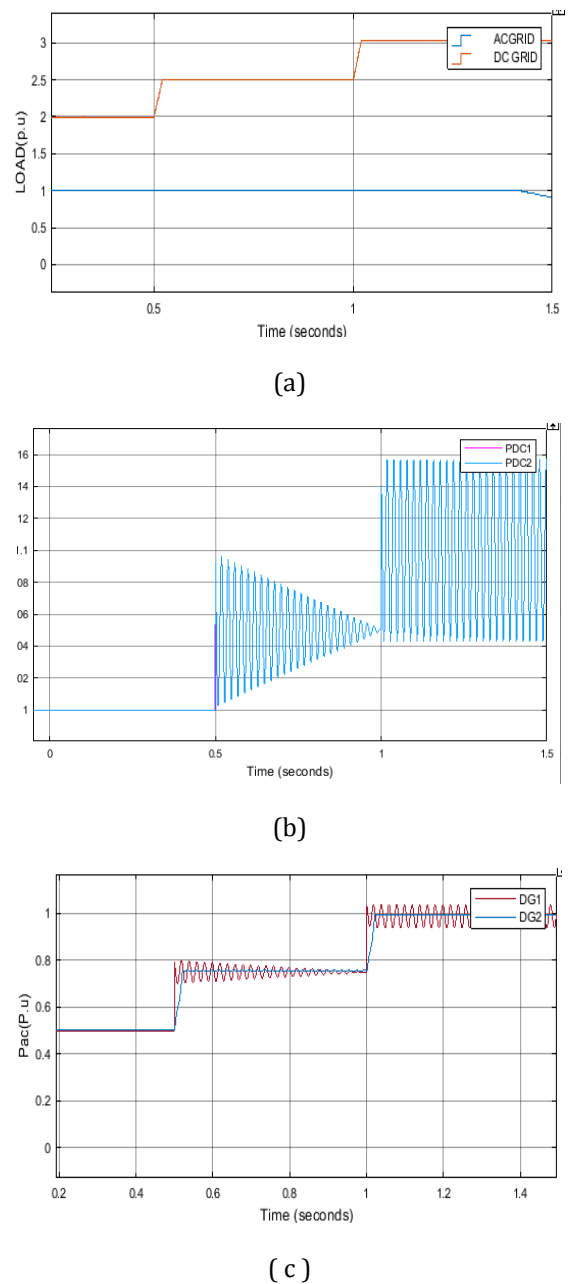

FIGURE 10. Dynamic responses for dc to ac power flow condition with IC reactive power support.

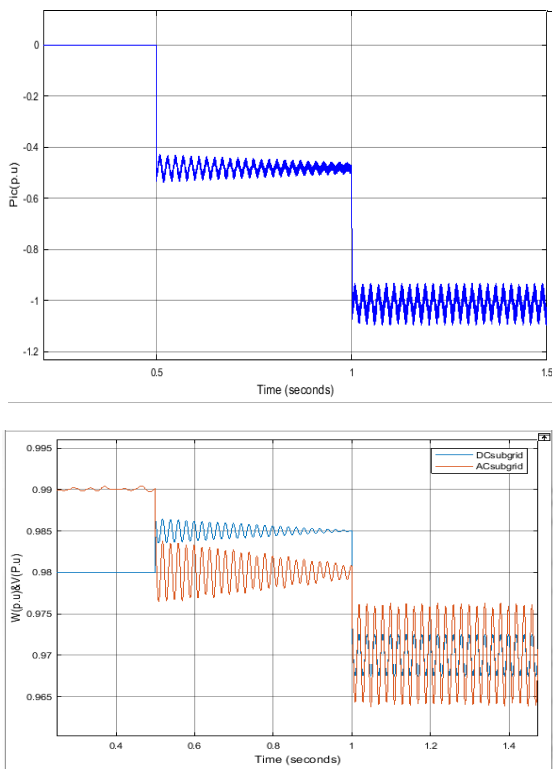
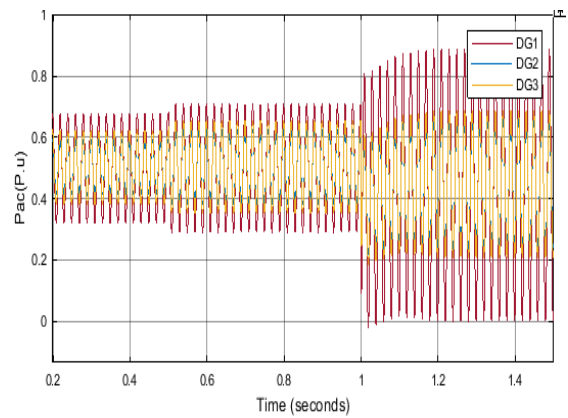
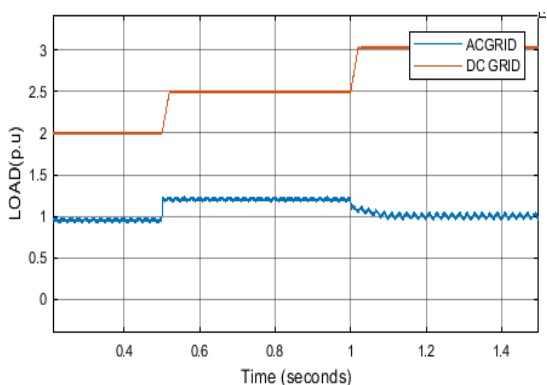
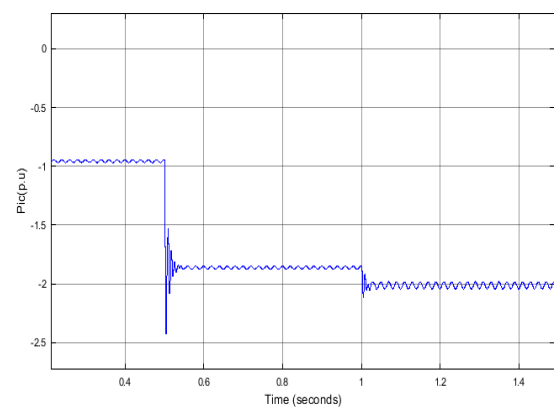

FIGURE 11. Dynamic responses for ac to dc power flow condition.

The effect of power transfer from the AC grid to the DC subgrid is measured and analysed in terms of its effect on HMG reliability. A total of 1.0 p.u of ac power is required to be drawn from the ac subgrid for the entire period, while the dc subgrid is loaded at 2.0 p.u from $t = 0$ to $t = 0.5$ s, 2.5 p.u from $t = 0.5$ to $t = 1$ s, and 3.0 p.u from $t = 1$ to $t = 1.5$ s.



(a)



(b)

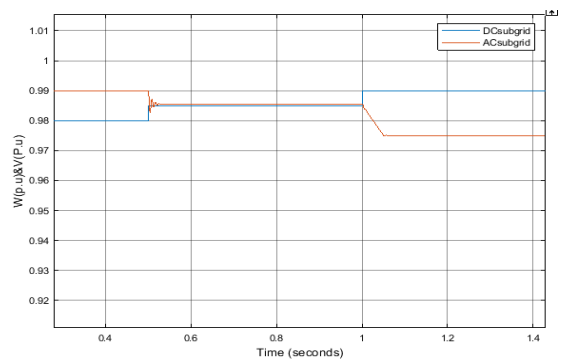

(c)

FIGURE 12. Dynamic responses for an increase in the ac power generation capacity.

The ac subgrid's Bus-A1 is also wired to a 1.0 p.u. generating capacity DG. As an alternative, switching off the DG unit at Bus-B2 reduces the dc subgrid's power-generating capability to 1.0 p.u. This results in an increase of 3.0 p.u. in the ac subgrid's total power generation capacity. As shown in Fig. 11a, the ac and dc subgrids require 1.0 and 2.0 p.u. of power for the time interval $t = 0$ to 0.5 s. In Fig. 11b, the dynamic responses

of the DGs' ac and dc subgrid power outputs are shown, and in Fig. 11c, it is seen that the IC transfers 1.0 p.u from the ac to the dc subgrid at $t = 0$ to 0.5 s to supply the dc load. Figure 11d depicts the alternating current frequency and direct current voltage.

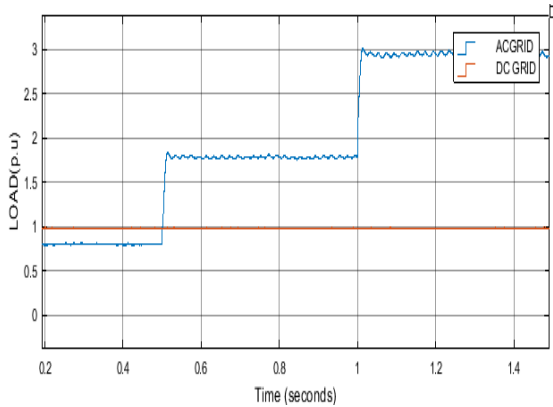

(a)

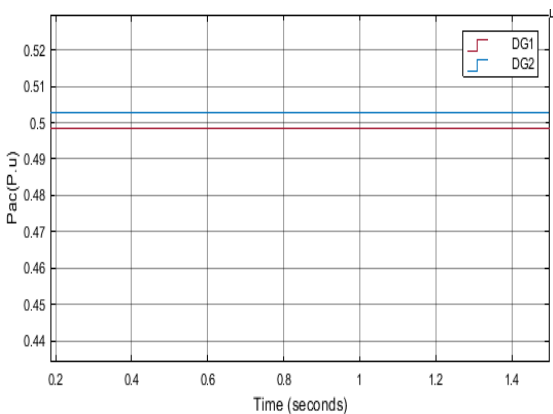

(b)

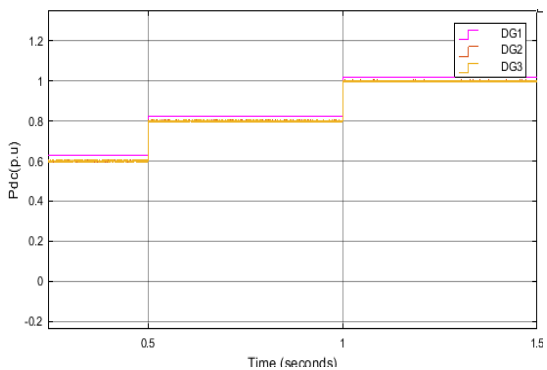

(c)

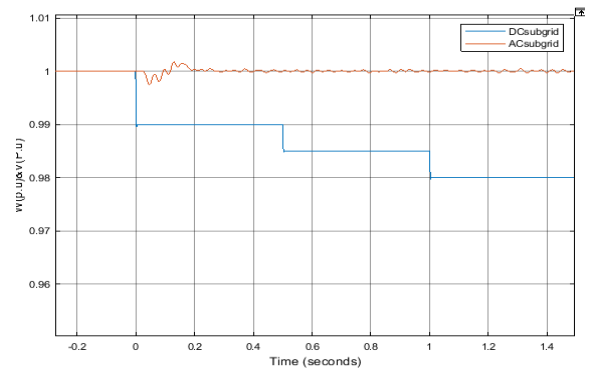

(d)

FIGURE 13. Dynamic responses of an increase in the dc power generation capacity.

When DC generation capacity is increased, the dynamic system response of an ac/dc hybrid microgrid (HMG) is studied. From $t = 0$ to 0.5 s, the ac and dc subgrids' power requirements are 0.8 and 1.8 p.u., respectively, as shown in Fig. 13a. In Fig. 13b and 13c, we see the dynamic response of the DGs' power outputs in both ac and dc subgrids. The extra DG unit clearly aids in the distribution of electricity inside the dc subgrid. As shown in Fig. 13c, the three DGs in the dc subgrid contribute equally to the rise in the dc load at $t = 0.5$ and 1.0 s. Fig. 13e shows that the ac frequency and the dc voltage are stable. Incorporating more DGs into the dc subgrid, as indicated by the results, would maintain the subgrid's current level of dynamic performance.

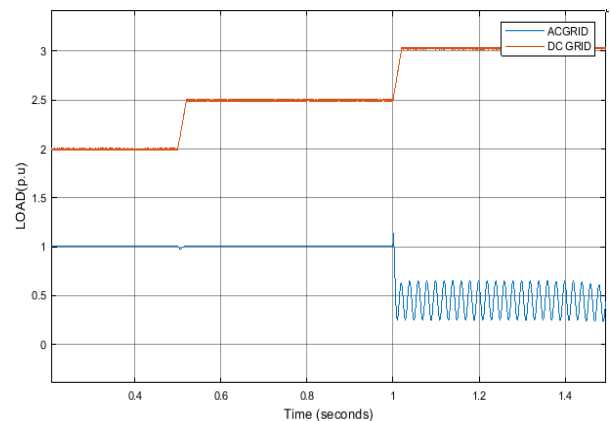

(a)

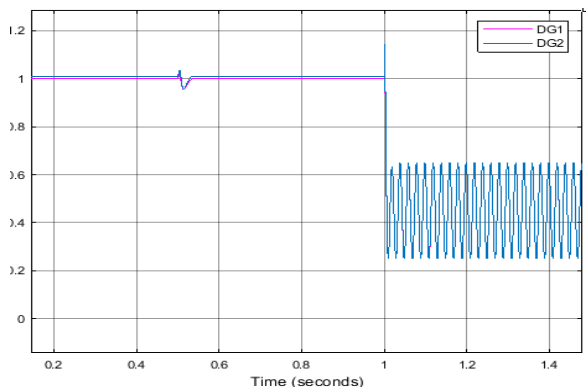

(b)

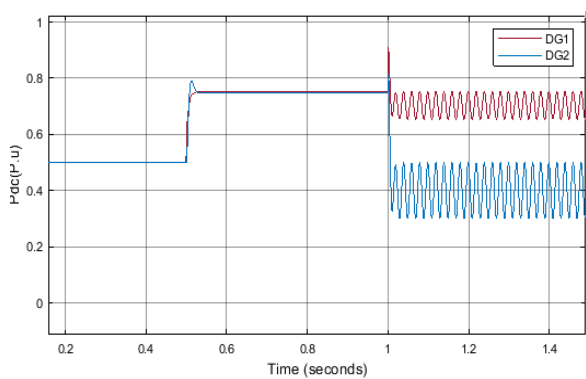

(c)

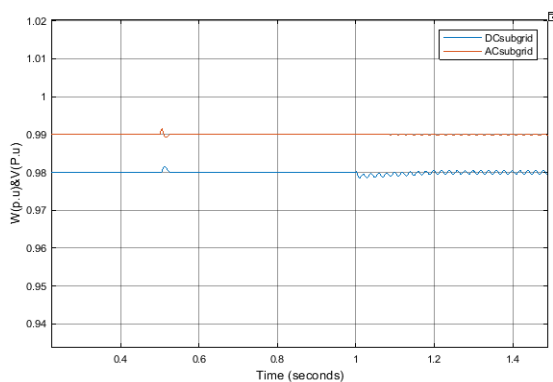

(d)

FIGURE 14. Dynamic responses for ac to dc power flow condition in case of droop control in the ac subgrid.

As can be seen from the simulation results, even when the DGs in the ac subgrid take on distinct droop characteristics, droop-based HMGs will still display an oscillating behaviour for the ac to dc power flow direction. As a result, changing the values of the droop controllers will not fix the system's instability. For this reason, fuzzy control is used in this investigation to dampen the oscillator's behaviour while maintaining its superior performance.

Conclusion:

The impact of the power flow between ac and dc subgrids in an HMG on the stability of the system. It is observed that when the power flow from the ac to dc subgrid increases, the stability margin of the HMG may be reduced. This is because when the power is exchanged from the ac to dc subgrid, the dynamics associated with the ac subgrid have greater influence on the HMG stability as compared to those of the dc subgrid. Additionally, an increase in the generation capacity of the ac subgrid increases the power flow from the ac to dc subgrid to supply the dc load power, which could degrade the stability of the HMG. The simulation results show that droop-based HMGs oscillate in the ac to dc power flow direction even when the DGs in the ac subgrid have separate droop characteristics. Thus, adjusting the droop controller values won't stabilise the system. Fuzzy control dampens the oscillator's behaviour while preserving its exceptional performance in this study.

REFERENCES:

- [1] Ahmed, M., Meegahapola, L., Vahidnia, A., Datta, M.: Stability and control aspects of microgrid architectures-A comprehensive review. *IEEEAccess*. 08(1), 0144730-144766 (2020)
- [2] Adrian Mihai Iuoras, Sorin Ionu Salcu, Calin Gheorghe Rusu, Calin Marginean, Petre Dorel Teodosescu "Power factor compensation for a single-phase AC-DC Hybrid Micro-Grid" 978-1-7281-6990-3, 2020
- [3] Gupta, A., Doolla, S., Chatterjee, K.: Hybrid AC-DC Microgrid: ' Systematic evaluation of control strategies. *IEEE Trans. Smart Grid*. 9(4),3830-3843 (2018)
- [4] Bagherzadeh, M., Karshenas, H.R., Golsorkhi Esfahani, M.S.: Control method for improvement of power quality in single interlinking converter hybrid AC-DC microgrids. *IET Smart Grid*. 4(4), 414-428 (2021)
- [5]. Rasoolzadeh, A., Salmasi, F.R.: Reduced-order dynamic model for droop-controlled inverter/converter-based low-voltage hybrid AC/DC microgrids - part 1: AC sub-microgrid. *IET Smart Grid*. 1(4), 123-133(2018)
- [6] Y. Han, H. Li, P. Shen, E. A. A. Coelho, and J. M. Guerrero, "Review of Active and Reactive Power Sharing Strategies in Hierarchical Controlled Microgrids," *IEEE Trans. Power Electron.*, vol. 32, no. 3, pp. 2427-2451, May 2017. [5] P. Kundur, *Power System Stability and Control*, vol. 23. 2006

- [7] Lv, Z., Zhang, Y., Xia, Y., Wei, W.: Adjustable inertia implemented bidirectional power converter in hybrid AC/DC microgrid. *IET Gener. Transm. Distrib.* 14(17), 3594–3603 (2020)
- [8] M. C. Chandorkar, D. M. Divan, and R. Adapa, "Control of parallel connected inverters in standalone ac supply systems," *IEEE Trans. Ind. Appl.*, vol. 29, no. 1, pp. 136–143, Jan. 1993.
- [9] H. Liang, B. J. Choi, W. Zhuang, and X. Shen, "Stability enhancement of decentralized inverter control through wireless communications in microgrids," *IEEE Trans. Smart Grid*, vol. 4, no. 1, pp. 321–331, Aug. 2013.
- [10] Y. Li and Y. W. Li, "Power management of inverter interfaced autonomous microgrid based on virtual frequency-voltage frame," *IEEE Trans. Smart Grid*, vol. 2, no. 1, pp. 30–40, Mar. 2011.
- [11] J. Zhou, H. Zhang, Q. Sun, D. Ma, and B. Huang, "Event-based distributed active power sharing control for interconnected AC and DC Microgrids," *IEEE Trans. Smart Grid*, pp. 1–1, 2017. [10] A. A. A. Radwan and Y. A.-R. I. Mohamed, "Networked control and power management of AC./DC hybrid microgrids," *IEEE Syst. J.*, pp. 1–12, 2014.
- [12] "IEEE guide for conducting distribution impact studies for distributed resource interconnection," *IEEE Std 1547.7-2013*, pp. 1–137, Feb. 2014.
- [13] X. Li et al., "A unified control for the dc-ac interlinking converters in hybrid AC/DC microgrids," *IEEE Trans. Smart Grid*, pp. 1–1, 2017.
- [14] N. Eghtedarpour and E. Farjah, "Power control and management in a hybrid AC/DC microgrid," *IEEE Trans. Smart Grid*, vol. 5, no. 3, pp. 1494–1505, May 2014
- [15] Malik, S.M., Ai, X., Sun, Y., Zhengqi, C., Shupeng, Z.J.I.G., Transmission and Distribution, "Voltage and frequency control strategies of hybrid ac/dc microgrid: A review", *IET Generation, Transmission & Distribution*, Vol. 11, No. 2, (2017), 303-313, doi: 10.1049/iet-gtd.2016.0791.
- [16] Hatziargyriou, N., "Microgrids: Architectures and control, John Wiley & Sons, (2014).
- [17] A. A. Radwan and Y. A.-R. I. Mohamed, "Networked control and power management of AC/DC hybrid microgrids," *IEEE Syst. J.*, vol. 11, no. 3, pp. 1662-1673, Sep. 2014.
- [18] A. A. A. Radwan and Y. A.-R.-I. Mohamed, "Assessment and mitigation of interaction dynamics in hybrid AC/DC distribution generation systems," *IEEE Trans. Smart Grid*, vol. 3, no. 3, pp. 1382-1393, Sep. 2012.
- [19] D. K. Dheer, S. Doolla, and A. K. Rathore, "Small signal modeling and stability analysis of a droop based hybrid AC/DC microgrid," in *Proc. 42nd Annu. Conf. IEEE Ind. Electron. Soc. (IECON)*, Oct. 2016, pp. 3775-3780.
- [20] S. Leitner, M. Yazdani, A. Mehrizi-Sani, and A. Muetze, "Small-signal stability analysis of an inverter-based microgrid with internal model-based controllers," *IEEE Trans. Smart Grid*, vol. 9, no. 5, pp. 5393-5402, Sep. 2018.
- [21] N. Pogaku, M. Prodanovic, and T. C. Green, "Modeling, analysis and testing of autonomous operation of an inverter-based microgrid," *IEEE Trans. Power Electron.*, vol. 22, no. 2, pp. 613–625, Mar. 2007.
- [22] A. Bidram and A. Davoudi, "Hierarchical structure of microgrids control system," *IEEE Trans. Smart Grid*, vol. 3, no. 4, pp. 1963–1976, Dec. 2012.
- [23] J. A. P. Lopes, C. L. Moreira, and A. G. Madureira, "Defining control strategies for microgrids islanded operation," *IEEE Trans. Power Syst.*, vol. 21, no. 2, pp. 916–924, May 2006.
- [24] R. Majumder, B. Chaudhuri, A. Ghosh, R. Majumder, G. Ledwich, and F. Zare, "Improvement of stability and load sharing in an autonomous microgrid using supplementary droop control loop," *IEEE Trans. Power Syst.*, vol. 25, no. 2, pp. 796–808, May 2010.
- [25] Y. Li, D. M. Vilathgamuwa, and P. C. Loh, "Design, analysis, and realtime testing of a controller for multibus microgrid system," *IEEE Trans. Power Electron.*, vol. 19, no. 5, pp. 1195–1204, Sep. 2004.
- [26] C. K. Sao and P. W. Lehn, "Control and power management of converter fed microgrids," *IEEE Trans. Power Syst.*, vol. 23, no. 3, pp. 1088–1098, Aug. 2008.
- [27] B. Kroposki, C. Pink, R. DeBlasio, H. Thomas, M. Simes, and P. K. Sen, "Benefits of power electronic interfaces for distributed energy systems," *IEEE Trans. Energy Convers.*, vol. 25, no. 3, pp. 901–908, Sep. 2010
- [28] P. C. Loh, D. Li, Y. K. Chai, and F. Blaabjerg, "Autonomous operation of hybrid microgrid with AC and DC subgrids," *IEEE Trans. Power Electron.*, vol. 28, no. 5, pp. 2214–2223, May 2013.