

The Simulation and Economic Analysis of Palm Oil Empty Fruit Bunches Gasification as Renewable Energy

Muhammad Farizan Praevia¹, Widayat², Endang Kusdiyantini³

¹Magister Energi, Universitas Diponegoro, Semarang, Indonesia

²Departemen Teknik Kimia, Fakultas Teknik, Universitas Diponegoro, Semarang, Indonesia

³Departemen Biologi, Fakultas Sains dan Matematika, Universitas Diponegoro, Semarang, Indonesia

Abstract - Riau Province, the highest palm oil production in Indonesia has 10,270,149 tonnes of plantation, in 2.895 million hectares area. Empty fruit bunches (EFB) are one of the by-products of palm oil plantations and refineries that are not utilized. EFB waste impacts on increasing carbon emissions. The Empty fruit Bunches can be utilized as a new renewable energy source with gasification technology. Gasification is a thermochemical process by which carbon in fuel is converted into a combustible gas, known as syn-gas. Modeling of gasification fueled by shredded empty fruit bunches can produce an electricity capacity of 152 MW. The operation parameters by simulation using Aspen Plus software, consist of gasification temperature: 800 °C; Equivalent Ratio (ER): 0.2; and moisture content: 30% producing syn-gas with a calorific value of 21.87 MJ/kg. The syn-gas consists of H₂ 25.78%; CH₄ 8.31%; CO 20.25%; CO₂ 21.62%; H₂O 16.47%. By the feasibility analysis, the investment cost of the power plant is IDR 2,750,015,292,173, with an interest rate of 15%, the investment cost can be returned in 3 years with IRR value of 47.68%.

Key Words: empty fruit bunches, gasification, syn-gas, biomass power plant

1. INTRODUCTION

Indonesia's commitment contributes to global climate change declared in Paris Agreement, with a target to reduce greenhouse gas emissions by 29% in 2030. This target has been outlined in the National Energy General Plan by increasing the energy mix of New and Renewable Energy by 23 % in 2025 [1]. One of the solutions to increase the percentage of renewable energy is by using biomass gasification. Gasification is a thermochemical process which carbon fuel is converted into a combustible gas, known as syn-gas (synthesis gas).

Syn-gas can be used directly as gas turbine fuel or as a raw material for chemical industries. Syn-gas fuel consists of hydrogen (H₂), carbon monoxide (CO), methane (CH₄), carbon dioxide (CO₂), water vapor (H₂O), nitrogen (N₂), tar, ammonia (NH₃), hydrogen sulphide (H₂S) and hydrogen chloride (HCl). This process occurs when several oxidants consisting of pure oxygen, air, and steam are reacted at high temperatures with carbon and fuel in the gasifier [2]. The

stages of the gasification process can be divided into: (1) drying stage (at 100-200 °C), (2) pyrolysis stage (at 200-500 °C), (3) gasification and combustion stages (at 500-1000 °C). Gasification aims to convert liquid and solid fuels into flammable gas using a reactor called a gasifier. A gasification system consists of a gasification reactor equipped with fuel pre-treatment and gas conditioning [3].

This research uses Riau Province, Sumatera, Indonesia as an object. Based on data from 2019-2021, issued by the Ministry of Agriculture of the Republic of Indonesia, Riau is the province with the highest level of palm oil production, reaching 10,270,149 tonnes palm oil which is planted on 2.895 million hectares of land. Empty Fruit Bunches (EFB) are the largest solid waste from plantations and palm oil refineries that are currently not utilized. Compare with the palm shell, it can be directly burnt an biomass boiler, but Empty Fruit Bunches are still not being used massively. EFB identify to be used as fuel because it has consisted of calorific value by 17.02 MJ/kg [4].

Gasification technology can be used as an option for utilizing EFB in Riau Province. The biomass gasification process can be modelled with Aspen Plus software. Modelling is needed to get optimal operating conditions of gasification. The optimal condition is when the gas produces fewer impurities and increase efficiency in the process. The main operating conditions studied in this research such as: gasification temperature, biomass moisture, and Equivalent Ratio (ER). Furthermore, the syn-gas which is the product of gasification is reviewed in terms of the net energy value (MW) produced. Energy value is then analysed for the economic feasibility of establishing a biomass power plant in Riau Province and the potential calculation for reducing CO₂ emissions.

2. RESEARCH METHOD

2.1. Empty Fruit Brunches Analysis

Solid fuel quality is measured using three types of analysis; heating value, proximate analysis, and ultimate analysis. The EFB quality [4] showed on Table 1. Data of EFB used that have been chopped with a shredder machine with a size of 10-25 cm. The quality will be used for simulation.

Table -1: Empty Fruit Bunches Analysis

Parameter		Unit	Measurement
			DB
Proximate Analysis	Moisture	% db	31,2
	Ash Content	% db	5,90
	Volatile Matter	% db	78,70
	Fixed Carbon	% db	15,30
Total Sulphur		% db	0,22
Higher Heating Value (HHV)		MJ/kg	18,60
Ultimate Analysis	C	%	41,81
	H	%	5,73
	N	%	0,84
	O	%	45,71

2.2. Gasification Modelling using Aspen Plus

The software used for modelling is Aspen Plus V.10, a product from Aspen Tech. Research was carried out in several stages, starting with the pre-research, conducting literature studies related to biomass and gasification, and the simulation stage by modeling using the Aspen Plus program to get optimum syn-gas conversion. The optimum value is the value of the syn-gas composition with the highest theoretical HHV value (MJ.kg-1) using empirical equations.

Gasification temperature is one of the most influential factors in gasification process. At temperature above 750-800 °C, the endothermic reaction of the H₂ (steam reforming and water-gas reactions) produce H₂ production and the reduction of CH₄ content with increasing temperature [2]. While Equivalent Ratio is related to air flow which affects gasification products. Air supplies, O₂ for combustion (in the case of a fluidized bed) will be affected to the residence time. By the variation of O₂ supply, the air flow rate controls the degree of combustion which, in turn, affects the gasification temperature [5]. Biomass moisture related to the amount of water contained in the biomass material that is feed into the gasifier. The higher the moisture content, the greater the air requirement used to dry the biomass. The variations used in this study consisted of: Gasifier temperature varied from 600-800 °C [2], Equivalent Ratio (ER) 0.15 - 0.30 kg/kg [6], and moisture 20-40 % (data taken ± 10% from laboratory results).

Biomass gasification model used the sub dryer and gasification models described on KG Engineering Solutions research and some literature from modeling conducted by

Rusydy [7]. Gasification process used consists of the decomposition of empty fruit bunches, combustion of volatile matters, char gasification, and gas-solid separation. The producer gas coming out of the gasifier is cleaned of solids contained in the feed and those formed during the gasification process using a separator. In this modeling, air is used as a gasifier agent to show the most optimum conditions.

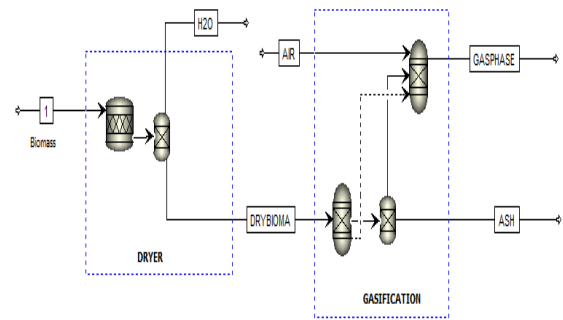

Chart -1: Process Flow Diagram on Aspen Plus

2.3. Techno-Economic Analysis

After obtaining optimal conditions with the highest yield of syn-gas, techno-economic calculations were carried out. The calculation is expected to get a power plant model. Calculation of generated power capacity needs to know the efficiency of the power plant technology used [8]. Techno-economic analysis starts with determine the gasification technology: to be able to calculate the investment cost. Capital budgeting analysis can be used to assess whether a project is acceptable or not. The main analysis was carried out on the net present value (NPV), internal rate of return (IRR), and payback period (PBP). Calculation of NPV, IRR, and PBP using equations (1), (2), (3).

$$PV = \sum_{t=n}^N \frac{CFT}{(1+i)^t} - CF_0 \quad (1)$$

CF₀ : fixed capital cost, CFT : cash in flow, i : interest rate. If NPV > 0, higher return rate.

$$0 = \sum_{t=0}^t \frac{X_t}{(1+IRR)^t} \quad (2)$$

X_t : Cash flow on year-t, IRR: . Rate of Return. If IRR > CF₀, project accepted.

$$PBP = \frac{\text{Initial Investment Cost}}{\text{Annual Cost in flow}} \quad (3)$$

The higher PBP accepted, the project will be executed.

3. RESULT AND DISCUSSION

3.1. EFB Gasification Simulation

Equivalent Ratio (ER) is the ratio between the actual airflow required for biomass combustion. Air flow rate will control the degree of combustion, this will affect to the gasification temperature setting. In this study, the ER variation was 0.15-0.30 at a temperature of 800 °C and 30% moisture. Chart-2 shows the CO₂ concentration in the syn-gas product is directly proportional to the Equivalent Ratio (ER), the higher the ER (0.35), the higher the CO₂ concentration. The ER value indicates the more carbon combustion process, because it produces more CO₂ and this causes a decrease in CO concentration. While H₂ deficiency is caused by the water gas shift reaction which affects the decrease in H₂ concentration. The highest H₂ value is at the ER value of 0.15 of 21.57%. Equivalent Ratio (ER) significantly affects the syn-gas composition. The addition of O₂ will caused more oxidation heat, so that when more gas goes to pyrolysis at the mouth of the gasifier, the pyrolysis temperature will rise [9].

Gasification is an endothermic reaction, the conversion of gas composition is strongly influenced by the temperature change value. Based on the simulation results with constant ER and moisture values, it was found that the concentration of H₂ was increasing, achieving the highest conversion at 800 °C of 25.78% (Chart-3). CO concentration decreased (20.29-20.25 %) although not significantly in the temperature range (600-800 °C). The concentration of CO₂ decreases (21.62%) with increasing temperature (600-800 °C) because higher temperature is good for endothermic reactions forming CO from CO₂ (Boudouard reaction).

The increasing of moisture in empty bunches will cause the gasification temperature decrease. This condition occurs due to the reduction of heat for endothermic gasification reactions. The heat uses for evaporate water in raw materials [7]. Gasification process itself should be maintained at a temperature above 600 °C. The simulation results at variations in moisture content of 20, 30, 40% show the highest H₂ conversion rate at 20% moisture with 21.71% H₂ (Chart-4).

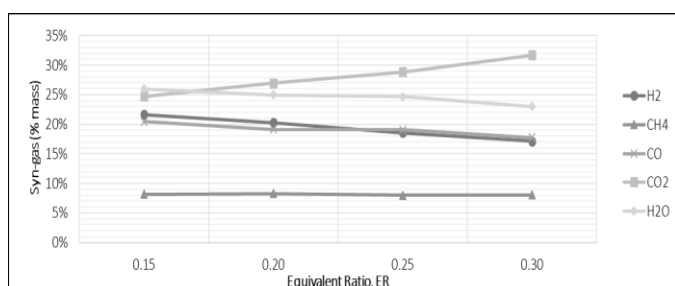

Chart -2: Syn-gas production on Equivalent Ratio (a). 0.20 ; (b). 0.25 ; (c). 0.30 ; (d). 0.35

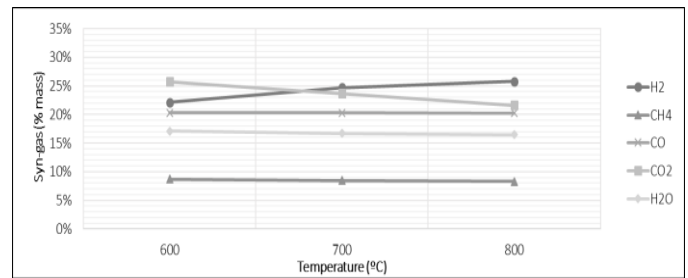

Chart -3: Syn-gas production on Temperature (a).600 °C ; (b). 700 °C; (c). 800 °C

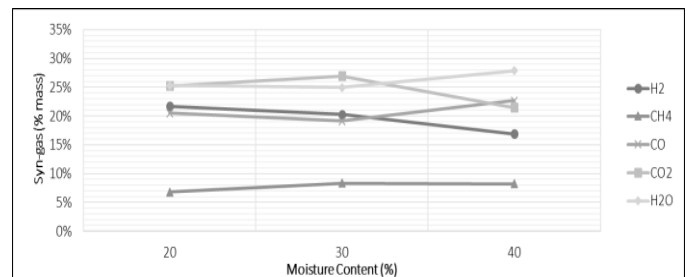

Chart -4: Syn-gas production on Moisture (a). 20% ; (b). 30% ; (c). 40%

3.2. Techno-Economic Analysis

An optimum syn-gas composition was obtained at an average HHV of 20.53 MJ.kg⁻¹ (calculated from syn-gas yield with empirical equation). The operating gasifation parameters with ER = 0.2, gasification temperature = 800 °C, and moisture = 30%. The resulting of HHV or calorific value is used to calculate the generated power capacity. In this study, gasification efficiency on 75.15% [8].

The electrical energy generated from the generator is calculated by the heat rate (HR). Heat Rate is obtained on the basis of empty fruit bunch 480 tons per day. Heat rate value generated by the gasification is assumed to be the generated electric power, which is referred to as the Gross Power on 152 MW. With the reduction of internal power needed for generation by 25%, the rest 75% will sell to the national power plant unit. Details of the cost of investment and operational cost of Biomass Power Plant with gasification technology capacity of 152 MW are shown in Table-2 and Table-3.

Table -2: Fixed Capital Cost Biomass Power Plant 152 MW

Item	Price (USD)
Gasifier	54,568,800
Gas Engine System	29,283,840
Purchased Equipment Cost (PEC)	83,852,640
Transportation(5% PEC)	4,192,632
Piping (21 % PEC)	17,609,054

Installation (11% PEC)	9,223,790
Electrical Cost (15% PEC)	12,577,896
Building Service and Land Cost	1,129
Physical Plant Cost (PPC)	127,457,142
EPC (20% PPC)	25,491,428
Direct Plant Cost (DPC)	152,948,570
Contractor Fee (4% DPC)	6,117,943
Contingency (12% DPC)	18,353,828
Total Fixed Capital Cost	177,420,341
1 USD = 15.550 IDR	IDR 2,750,015,292,173

Table -3: Operating Cost Biomass Power Plant 152 MW

Operating Cost	IDR/year
Chopped EFB (IDR 300.0000/ton, capacity 480 ton/day)	47,520,000,000
Labor Cost	15,000,000,000
Maintenance (2% FC)	55,000,305,843
Manufacturing Cost (MC)	117,520,305,843
Admistration (2% MC)	2,350,406,117
Sales (3% MC)	3,525,609,175
Research (5% MC)	5,876,015,292
General Expense (GE)	11,752,030,584
Total Operating Cost = MC + GE	129,272,336,428

Economic analysis is oriented to the amount of profit so that it attracts investors in investing. The assumptions used in the calculations are as follows:

1. Installed Capacity: 152 MW
2. Bank Loan Interest Rate: 15%
3. Capacity Factor: 80%
4. Book Life of Investment (n): 15 years
5. Construction time: 1 year
6. Raw Materials: EFB
7. Investment Cost: IDR 2,750,015,292,173

The amount of income per year/Cash in Flow (CIF) can be calculated from the kWh output multiplied by the selling price of electricity to PT PLN (Persero) (Indonesian government-owned corporation which has a monopoly on electric power distribution in Indonesia). Based on Minister

of Energy and Mineral Resources regulation, for power plant with capacity >50 MW, the selling price of electricity to PLN: 10.80 cents USD.kWh-1, so the selling price to PLN: 1925.10 Rp.kWh-1. With total electricity sale is 75% of the capacity, an annual income of IDR 1,260,502,319,379 is obtained. While the total investment cost IDR 2,750,015,292,173 and O&M cost per year IDR 129,272,336,428.

Net Present Value (NPV) is calculated by minus the project initial investment (Cfo) from the present value of cash in flow (Cft) on interest rate (i). NPV in the first year is (-) means the investment is not feasible. The NPV is calculated by using equation (1) describe on Chart-5. In trend, the NPV shows (+) in 4th year. So that the Biomass Power Plant is feasible to be established.

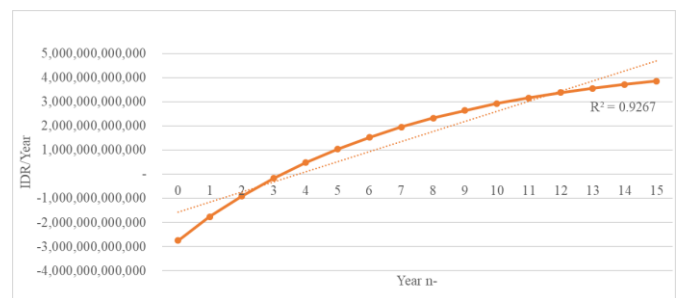

Chart -5: NPV Analysis

The Internal Rate Return (IRR) is calculated using equation (2).

$$NPV = -2,750,015,292,173 - \frac{129,272,336,428}{(1+i)^n} + \frac{1,260,502,319,379}{(1+i)^n}$$

$$0 = -2,750,015,292,173 - \frac{1,131,229,982,951}{(1+i)^{15}}$$

$$(1 + i\%)^{15} = 2.431$$

With using Compound Interest Factor table determined i = 47,58%. So IRR value = 47,58% > 15%, investment is feasible.

While the result of Pay Back Period describes on Table-4. With the selling price energy 1925.10 IDR.kWh⁻¹ PBP achieves on 3 years.

Table -4: Pay Back Period Result

Year-	Costs Spending *)	Income*)	Diff*)
1	2,879.3	1,260.5	-1,618.8
2	3,008.6	2,521.0	-487.6
3	3,137.8	3,781.5	643.7
4	3,267.1	5,042.0	1,774.9
5	3,396.4	6,302.5	2,906.1

*) Billion IDR

4. CONCLUSION

The concept of Waste to Energy, by Empty Fruit Bunches can be utilized for generating electricity with capacity 152 MW using the gasification method. The Aspen Plus software succeeds showing the most optimal condition for the gasification process of empty palm fruit bunches with the main operating parameters measured: (a) Gasification temperature = 800 °C, (b) Equivalent Ratio = 0.2, (c) Moisture = 30%. Those parameters will produce synthetic gas with a heating value, HHV of 21.87 MJ/kg. The syn-gas produced consists of 25.78% H₂, 8.31% CH₄, 20.25% CO, 21.62% CO₂, 16.47% H₂O. The techno-economic analysis shows that with the investment cost of IDR 2,750,015,292,173 at interest rate of 15%, the investment can be returned in 3 years so that the investment is feasible to be established with an IRR value of 47.68%.

REFERENCES

- [1] Indonesia Energy Outlook (2020). Dewan Energy Nasional.
- [2] Doherty, W., Reynold, A., Kennedy D. (2013). "Aspen Plus Simulation of Biomass Gasification in a Steam Blown Dual Fluidised Bed, Materials and processes for energy: communicating current research and technological developments", A. Méndez-Vilas(Ed.), Formatex Research Centre.
- [3] Waliul, MD. (2020). "Effect of different gasifying agents (steam, H₂O₂, oxygen, CO₂, and air) on gasification parameters", International Journal of Hydrogen Energy 45(2020) pp 31760- 3 1774. <https://doi.org/10.1016/j.ijhydene.2020.09.002>
- [4] Novianti, S., M. Biddinika, P. Prawisudha and K. Yoshikawa. (2014). "Upgrading of Palm Oil Empty Fruit Bunch Employing Hydrothermal Treatment in Lab-scale and Pilot Scale", Procedia Environmental Sciences 20 (2014), pp 46 – 54.
- [5] Panda, C. (2012). "Aspen Plus Simulation and Exsperimantal Studies on Biomass Gassification. National Institute of Technology", Rourkela.
- [6] Motta, I.L, Marchesan, A.N, Filho R., Maciel, MR.W. (2022). "Correlating biomass properties, gasification performance, and syngasapplications of Brazilian feedstocks via simulation and multivariate analysis", Industrial Crops & Products 181 (2022) 114808 .<https://doi.org/10.1016/j.indcrop.2022.114808>
- [7] Rusydy. (2017). "Simulasi Gasifikasi Sludge Limbah Industri Pulp Dan Kertas Sebagai Alternatif Energi Baru Terbarukan", Teknik Kimia Universitas Riau.
- [8] Azmi, Muhyiddin. (2014). "Analisis Teknik dan Ekonomi Pemanfaatan Biomassa Sebagai Pembangkit Energi Listrik di Surabaya", Teknik Fisika ITS, Surabaya.
- [9] Mehrdokht B.N., Nader M. (2008). "Simulation of biomass gasification In fluidized bed reactor using ASPENPLUS", Elsevier, Biomass And Bioenergy 32, 245–254.