

# Mobile Application Based Slot Determination In A Parking Lot

Tias Ghosh<sup>1</sup>, Arijit Das<sup>2</sup>, Rimi Majumder<sup>3</sup>, Amisha Rajak<sup>4</sup>, Soma Boral<sup>5</sup>

<sup>1, 2, 3, 4</sup> Under-graduate Student, Dept. of Electronics and Communication Engineering, Guru Nanak Institute of Technology, Kolkata, India

<sup>5</sup> Assistant Professor, Dept. of Electronics and Communication Engineering, Guru Nanak Institute of Technology, Kolkata, India

\*\*\*

**Abstract** - The usage of automobiles, whether public or private, is expanding at an exponential rate in the modern era. The issue of automobile parking arises here. In the case of countries such as India, where infrastructure is expanding at a rapid pace. Thus, effective automotive traffic and parking management systems are required to support the establishment of smart cities. Therefore, the purpose of this project is to provide a realistic way for identifying available spots as well as a smart parking system. This smart system keeps track of the number of vacant parking slots and guides vehicle drivers to quickly reach the closest vacant slot and efficiently using visual cues without having to spend any extra time looking. This system also decides whether or not to allow consumers entry based on the availability of parking spaces. Thus, this parking system facilitates hassle-free automobile mobility across the city while also reducing traffic congestion caused by parking-related searches.

**Key Words:** IR Sensor, Servomotor, Mobile Application, Arduino Uno, WIFI module.

## 1. INTRODUCTION

The increased number of automobiles on streets around the world is a reflection of the world's rapid economic expansion. It's expected that by 2040, there will be 1.6 billion cars worldwide, up from 841 million today. These days, there is a severe lack of adequate parking for vehicles in many public locations, including malls, airports, hospitals, markets, and stadiums. Governments want to strengthen the foundations and frameworks of their current transportation systems. Finding open parking spaces is a common problem in most modern urban neighborhoods, especially during busy periods of various events. To ease this problem the drivers now can check vacant parking spaces by using their mobiles with the help of our system.

A smart car parking system gives a visual output on a mobile phone by using a mobile application and indicating available free parking slots. Every parking space in a smart parking system has its own IR sensor. In consequence, when a car is parked in one slot, the IR sensor in that slot detects the vehicle, turns on the LED, and generates a visual output of a geometrical shape for the mobile application where the LED turns off when the slot is empty. In this way, drivers understand whether the slot is available or not. Thus, a

smart car parking system aids in locating available parking spaces.

## 2. OBJECTIVE

In countries like India, where infrastructure of cities are developing at a rapid pace and the vehicles used by the citizens are increasing day by day, needs smooth traffic mobility. Drivers face problem to find the parking space. As a result, they park their car on the roadsides of city, which leads to traffic congestion. So, this application based smart parking system will provide those drivers an optimized solution and will reduce the traffic jam. Thus, it will help to improve the traffic movement of the city.

## 3. LITERATURE SURVEY

Aashish Joshi et al in 2020 [1] in his paper depicted a smart parking system which is being designed using IR sensors, red and yellow LEDs. If a car is present on a parking slot, then red led will glow up and if it is empty, then yellow led will glow up. This will help the drivers to determine empty slots in a parking lot.

Brundaban Mishra et al [2] created a smart parking system in which a user may pre-book their parking spot or, if necessary, monitor the availability via a website. When a person registers for a parking space for a certain time period, he or she is given an OTP. The driver needs to provide this OTP to access the parking slot. A 7-segment LCD monitor in the parking lot displays the current spot availability. If a parking space is available, the driver may park their vehicle; otherwise, they will be denied admission if no parking space is available.

Smita Awagan et al suggested a mathematical model in 2020 [3] in which a driver can reserve a parking place ahead of time and make an advance payment. Real-time space allocation will be accomplished by the use of dynamic resources, comparable to skill-based routing in a call centre. Before arriving at the venue, the driver will be informed of the best parking locations.

In our paper, we have designed an application based smart parking system using IR sensors, servo motors, Arduino UNO and ESP8266 NodeMCU all in one system. It is low cost and efficient to use in a simple manner.

#### 4. GENERAL COMPONENTS

Arduino Uno- An open-source microcontroller board called the ATmega328P on-board embedded processor helps to perform all the tasks of Arduino UNO. For connecting peripherals, it is being provided input option like, 6 analog inputs, 14 digital input pins, a USB port along with a 5-volt DC power jack and an ICSP header. A reset button also being provided for emergency purpose. All the modules required to support the microcontroller are present in it. It is a programmable microcontroller that is affordable, adaptable, and simple to use. Here we have used Arduino Uno R3 as the main microcontroller board. This is responsible for checking the availability of slots in the parking system and determining the opening and closing of the entry and exit gates of the parking lot.[4]

NODEMCU ESP8266 Wifi Module- Open-source Lua-based NodeMCU firmware is designed specifically for Internet of Things-based applications. NodeMCU can operate at a very minimal DC voltage of 3.3 volts but its input voltage varies from 7volts to 12 volts DC. In our line of work, this module transfers signals to the app to turn on the LEDs in parking spaces.[5]

IR Sensors - It operates at 5 VDC and is based on the optics principle. It also offers to shield against EMI and a low supply current. Its range reaches 20 cm. They are used for sensing the cars when they occupy the spots that result in the LEDs being turned on.[6]

Servo Motors - A servo motor is a kind of motor that has extremely precise rotational capabilities. This type of motor typically has a control circuit that gives feedback on the motor shaft's present location. This feedback enables the servo motors to rotate very precisely. In our work, we used this at the gates to open or close only after checking free spaces at parking slots.[7]

#### 5. CIRCUIT DIAGRAM

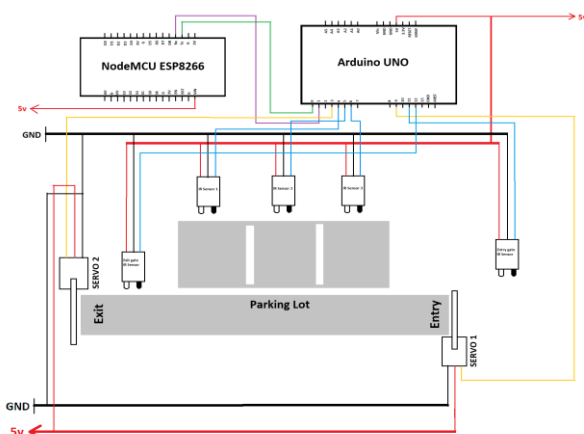

Fig. 1. Circuit diagram of our system

#### 6. MODEL LAYOUT

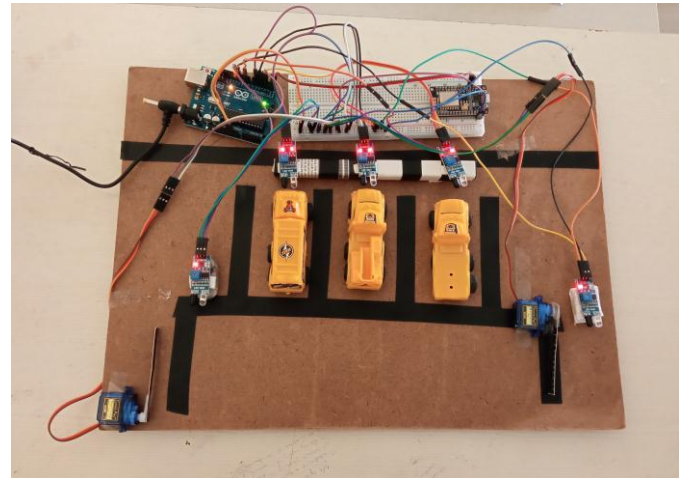

Fig. 2. Model layout of our system

#### 7. BLOCK DIAGRAM

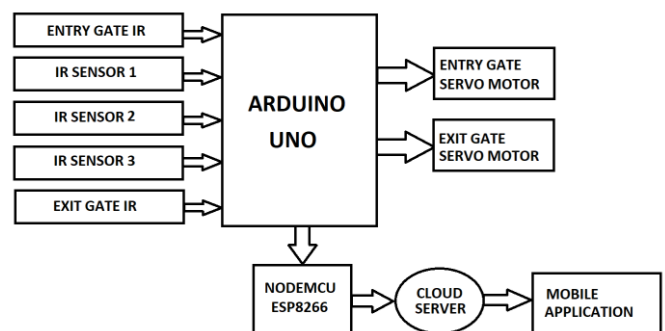

Fig. 3. Block diagram of our system

#### 8. METHODOLOGY

In this study, we have developed a system that consists of a mobile application through which we can check the availability of slots in parking lots. A servo motor is present along with an IR Sensor at the entry and exit gate. Various scenarios exist when a car wants to park. The first case is when a car arrives at the entrance then the sensor transmits the signal to the Arduino UNO for checking whether any slot is available or not. If a vacant space is traced then the servo motor opens the gate and the car occupies the space. Then the IR Sensor associated with that particular slot senses and sends the signal to Arduino, which sends the signal to the NodeMCU ESP8266 module. It then transfers the signal to the mobile application for which the LEDs at the occupied slot turn on and in the app, we can monitor that the slot is booked.

In the next case when the car leaves the slot the sensor present in it turns the LED off. The motor at the exit gate opens which in turn imparts the signal to the WIFI module to the mobile app that in turn shows the spot is empty after the

car leaves. This system is efficient, low cost, and eases people who will be able to check spots in their app which reduces traffic jams and chaos.

### 9. FINAL RESULT

Case 1 – When a slot is available in parking lot, then the entry gate opens for the waiting car.

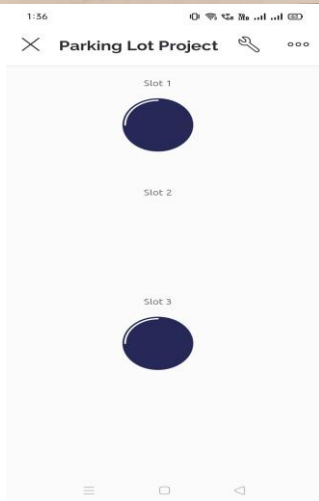
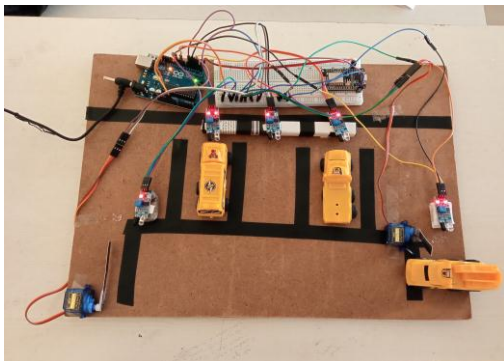

Fig. 4.1. Result of case 1

Case 2 – When all the slots are reserved, then the entry gate will not open for other cars.

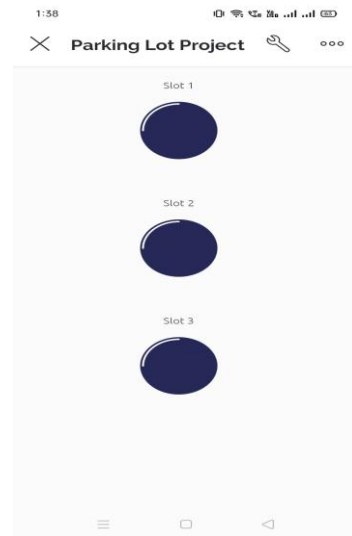
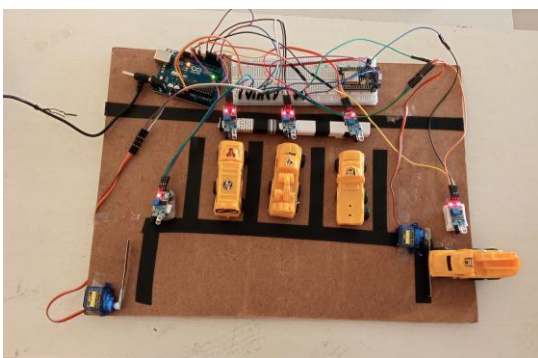

Fig. 4.2. Result of case 2

Case 3 – When a car leaves parking lot through exit gate, then slot will be available for other cars and the entry gate will open for incoming cars.

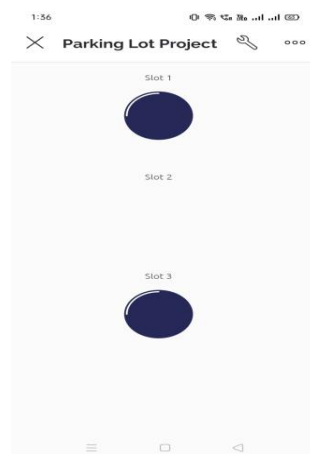
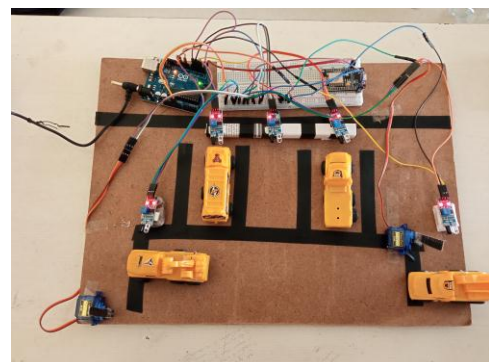

Fig. 4.3. Result of case 3

## 10. CONCLUSION AND FUTURE SCOPE

In our work, we attempted to reduce the driver's effort in looking for a free parking lot. Hence, it saves time and lessens traffic congestion. As a consequence, a driver needs to travel less distance and can lower fuel consumption which helps in controlling pollution.

In near future, we have planned to incorporate navigation-based searching along with online pre-booking of parking slots.

## 11. REFERENCES

- [1] Aashish Joshi, Arni Tharakaram Hariram, K M Vishall Somaiya, Mubashir Hussain, "Smart Car Parking System", International Journal of Engineering Research & Technology (IJERT), ISSN:2278-0181, Vol. 9 Issue 09, September-2020.
- [2] Brundaban Mishra, Arjun Verma, Akshit Gupta, Mrs. Swati Singh, "Smart Parking System", International Research Journal of Engineering and Technology (IRJET), e-ISSN: 2395-0056, p-ISSN: 2395-0072, Volume: 05 Issue: 04, April-2018.
- [3] Smita Awagan, Supiya Borkar, Payal Mandavkar, Seerat Chowdhary, Prof. Deepa Bhattacharya, "Smart Car Parking System", International Research Journal of Engineering and Technology (IRJET), e-ISSN: 2395-0056, p-ISSN: 2395-0072, Volume: 07 Issue: 05, May-2020.
- [4] Arduino Uno datasheet
- [5] NODEMCU ESP8266 Wifi Module datasheet
- [6] IR Sensor datasheet
- [7] Servo Motor datasheet