

Design and Simulation of Multipurpose Automator

D Karibasavaraja¹, Prathiksha CS², Preethi S³, Priyanka R⁴, Vidisha HV⁵

¹ Assistant Professor, Dept. of I&P Engineering, JSSTU, SJCE, Mysore

^{2,3,4,5} Under Graduate, Dept. of I&P Engineering, JSSTU, SJCE, Mysore

Abstract - The world entering the new age equipped with the modern culture and Technological improvements from the atomic level to the space exploring the instruments has never stopped improving. People who push manual wheelchair/cart face difficulties traveling long distances, up slopes or over uneven terrains. A device which aids in moving the wheelchair/cart could reduce the strain. The primary goal of the project is to fabricate an attachable frame that can be used by physically handicapped to move their wheelchairs on their own, also used to push small loaded carts by labors. The easy attachable and detachable mechanism would be used with simple mechanical linkage that gives the user the freedom to detach and attach the frame with ease. The frame would be run by a single high torque electric motor-powered wheel which enables the Automator to move wheelchairs and carts that in turn is fed by a rechargeable battery, which enables considerably a long-range run. The maneuvering freedom is given to the user and is also equipped with w throttle and brake. This multipurpose Automator is mainly for disabled people who use wheelchair on daily basis. They are prone to shoulder and limb injuries while propelling wheelchairs over long time. The area of usage is extended to the hand carts pushed around by workers in construction sites or farms. In these two cases they can attach Automator to their wheelchair/carts.

Key Words: Automator, Holder, Wheelchair, Handcarts.

1. INTRODUCTION

The world entering the new age equipped with the modern cultures and technology improvements from the atomic level to the space exploring instruments has never stopped improving. Also, main Idea behind the innovation of machines is to reduce the human effort and solve the problems in everyday life, most of which cross parts with the poor and physically disabled. People who push manual wheelchair / cart face difficulties travelling long distances up slopes or over and even terrains. A device which aids in moving the wheelchair/cart could reduce the strain. Among the many issues solutions have been found and implemented to make their lives easier while reducing their dependency on others. While the solutions are available at a cost which is not accessible by everyone.

Wheelchair:

The first user profile wheelchair was designed and built by Stephen farfler in 1665. Made of wood consisted of three wheels similar to today's tricycle was very heavy but played on important part in shaping today's wheelchairs. Used in hospitals to transport patients and by the physical disabled to make their movement easier. From self-propelled to motorized, from wheelchair have come a long way and are light weighted, comfortable and available at different market ends.

Handcarts:

These are manually moved career type frames with wheels. Mainly used by street vendors at construction sites warehouse. These come in different forms 2-wheels, 3-wheels 4-wheels and depending on the need of the job the structure and size varies.

There are 7 billion people leaving on the planet out of which 7% or physically disable 6% of the total daily wage workers work with handcarts in their daily life 12% of world's population or prone to be bone damages, ligament displacements, shoulder injuries each year out of which 4% account of wheelchair users or those who push and cards this reports result in caring a mental barrier for those who are weak to propel wheelchairs and handcarts on their own yet have to no option.

Automator:

Automator is any device who's working element is a motor powered by a battery used to eliminate human efforts in the process the term was coined by L. Ferdinand in 1952 When she develops a custom-made trolley attached to a scooter which should further be used to carry vegetables for his farm to house. The idea was further used by farmers in England who altered the design has per their needs for the popularised into daily use by meat and vegetable seller mostly with ice cream vendors.

A device which aids in moving the wheel cart would reduce the strain the primary goal of the project is to fabricate and attachable frame that can be used by physically handicapped to move their wheelchairs on their own also used to push small loaded carts by labourers the easy attachable and the detachable mechanism would be

used with simple mechanical linkage that gives the user the freedom to or attach and attach the frame with ease.

1.1 Literature Survey:

These papers help detailed information related to calculation like Total tractive effort, wheel torque, battery runtime and distance travelled by the vehicle. It gives idea related to motors which are suitable for electric vehicle. It also gives main difference between lithium-ion and lead-acid, which one is more efficient, high durability.

1. Pappuri Hazarathaiyah 1 Assistant Professor Y. Ashok Kumar Reddy Associate Professor "Design and Fabrication of Hybrid Electric Bike". The paper consists of detailed calculation for the tractive force and wheel torque required.
2. "Analysis of different types of motors for the use in electric vehicles" Sasha the induction motor is the best choice for high power electric vehicle applications. The brushless DC motor is a viable choice to be used in low power electric vehicles such as electric auto-rickshaws and two - wheelers.
3. Comparison of Burnetel this study types for electric Vehicles Ichodean1, B Vargal, N Burnetel, this study presents the autonomy of an Electric Vehicle that utilizes four different types of batteries: Lithium Ion(Li-Ion), molten salt(Na-NiCl₂), Nickel Metal Hybride (Ni-MH) and Lithium Sulpur(Li-S).
4. "Automotive Chassis1 Design Material selection for Road and Race Vehicles "Shiva Prasad U, Athota Rathan Babu. This work is oriented towards the material usage in the road and race vehicle chassis in the automotive industry.
5. Yu Munkata et al made an external motorised system for driving a manual wheelchair with an active caster. In spite of a single drive wheel, 2DOF of the wheelchair is achieved with an active caster drive system that is controlled independently without any constraint.
6. California polytechnic State University, A Luis Obispo and Hochsdule Munchen, school of applied sciences jointly designed and built a working portable and detachable hand powered rear wheel drive wheelchair. They took local resident points over previous generation wheelchairs and designed a new electrically powered wheelchair.
7. Dafne Zulema Morgado Ramirez and Catherine Holloway studied both physical and nonphysical

barriers that a wheelchair user faces while operating it. On interviewing many wheelchair users, they found that those who propelled wheelchairs by themselves are prone to upper limb injuries resulting in upper limb joint pain and reducing muscular strength.

8. Girish Khope, Rajesh Pandlik Mali, Onkar Pramod worked on the electrical attached of wheelchair for handicapped person.
9. Agarwal N, Ricket, Sarthak Uniyal made semi-automatic wheelchair automator.
10. Winai chanpeng, Prasert Hachanont worked on design on efficient in wheel motor electric vehicles.
11. Ursina Arnet, Stefan Van Drangelon worked on the shoulder load during hand cycling at different incline and speed conditions.
12. Richard Simpson, Edmund lopresti Steve hayashi worked on prototype power assist wheelchair than provides for obstacle detection and avoidance for those with visual implements.

1.2 Problem Statement:

Most of the physically disabled make use of wheelchair in their daily lives which helps them to move around. These have to be propelled with their own strength using their hands or sometimes with the assist of people around them. Majority of the times they require a helper. Exposure to continuous stresses and movements as time passes by the bones grow weaker making them prone to limb injuries and other problems. Also, the wheelchairs restrict the user's movement to a short distance usually as it requires manual work to be performed.

Every time we go around there is always a sight of a handcart usage whichever the reason maybe. These help in transporting goods at a platform or bricks at a construction site or any kind of luggage on the streets or materials in warehouse. It requires a certain amount of energy to move the cart which may be difficult to handle at situations when the work load is heavy and needs to be performed continuously.

The efficiency of the worker drops gradually resulting in the delay of work that is to be carried out. Also, most of the workers involved in these actions face joint pain and limb injuries caused in the process of working with the cart. While both wheelchairs and hand carts move on human muscle strength of the user, what if there was a device that could eliminate the human work done on them which could be used in case of both wheelchair and hand cart user.! This is where our project comes into action.

2. Motivation for the proposed work:

We see a lot of people struggling to move around in their wheelchairs as some lack the strength to propel themselves around on their own. Also, those workers inducing lot of work to move handcarts either on streets or farms or another place they required a compact device that could reduce the work on their shoulders making the job easier.

Overall Aim:

To eliminate the work done by the user in moving the wheelchair and handcart thus making the job easier.

Specific Objectives:

1. To design an Automator and fixture that can be attached to wheelchairs, 3-wheel carts used in construction sites, 4-wheel carts used in warehouses or farms.
2. To simulate the automator attached to wheelchair and handcart through a fixture.

3. Present Work:

The designed Automator is model and attached to a wheelchair model in the Figure 1. The assembly shows the position of attachment of the automated to the wheel chair which can be adjusted manually depending upon the user requirements.

Conceptual Design:

We obtained the real-world measurements from the wheelchair and manual carts so as to get required dimensions for the Automator sizing. The drawing from the specification development is inserted with design dimensions. The combination of both yields the model, which on further improvements upon certain areas (linkages, manufacturing process, and analysis) is ready for modelling. They would undergo FEA tests to locate weak points and would be further optimized based on the results from the tests.

A low-end wheelchair used commonly in hospitals was referred for the dimensions which can be seen in the figure 1. The figure depicts a wheelchair where a person can sit on it comfortably with both hands and legs in easy position. The measurements were taken keeping in mind the easiness of the user to hold the handle and is shown in figure 1.

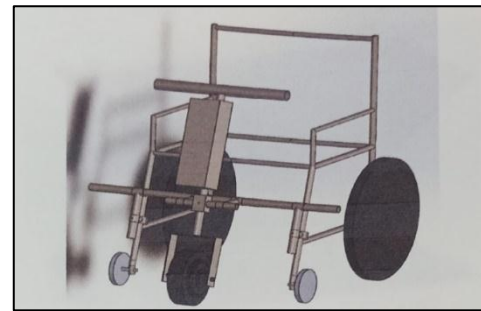

Fig 1: Proposed Wheel Chair

4. METHODOLOGY

Primary Calculations:

This part deals with the basic calculations associated with the primary operations and components that would be detail in the model thus making it one of the important steps that decides the maximum of the project. It includes topics related to motor and battery performance, loads and moments acting on frame, The factor of safety and external factors that influence Operation.

Motor calculation:

1. Diameter=8inches=0.2m
2. Voltage=24v
3. Power=350w
4. Radius of wheel=0.1m

Assumed values:

1. Acceleration=0.5m/s²
2. Desired top speed=5.5m/s
3. Total mass of vehicle(M)=130kg

Step 1: To find Gross Vehicle Weight

$$GVW = M * 9.81$$

$$= 130 * 9.81$$

$$GVW = 1275.3N$$

Step 2: To find total tractive effort requirement for the vehicle

$$TTE = RR + GR + FA$$

Where,

TTE=Total Tractive Effort(N)

RR=Rolling Resistance(N)

GR=Force required to climb a grade(N)

FA=Force required to final acceleration to final velocity(N)

The components of this equation will be determined in the steps.

Rolling Resistance (RR)

Where,

GVW=Gross Vehicle Weight

CRR=Co-efficient of Rolling Resistance

For good concrete,

$$RR=1275.3*0.01=12.75N$$

Table 1: Rolling Resistance

Contact Surface	CRR
Concrete (Good/fair/poor)	0.010/0.015/0.020
Asphalt (Good/fair/poor)	0.012/0.017/0.022
Wood (Dry/Dusty/Wet)	0.010/0.005/0.001
Surface Snow (2 inch/4 inch)	0.025/0.037
Dirt (Smooth/Sandy)	0.025/0.037
Mud (Firm/Medium/Soft)	0.037/0.090/0.0150
Grass (Firm/Soft)	0.055/0.075
Sand (Firm/Dune/Soft)	0.060/0.150/0.300

Grade Resistance (GR): $GVW*\sin(\theta)$

For plain surface $\theta=0$

GR=0

Acceleration Force (AF)

$FA=M*a$

$FA=130*0.5$

$FA=65N.$

Total Tractive Effort (TTE)= $RR+GR+FA$

$TTE=12.75+0+65$

$TTE=77.75N.$

Step 3: To find the wheel torque

Wheel Torque (TW)

$TW=TTE*RW*RF$

$TW=77.75*0.1*1.1$

$TW=8.55N/m$

The required Wheel Torque is 8.55 N/m.

Battery Calculation:

1. Voltage=24v
2. Current=20Amp
3. Wheel Torque=8.55N-m

Assumed value:

1. Displacement=1000

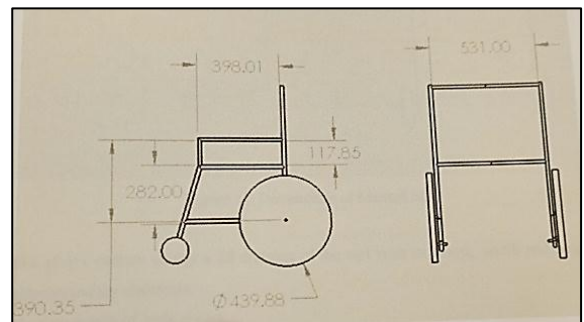

Fig2: Dimension of Wheelchair

Measurements of Wheelchair

1. Distance between – (Distances are in mm)
2. Arm Rest and ground = 610.29
3. Hip Rest and Arm Rest = 117
4. Hip Rest and Ground = 501.94
5. Shoulder Rest and Arm Rest Front = 398.01
6. Hip Rest and lowest Fixture Point = 288
7. The Holders = 531.00

Parts:

1. Automator chassis

1. Handle: used by user to manoeuvre, accelerator, break is attached to it.
2. Perpendicular extrusion connect handle to wheel. Carries the battery box and attachment fixture.
3. Fixture body: two cylindrical extrusions emerging from a hollow cuboid that holds a ball bearing through which the perpendicular passes.
4. Wheel plate: holds the wheel in the position

5. Wheel: holds the hub motor.
6. Battery box: holds the battery and is attached to the perpendicular extrusion.

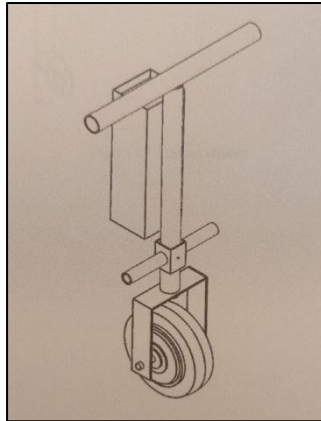

Fig3: Automator Chassis

Fixture frame:

1. Holder 1: connects the automated to the with adjustment bar.
2. Holder 2: connects the holder 3 to the width adjustment bar.
3. Holder 3: holds the wheelchair / cart
4. Width adjustment bar : horizontal bar about which holder one and holder to can be moved and rotate to adjust the user needs

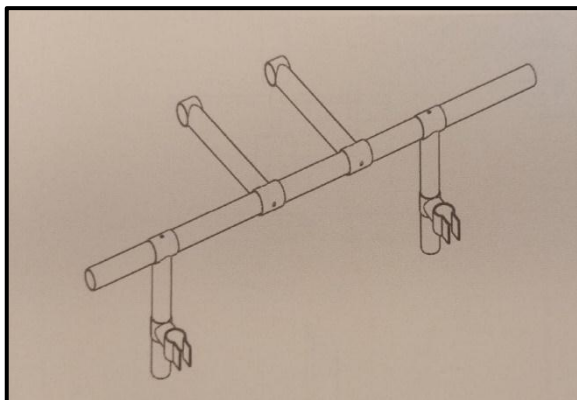

Fig: 5 Fixture Chassis

5. COMPONENTS AND MATERIAL SELECTION

The Calculation done in the above step are used to create a shortlist of component that would be Finalized further depending upon the cost and reliability parameters to confirm they sum up as per the budget plan. The material

selection is also based on the calculations performed in the above process. The materials with desirable properties based on calculations are shortlisted and are check up on their uses and performance in industrial practices.

Battery: 24 volts, 20Ah lithium-ion battery is required.

Materials: Steel 4130 frame.

(Tensile strength: 560 MPa, Yield Strength:460 MPa, Modulus of elasticity: 205GPa)

2. Wheels: 8 inches 24V, 350W 1 Electric Wheel.
3. Handles: Steel 4130 2 handles.

Electric wheel

Wheel hub motor which is also called wheel motor it is an electric motor coupled to the wheels of a vehicle. Nowadays wheel hub motor is best suitable for electric vehicle.



Fig4: Electric Wheelchair

Battery:

A lithium-ion battery is a type of rechargeable battery. Medium ion batteries are lighter and smaller than lead acid batteries. Nowadays medium ion batteries are used in electric vehicle

Working:

While the battery is discharging and providing an electric current the ion oat releases lithium ion to the cathode generating a flow of electrons from one side to the other. When plugging in the device the opposite happens. Lithium ions released by the cathode and received by the anode.

Advantages:

1. Highly dense in volume
2. High discharge rates
3. High charge rates
4. Compact in size



Fig6: Lithium-ion Battery

Braking System:

A drum brake is a brake that uses friction caused by a set of shoes or pads that press outward against a rotating cylindrical shaped part called a drum. The term drum brake usually means a break in which shoes press on the inner surface of the drum. when shoes press on the outside of the drum it is usually called a clasp break. Where the drum is pinched between two shoes similar to a conventional disc brake it is sometimes called A pinch drum break though such breaks are relatively rare. A related type called a band-break uses of flexible belt or band wrapping around the outside of a drum

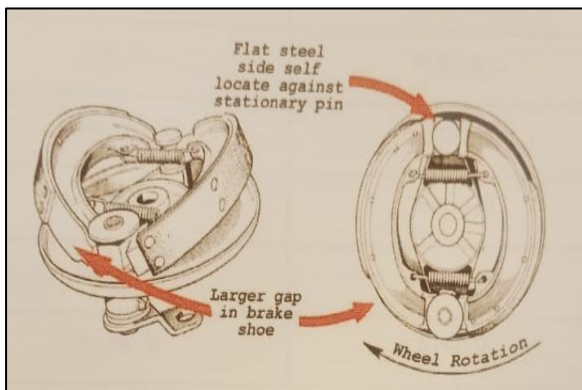

Fig7: Drum Brake System.



Fig8: Brake Lever

5. CONCLUSION

1. The developed model can be used for loads of 100kg and under. It runs with the help of an electric brushless motor of torque 20Nm which in turn is powered by a lithium-ion battery of 24V and 20Ah charge.
2. The design weight of the model is estimated to 11kg approximately where the chassis made up of 4130 steels with the fixture weighs around 4kg, the wheel assembly takes up 4kg and lithium-ion battery is 3kg.
3. The detached custom designed fixture is the important part of our project, as it allows the Automator to be attached to wheelchair, 3- and 4-wheel carts.
4. Calculations are performed for a load of 130kg considering flat ground the Automator is able to travel 9.26km at a velocity of 1m/s or with a run time of 2.57 hours.
5. This is also cheaper than the commercial wheelchair attached model but with less budget and more range.
6. The device is attached to the wheelchair /cart with the help of fixture. A clamp structure is used at the attachment side of the fixture whose ends are tightened with the help of screws.
7. To arrest the rotation of the holders in the fixture assembly screws are used to lock the holders at a particular angle once the attachment is done. The device is maneuvered with the help of a handle to which an accelerator and brake is attached.
8. Offers an operational velocity of 0-20kmph to the user. The design is modelled, analyzed for deformations and simulated.

References:

1. Pappuri Hazarathaiyah Y, Ashok Kumar Reddy, Vijaya Bhaskara Reddy, Sreenivaulu "Design and Fabrication of Hybrid Electric Bike", International Journal of Applied Engineering Research ISSN 0973-4562 Volume 14, Number 4(2019) pp. 930-935.
2. Sessa Gopal S "analysis of Different Types of Motors for the Use in electric Vehicles". International Research Journal of Engineering and Technology Volume: 07 Issue: 06| June 2020.

3. Clodeanl, B Vargal, N burnetel, D Cimerdeanl and B Jurchig “Comparson of Different Battery Types for Electric Vehicles “, IOP Conference Series: Material Science and engineering. Volume 252, CAR2017 International Congress of Automotive and Transport Engineering – Mobility Engineering and Environment 8-10 November 2017.
4. Shiva Prasad U, Athota Rathan Babu, Bandu Sairaju, Sai Krishna Amiri Shetty, Deepak D “Automotive Chassis Design Material Selection for Road and Race Vehicles”, Journal of Mechanical Engineering Research and developments Vol. 43, No. 3, pp. 274-282 Published Year 2020.
5. Sruthi ramachandran, N, Vijay Singh, “Motorized Hand Bike for Manual Wheelchair”. International Journal of Innovative Research in Science.

BIOGRAPHIES



Karibasavaraja D
Assistant Professor



Prathiksha CS
Under Graduate



Preethi S
Under Graduate



Priyanka R
Under Graduate



Vidisha HV
Under Graduate