

DESIGN & FABRICATION OF MULTI PURPOSE WHEELCHAIR

T. Kumar Raju¹, M. Ganesh², R. Deepak Gill³, K. Sai Teja⁴, N V V S Reddy⁵

¹Assistant professor, ^{2,3,4,5}UG Students,

^{1,2,3,4,5} Department of Mechanical Engineering, VSM College of Engineering, Ramachandrapuram, Andhra Pradesh, India.

ABSTRACT

The purpose of this project is to manufacture the multipurpose wheelchair in low cost which promotes mobility and enhance the quality of life for the people who have difficulties in walking. This product makes the users to lift the patient directly from the bed which help to reduce the pressure injuries. Along with the reducing the cost of product, we also aim to minimizing the pressure injuries and fall. Other specialty of the multipurpose wheelchair is, we can use it on indoor as well outdoor. Then after the completion of project we have successfully achieved what we set out to bring in wheelchair. We made a better multipurpose wheel chair with all safety measures, low cost and high quality. It provides a safe transferring of patients from one place to another place. The procedure that is used for transferring patients is very simple and unique.

KEYWORD: Hospital, Patient, wheel chair.

INTRODUCTION

Disabilities have affected thousands of families in the world. As of today 650 million people are suffering from disability. Their disabilities can be empowered and enable them to live a normal and independent life with the help of wheelchair. New and modified wheelchairs can satisfy the need of disable people rather than the old and conventional ones. To help the disabled various design changes have been done. One is by introducing a detachable defecation system to it. It provides ease to the patients and the staffs. Wheelchair mobility opens up opportunities for wheelchair users to study, work, engage in social activities and access services such as healthcare In addition to providing mobility, an appropriate wheelchair benefits the physical health and quality of life of the users by helping in reducing common problems such as pressure sores, progression of deformities and improve respiration and digestion. Wheelchair designs vary to enable users to safely and effectively use their wheelchair in the environment in which they live and work. A wheelchair that is used primarily in rough outdoor environments needs to be robust, more stable and easier to propel over rough ground.

LITERATURE REVIEW

2.1 According to Sumedh J. Suryawanshi, Dr. K. Janardhan Reddy

Different methods like FL, DARE analysis and Pugh concept selection method for converting the needs of the customers into a conceptual product are discussed in detail. The role of feedback from the wheelchair has played an essential role in the development process and helped in developing the product satisfying their needs. This wheelchair developed can easily help the people disabled in legs to transfer themselves to bed without any assistance.

The main criteria considered for this concept is the convertible wheelchair and stretcher. So in order to convert the wheelchair into stretcher, some sort of

mechanism needs to be added. In this concept a sliding tubular frame is attached to the back rest of the wheelchair. A handle is provided in the back rest so that the user can be pulled it easily and can be converted to stretcher easily. So a proper balance should be maintained in the back side because the centre of gravity of human body will be lying in between the seat and back rest portion. A caster wheel support is given so that proper balance will be achieved. A pair of bigger wheels is provided in the middle of the wheelchair, so that more strength will be attained and front caster guides the wheelchair according to the direction. The provision for oxygen cylinder is another demand which has observed during the user study and the drip holder location is provided by the sides of the wheelchair. The hand rest is designed in such a way that, it can be rotated and a removable type so that it will act as a support side for transferring the patients.

DESIGN & FABRICATION

3.1 COMPONENTS SELECTION RAW MATERIALS

S. NO	PARTS	QTY	MATERIAL
1	Frame	1	GI
2	CastorWheels	2	Thermo plastic Rubber
3	Sponge seat	3	sponge
4	Nylon tyre	2	Nylon
5	Rear wheels	2	Iron
6	Levers	2	Mild steel
7	Clamp & Collar	4	Iron
8	Bolt & Nut	10	Steel
9	Star Screws	16	Stainless steel
10	Mild steel base	2	Mild steel
11	Half rounded pipe	3	Iron
12	Hinges	4	Iron

3.3.1 Introduction ToV.0.49.0.0 AUTO CAD 2018

The term **CAD (Computer Aided Design)** applies to a wide range of programs that allowth user to created drawings, plans, and designs electronically. AutoCAD is one such program and it main claim to fame is that it is relatively easy to use, it is very comprehensive in its ability to create 2D andsome 3D drawings, and it is very popular. Seventy percent of the CAD users in the world use AutoCAD.

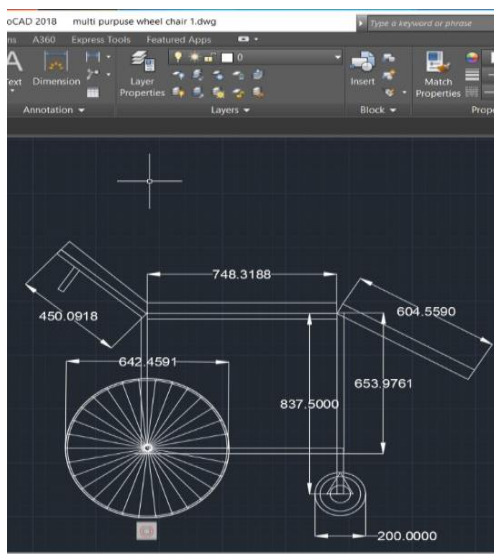

DIMENSIONING IN DRAWINGS:

The dimensions are inserted in the drawing by use of DIM command. There are various types of dimensions used in AutoCAD. Linear dimensions:

Horizontal-this allows horizontaldimensions

Vertical- this allows vertical dimensions Aligned- this allows inclined dimensions Rotated- this allows inclined dimensions

ASSEMBLING PROCESSCUTTING PROCESS

Cutting processes work by causing fracture of the material that is processed. Usually, the portion that is fractured away is in small sized pieces, called chips. Common cutting processes include sawing, shaping (or planning), broaching, drilling, grinding. and milling. Although the actual machines, tools and processes for cutting look very different from each other, the basic mechanism for causing the fracture can be understood by just a simple model called for orthogonal cutting. In all machining processes, the work piece is a shape that can entirely cover the final

DRILLNG PROCESS

Drilled holes are characterized by their sharp edge on the entrance side and the presence of burrs on the exit side (unless they have been removed). Also, the inside of the hole usually has helical feed marks. Drilling may affect the mechanical properties of the work piece by creating low residual stresses around the hole opening and a very thin layer of highly stressed and disturbed material on the newly formed surface.

WELDING PROCESS

Introduction to welding process Introduction Welding is a process in which two or more parts are joined permanently at their touching surfaces by a suitable application of heat and/or pressure. Often a filler material is added to facilitate coalescence. The assembled parts that are joined by welding are called a weldment. Welding is primarily used in metal parts and their alloys. Welding processes are classified into two major groups: 1. Fusion welding: In this process, base metal is melted by means of heat.

GRINDING OPERATION

Grinding practice is a large and diverse area of manufacturing and tool making It I can produce very fine finishes and very accurate dimensions; yet in mass production contextsit can also rough out large volumes of metal quite rapidly. It is usually better suited to the

International Conference on Recent Trends in Engineering & Technology- 2023 (ICRTET-3)
Organised by: VSM College of Engineering, Ramachandrapuram

machining of very hard materials than is "regular" machining (that is, cutting larger chips with cutting tools such as tool bits or milling cutters), and until recent decades it was the only practical way to machine such materials as hardened steels. Compared to "regular" machining, it is usually better suited to taking very shallow cuts, such as reducing a shaft's diameter by half a thousandth of an inch or 12.7 um.

WORKING AND DISCUSSION

As a result of this project, we designed and manufactured a better multipurpose wheelchair for transferring patients from bed to stretcher and vice versa at a cost that is more appropriate in the Indian context. Wheelchair analysis was carried out both theoretically and practically. During the practical examination. The weight of 100 kg was loaded and using a multifunctional wheelchair, I was able to lift myself. The cost of a versatile wheelchair is very low r, which is relatively affordable when compared to other wheel chairs.

ADVANTAGES

- Increase in comfort level of the patient.
- Prevents further damage to patients and the helper while transferring him/he from chair to bed vice-versa.
- Patients with serious injuries need not be moved to aggravate their injuries even more.
- No special training required to operate them.
- Is more efficient than other chairs



Figure 4.1 Output Figure



APPLICATIONS

- It can be used in hospital.
- It can be used in houses.

LIMITATIONS

- The weight is more.
- The cost is a little more

CONCLUSION

This project work has provided us an excellent opportunity and experience, to use our limited knowledge. We gained a lot of practical knowledge regarding, planning, purchasing, assembling and machining while doing this project work. We feel that the project work is a good solution to bridge the gates between the institution and the industries.

We are proud that we have completed the work with the limited time successfully. The fabrication of travelling treadmill bicycle is working with satisfactory conditions. We can able to understand the difficulties in maintaining the tolerances and also the quality. We have done to our ability and skill making maximum use of available facilities.

It is concluded that now a-days in hospitals fullyatomized beds, wheelchairs and stretchers are used for the patient handling purpose. But they are very costly and are not affordable to all the hospitals. The stresses developed during the handling of patient in both, i.e., patient and staffs are same for all the hospital. A new design of

International Conference on Recent Trends in Engineering & Technology- 2023 (ICRTET-3)
Organised by: VSM College of Engineering, Ramachandrapuram

wheelchair cum stretcher for patient handling has been done. Cost of such type of wheelchair cum stretcher will be affordable for all type of hospitals and it will be beneficial for patient handling. The product will thus likely be an efficient mobility aid in hospitals.

FUTURE SCOPE

The versatile wheelchair must be readily available and economical in the country of use, as well as maintainable and long-lasting. This is not always straight forward, as wheelchair users are adverse group with varying needs, as well as environmental and socio economic factors .For many persons with impairments, a multipurpose wheelchair is more than an aid; it is a necessity. A mechanism by which individuals might enjoy their human rights and achieve equal participation and inclusion

REFERENCES

- [1].Yoshikazumori, Norikatsu Sakai, Kaoru Katsumura, Development Of A Wheelchairwith A Lifting Function, Advance In Mechanical Engineering, Volume 2012.
- [2]. William Armstrong, Johan Borg, Marc Krizack, Alida Lindsley, Kylie Mines, Jon Pearlman, Kim Reisinger, Sarah Sheldon, Guidelines On The Provision Of Manual Wheelchairs In Less Resourced Settings, World Health Organization 2008.
- [3]. Sumedh J Suryawanshi, Dr. K. Janardhan Reddy Conceptual Product Development Of Wheelchair For People Disabled In Legs, International Journal Of Research In Mechanical engineering,Volume 1, 2013.
- [4]. Mohan Kumar R, Lohit HS, Manas Ranjan Mishra, Md Basheer Ahammed, Design Of Multipurpose Wheel Chair For Physically Challenged And Elder People,SAS TECH, Volume 11, 2012.
- [5]. Imran Aslam, Scot A Adavis Steven R,Willis Martin, A Review Of Patient Intervention To Reduce Health Care Workers Inquiries, Workplace Health And safety, Volume 63, 2015