

Railway Track Monitoring System Using Arduino Uno with Wi-Fi Module

A.Narayana Murthy¹, Y.Apparao², D.Subhakar³, P.Veera Babu⁴

^{2,3}Associate professors ^{1,4}Assistant professors VSM College of Engineering Ramachandrapuram

Abstract— Trains offer the cheapest and most convenient form of transportation for long-distance and suburban travel. Also, most of the transportation in India is done by road. Accidents are another major concern related to unplanned railways and buses in Indian Railways. About 60 percent of the accidents occurred on railways and due to cracks in the railways caused the loss of precious lives and property losses. Therefore, it is necessary to think about a new technology that is strong, efficient and stable to detect explosions on the railway and object detection. This function provides a unique train track and object detection system. This project integrates railway information using IOT and is a powerful way to combine the use of GPS tracking system and WIFI system to send notifications and set local conditions. Arduino and LoRa are used to control and coordinate the functions of these devices. This project prevents train derailment by detecting cracks in the railway track using internet technology

Index Terms— IR Sensors, LoRa, GPS, GSM, Arduino UNO, Ultrasonic Sensors, WIFI module,

1 INTRODUCTION

India is the fourth largest railway country in the world after USA, Russia and China. Indian Railways is pursuing growth to meet the travel needs of the population. The railways run the length and breadth of the country and are known to carry more than 30 million cars and 2.8 million tons of freight every day. However in terms of reliability and safety margins, we are far from real world standards. Although the railways are running fast in India but due to the lack of proper safety measures, there have been many train accidents resulting in loss of property and human lives. One of the main causes of this type of train accident according to statistics is the crack seen on the rail shown in the picture, which can be caused by negligence or improper equipment. zero. Analyzing a song by hand is a difficult task.



2 EXISTING SYSTEM

To solve this problem, many techniques have been applied, including image analysis, non-destructive testing (NDT) techniques such as acoustic smoke, magnetic field methods, radiography, etc. thermal field type, types of fiber optic sensor - different, using LDR and so on. A detection system is described that includes a laser source, a control CCD camera and a control system. These systems may be inaccurate or difficult to detect cracks.

2.1 PROPOSED SYSTEM

The main objective of the proposed project is to improve the low cost of rail accidents by using ultrasonic sensors and infrared sensors that send location data to authorized operators.

3 BLOCK DIAGRAM

3.1 BLOCK DIAGRAM EXPLANATION

In this project, we use two Arduino Uno, an IR sensor, and an Ultrasonic sensor used to detect cracks and identify problems if a crack is found on the rail, that is, the system informs the pilot of the aircraft.

TRANSMITTER SECTION

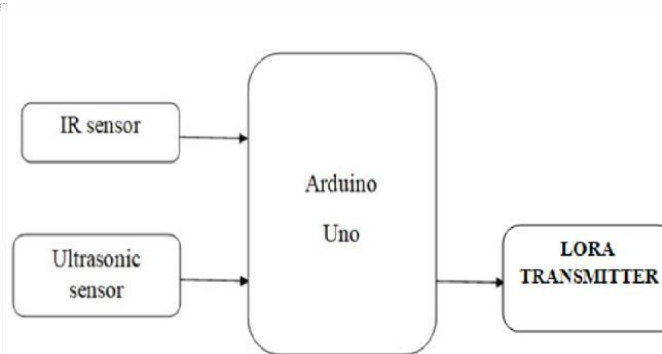

RECEIVER SECTION

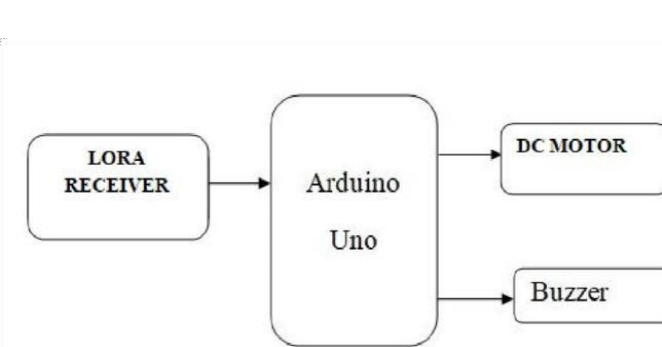

4. HARDWARE COMPONENTS

4.1 ARDUINO



Arduino is a software company, project, and user community that designs and manufactures computer open-source hardware ,open- source software, and microcontroller-based kits for building digital devices and interactive objects that can sense and control physical devices. The project is based on microcontroller board designs, produced by several vendors, using various microcontrollers

These systems provide sets of digital and analog I/O pins that can interface to various expansion boards (termed shields) and other circuits. The boards feature

serial communication interfaces, including Universal Serial Bus (USB) on some models, for loading programs from personal computers. For programming the microcontrollers, the Arduino project provides an integrated development environment(IDE) based on a programming language named Processing, which also supports the languages C and C++.

The first Arduino was introduced in 2005, aiming to provide a low cost, easy way for novices and professionals to create devices that interact with their environment using sensors and actuators. Common examples of such devices intended for beginner hobbyists include simple robots, thermostats, and motion detectors.

Arduino is an open-source electronics platform based on easy-to-use hardware and software. Arduino are able to read inputs - light on a sensor, a finger on a button, or a Twitter message - and turn it into an output - activating a motor, turning on an LED, publishing something online. You can tell your board what to do by sending a set of instructions to the microcontroller on the board.

4.2 ULTRASONIC SENSOR

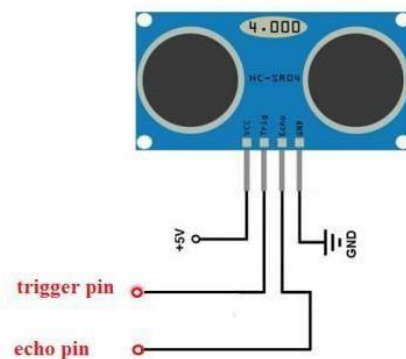

There is provided an ultrasonic diagnostic system in which an ultrasonic probe is detachably connected thereto, and ultrasonic waves are transmitted from the ultrasonic probe into the subject to obtain received signals through receiving the ultrasonic waves reflected within the subject, thereby displaying for a diagnosis an image carrying information based on the received signals, and is also provided an ultrasonic module including a processing circuit for the received signals, the ultrasonic module being used in the ultrasonic diagnostic system.

The Ultrasonic Sensor sends out a high-frequency sound pulse and then times how long it takes for the echo of the sound to reflect back. The sensor has 2 openings on its front. One opening transmits ultrasonic waves, (like a tiny speaker), the other receives them, (like a tiny-microphone). The ultrasonic module is connected through a general-purpose interface to a computer system. An ultrasonic

module, which has, as a main element, an analog unit for performing an analog signal processing, is connected to another computer system.

4.3 IR SENSOR

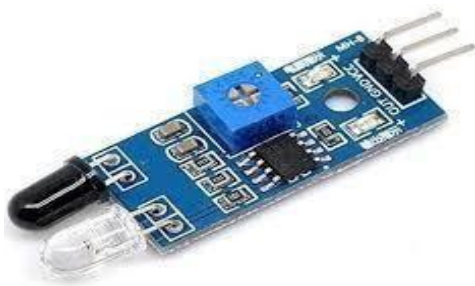

An IR transmitter and receiver can be obtained for a small price. They look like LED. To distinguish between the transmitter and the receiver, the transmitter always goes to bright light regardless of the color of the carrier. In addition to this, there is a receiver that is used to receive a specific IR frequency, 38kHz. For your information, 38kHz IR is often used in remote control. The IR transmitter will emit infrared when activated. You can add an IR emitter like an LED with a current limiter. A current limiting resistor is used to prevent too much current from flowing through the transmitter and blowing it up. I am using a 330 ohms resistor for the IR transmitter.

4.4 DC MOTOR



DC motors are classified into different types. The machine consists of a rotor and a fixed field stator. An attractive field is usually applied using permanent magnets or air. Most DC motors are usually used at high speed and low torque. Movement and control are the various components used to create and maintain movement. Areas of this class include guides and bushings, bearings and motors, control and steering, control units, encoders and sensors, integrated control, limit switches, linear actuators, linear and rotary components, linear configuration, motor detection (AC and DC. machines), starting position detection, pneumatics and pneumatic components, configuration operating procedures, slides and accessories, power steering (engine), seals, slip rings, solenoids, springs.

4.5 GPS



GPS is a system of 30+ satellites that orbit the earth. We know where they are because they always send messages. The GPS receiver in your phone listens for these signals. Once the receiver calculates the distance from four or more GPS satellites, it can determine where you are. The operation/performance of the Global Positioning System is based on the principle of 'trilateration'. Position is determined from remote sensing to satellite. Apart from the number, the four satellites are used to determine the position of the receiver on the ground.

5. SOFTWARE COMPONENTS

5.1 ARDUINO IDE

The Arduino Integrated Development Environment - or Arduino Software (IDE) - contains a text editor for writing code, a message area, a text console, a toolbar with buttons for common functions and a series of menus. It connects to the Arduino and Genuino hardware to upload programs and communicate with them.

6. RESULT

PROJECT SETUP

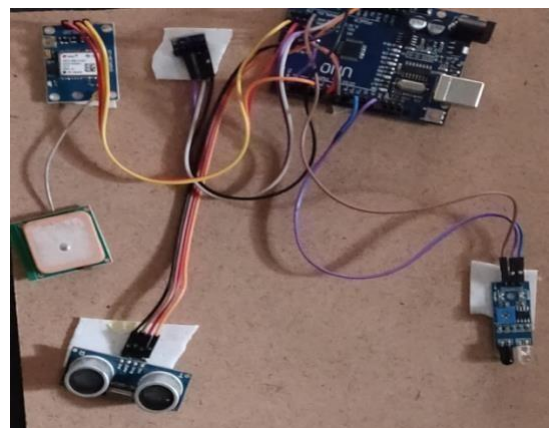

Fig: - Transmitter section

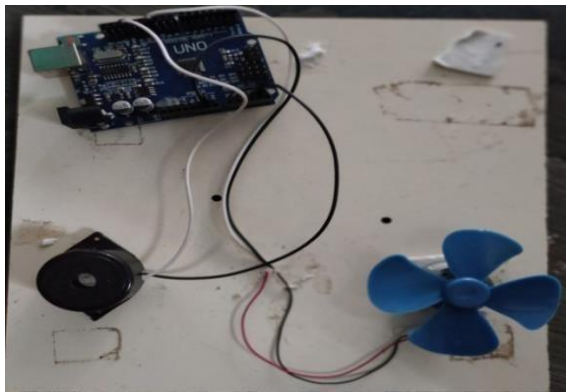

Fig: - Receiver section

7. CONCLUSION

The proposed system can be used to accurately detect cracks and send them directly to the fault location in less time in Interval Determination. The advantages of the proposed system are that it is silent, the output is very good and the cost is very low. This system can be used day or night. Solar panel can be connected to power the system in place of rechargeable battery International Used for the purpose which would make use of renewable energysources.

8. REFERENCES

1. V.Reddy, "Deployment of an integrated model for assessment of operational risk in railway track", Master Thesis, Queensland University of Technology School of Engineering Systems, 2007.
2. C. Esveld, "Modern railway Track". Second Edition, MRT Productions. 2001
3. D.Hesse "Rail inspection using ultrasonic surface waves" Thesis ,Imperial College of London,2007
4. C. Campos-Castellanos, Y.Gharaibeh, P. Mudge *, V. Kappatos, "The application of long range ultrasonic testing (LRUT) For examination of hard to access areas on railway tracks". IEEE Railway Condition Monitoring and Non-Destructive Testing (RCM 2011) Nov 2011.
5. M. Singh, S.Singh1, J. Jaiswal, J. Hempshall "Autonomus rail track inspection using vision based system" .IEEE International Conference on Computational Intelligence for Homeland Security and Personal Safety .October 2006. pp 56-59
6. S.Zheng, X.An, X.Chai, L. Li "Railway track gauge inspection method based on computer vision" IEEE International Conference on Mechatronics and Automation, 2012. pp 1292-1296
7. W. Al-Nuaimy , A. Eriksen and J. Gasgoyne " Train- mounted gpr for high-speed rail trackbed inspection" Tenth International Conference on Ground Penetrating Radal; 21 -24 June, 2004
8. A.Vanimiredd, D.A.Kumari "Automatic broken track detection using LED-LDR assembly" Journal of Engineering Trends and Technology (IJETT) - Volume4 Issue7- July 2013
9. Hayre, Harbhajan S., "Automatic Railroad Track Inspection," Industry Applications, IEEE Transactions on , vol.IA-10, no.3, pp.380,384, May 1974
10. Z. Sam Daliri1, S. Shamshirband , M.A. Besheli " Railway security through the use of wireless sensor networks based on fuzzy logic". International Journal of the Physical SciencesVol.6(3), pp. 448-458, 4 February, 2011
11. S. Ramesh, S. Gobinathan "Railway faults tolerance techniques using wireless sensor networks". IJECT Vol. 3, Issue 1, Jan. - March 2012. [12] A. Z Lorestani ,S. A Mousavi, R. Ebadaty, "Monitoring RailTraffic Using Wireless Sensor Network (WSN)" IJCSET ,June 2012, Vol 2, Issue 6,1280-1282